

MICRO-HIGHROLLER

1/36-SCALE ELECTRIC READY-TO-RUN LIFTED TRUCK



Operations Guide

Introduction

Thank you for choosing the Micro-HIGHroller. This guide contains the basic instructions for operating your new Micro-HIGHroller. While the Micro-HIGHroller is great for first-time RC drivers, it does require some mechanical experience and parental supervision for drivers under 14 years of age. It is critical that you read all of the instructions and all accompanying printed material in order to operate your model correctly and avoid unnecessary damage. Please take a moment to look them over before running your model.

DO NOT RUN YOUR MICRO-HIGHroller ON PLUSH CARPET, GRASS OR SAND.

Warning

Although the best materials and components are used, and due to the size of this model, using anything other than genuine Losi replacement and performance parts specifically designed for the Losi® Micro-HIGHroller could cause damage.

CONNECT - REGISTER - WIN

Register your product online so we can notify you about the latest option parts, product updates, tech tips, service bulletins and more. Visit WWW.LOSI.COM and follow the Product Registration link to stay connected.

For registering your Losi Product you will be automatically entered for a chance to win the Losi Pick Your Prize Sweepstakes. The winner will be allowed to select a total prize package of \$1,000 (retail value) based on their preference

WWW.LOSI.COM

© 2009 Losi, A Division of Horizon Hobby Inc.

GETTING STARTED

1. Plug the AC charger into the proper wall receptacle (110V - US version). Plug the battery pack into the charger and let it charge for 1 hour for the first time. After running, or when the Micro-HIGHroller slows noticeably, recharge the battery pack for 2-3 hours for a full charge.

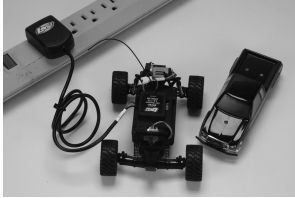

2. Your Losi Micro-HIGHroller includes eight (8) AA batteries for your transmitter. Remove the transmitter battery cover by sliding the cover from left to right. Install the eight (8) AA batteries into the battery holder. Pay close attention to the correct direction of the positive (+) and negative (-) ends as marked in the tray. Once all 8 batteries have been installed, reinstall the battery cover by sliding it on from right to left.



3. Plug in the battery lead into the speed controller lead and replace the body. Secure the body with the included body clips.

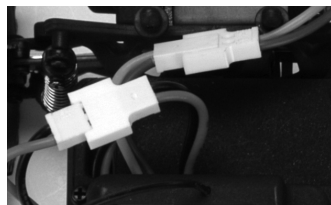

4. ALWAYS turn on the transmitter first by sliding the switch "ON". The small red and green lights above the switch should both light up. If not, please check for low or incorrectly installed batteries.

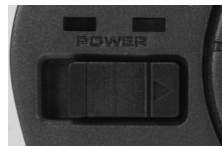

5. Once the transmitter has been turned on, turn on the Losi Micro-HIGHroller by sliding the switch to the "On" position (located on the bottom of the chassis). If the rear wheels turn, adjust the "TH. Trim" knob located to the lower right of the steering wheel until they stop, to go forward pull the trigger back. If you should need reverse, wait for the model to stop then push the trigger forward. When going forward the model should move in a straight line. If not, adjust the "ST.Trim" so that it tracks in a straight line without having to turn the steering wheel. After you are finished running, turn the Losi Micro-HIGHroller off FIRST by sliding the switch to the "OFF" position. After the model has been turned off, turn off the transmitter by sliding the switch to the "OFF" position.

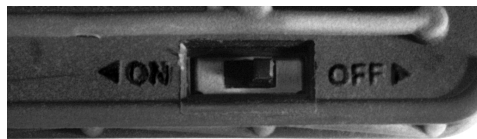

Safety Precautions

Age Recommendation: 14 years or over. This is not a toy. This product is not intended for use by children without direct adult supervision. This is a sophisticated radio controlled model that must be operated with caution and common sense. Failure to operate your Micro-HIGHroller in a safe and responsible manner could result in damage to the model and property. The Micro-HIGHroller is not intended for use by children without direct adult supervision. Losi® and Horizon Hobby, Inc. shall not be liable for any loss or damages, whether direct, indirect, special, incidental, or consequential, arising from the use, misuse, or abuse of this product or any product required to operate it.

- This model is controlled by a radio signal that is subject to interference from many sources outside your control. This interference can cause momentary loss of control so it is advisable to always keep a safety margin in all directions to avoid collisions.
- Always operate your model in an open area away from cars, traffic and people.
- Never run out into the street for any reason.
- Never run your Micro-HIGHroller with low transmitter batteries.
- Carefully follow the directions and warnings for this and any optional support equipment that you use.
- Keep all chemicals, small parts and anything electrical out of the reach of children.

Tools and Items You Will Find Handy

- Soft bristle brush for cleaning
- Losi® Micro Screwdriver - LOSB1602
- Losi® Nutdriver: 4.5mm - LOSA99160
- Small flat blade screwdriver

Note: Use only Losi® or other high-quality tools. Use of inexpensive tools can cause damage to the small screws and parts used on this type of model.

The Transmitter

Steering Wheel: Controls direction (left/right) of the model.

Throttle Trigger: Controls speed and direction (forward/reverse) of the model.

Antenna: Transmits signal to the model.

On/Off Switch: Turns the power on/off for the transmitter.

Indicator Lights: Green (right) light indicates adequate battery power. Red (left) indicates signal strength.

ST. Trim: Adjusts the "hands off" direction of the model.

TH. Trim: Adjusts the motor speed to stop at neutral.

Steering Rate: Adjusts amount front wheels move when the steering wheel is turned left and right.

ST. REV: Reverses the function of the steering when the wheel is turned left or right.

TH. REV: Reverses the function of the speed control when pulled back or pushed forward.

Bottom Cover: Covers and holds the batteries that power the transmitter.

Transmitter Crystal: Determines frequency/channel you transmit on. The receiver must have a matching frequency/channel to operate

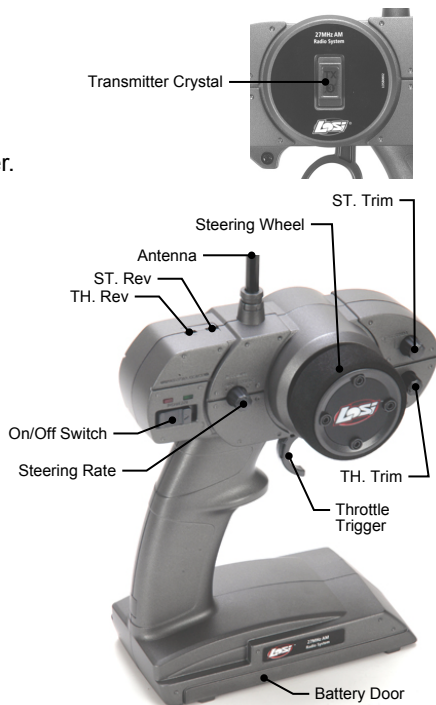

The Receiver/Speed Control

Receiver/Electronic Speed Control: Receives the signal from the transmitter to control the model's power and direction of the motor.

Receiver Crystal: Determines which channel it will receive.

On/Off Switch: Controls power to the receiver.

Antenna Wire: Receives the signal from the transmitter.

Power Plug: Connects battery pack to the receiver/speed control.

Steering Servo: Controls steering movement.

Steering Servo Plug: Receiver connection and power supply.

Motor Plug: Power connection from the speed control.

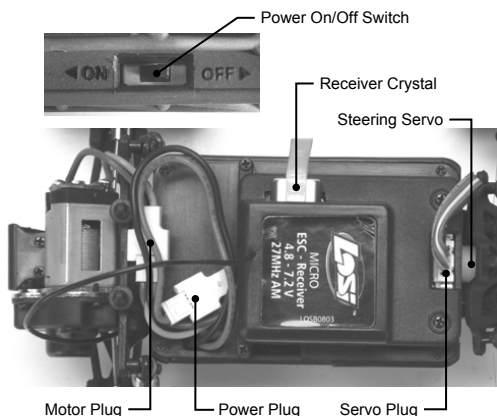

Changing Frequencies/Channels

The Micro radio operates on 27MHz AM and has 6 different frequencies/channels available. Simply put, a frequency is like a TV channel. The transmitter you hold in your hand is like the TV station and the model with the matching crystal is like your TV tuned exclusively to the channel of the station. The Micro radio is equipped with changeable crystals that allow you to change the frequency/channel you operate on. This is especially useful when you want to run a group of Losi Micro's at the same time. When changing crystals/channels, you must always replace the crystals as a set with one going in both the transmitter and the receiver in the truck. Each of the 6 different channels are numbered and color-coded. Each set includes a unique crystal for the receiver marked (Rx) and one from the transmitter marked (Tx). The crystals are changed by gently pulling them out, later lining up the two pins of each crystal with its socket, then carefully pushing the new crystals into place. **DO NOT** force them as damage can occur. If they do not slide into the socket easily check for bent or misaligned pins.

Channel 1	Brown	26.995MHz	(LOSB1094)
Channel 2	Red	27.045MHz	(LOSB1095)
Channel 3	Orange	27.095MHz	(LOSB1096)
Channel 4	Yellow	27.145MHz	(LOSB1097)
Channel 5	Green	27.195MHz	(LOSB1098)
Channel 6	Blue	27.255MHz	(LOSB1099)

Crystal Socket



Making Adjustments

The following are simple adjustments and easily maintained settings that will assure proper operation and performance. The Losi Micro-HIGHroller comes from the factory with optimum settings; we suggest first-time RC drivers leave these as they are and simply maintain them as necessary. Only after gaining experience should new drivers try **experimenting with different settings**.

Slipper Adjustments

The Losi Micro-HIGHroller is equipped with a slipper device that offers both traction control and protection for the transmission. The slipper is primarily used to help absorb sudden impacts on the drivetrain due to landing big jumps or when using more powerful after-market motors and/or battery packs. Additionally, it can be used to smooth out the flow of power to the rear wheels and limit wheel spin when running on extremely slick surfaces. Adjustments are made using a 4.5mm nut driver and adjusting the slipper nut clockwise (to the right) to reduce the slip or counterclockwise (to the left) to increase the slip.

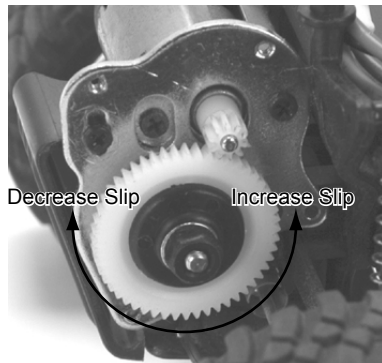

When adjusted properly, you should be able to hold the rear tires firmly and barely be able to push the spur gear forward with your thumb. To track test, turn the Losi-Micro HIGHroller on and place it on the ground. As you push it backwards, allowing it to roll freely, punch the throttle. The slipper should slip no more than an inch or two as it accelerates. Make sure you replace the gear cover before running.

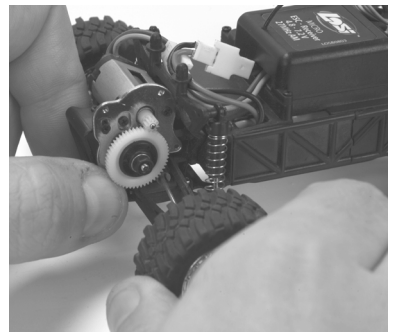

Steering Rate

Your transmitter is equipped with a steering rate control to the left of the steering wheel. This advanced feature, usually found only on competition-type radios, allows you to adjust the amount the front tires move when you turn the steering wheel. This is really helpful when you are on slick as well as high-traction surfaces. If your Micro-HIGHroller turns too sharply and/or spins out easily, try turning the steering rate down by rotating the knob counterclockwise (to the left). For sharper or additional steering, try turning the knob clockwise (to the right).



“ Less Rate”



“ Less Rate”

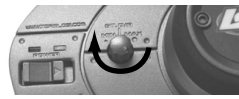

“ More Rate”



Steering Trim

The Losi Micro-HIGHroller should go straight without turning the steering wheel. If not, rotate the ST.Trim knob located to the top right of the steering wheel in the direction needed for the truck to go straight.



Adjust steering trim
to the left.



Adjust steering trim
to the right.



Cleaning

Performance can be hindered if dirt gets in any of the moving suspension parts. Use compressed air, a soft paintbrush or toothbrush to remove dust or dirt. Avoid using solvents or chemicals, as they can actually wash dirt into the bearings or moving parts as well as cause damage to the electronics.

Rebuilding the Differential

The gears in the differential wear over time. The same is true for the outdrives, driveshafts, and rear axles. We suggest using a small rag or paper towel to lay out the parts you remove to make it easier to reassemble.

1) Unplug the motor. 2) Remove the gear cover (three screws). 3) Remove the motor guard screws at the top of the transmission and the two lower extreme rear bottom of the chassis. 4) Remove the screw that attaches the rear shock tower to the transmission and the 4 long flat head screws at the bottom of the chassis that hold the gearbox in place and slide it out of the

chassis. 5) Remove the left side of the gearbox by removing the three screws. 6) Follow Figure 1 below to rebuild the differential (Use LOSA3066 Grease). 7) Once the differential has been rebuilt, assemble the transmission by following the steps in the reverse order. Be sure to use the screws in the same location that they were removed.

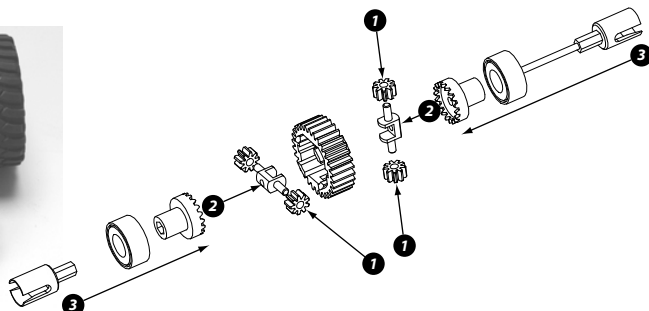

Changing the Spur Gear

Remove the gear cover by removing the three small screws. Remove the slipper adjustment nut at the end of the slipper shaft and all of the slipper parts on the outside of the spur gear as well as the old gear. Place the new spur gear into position and replace the slipper parts. After you have changed the spur gear, you will have to adjust the slipper as described in the "Slipper Adjustment" section on page 3.

Changing the Pinion Gear/Gear Ratio

Before you change the pinion, ask yourself why you are doing it. In general, if you change to a larger pinion the top speed will improve, but you will see less acceleration and run time. This would only be advisable for really long track layouts with few tight turns. Changing to a smaller pinion will give you quicker acceleration and possibly a bit longer run time but a little less top speed. This would be good for short layouts or when running faster motors. The pinion that is on the Micro-HIGHroller offers the best balance of both. To change the pinion, remove the gear cover, loosen the motor screws and slide the motor back. Use a small flat head screwdriver between the motor plate and pinion gear to push the gear off. Place the new pinion on the end of the motor shaft and press the new pinion gear into the same position as the one removed.

Setting the Gear Mesh

The motor screws should be slightly loose. Slide the motor forward allowing the pinion gear to mesh with the spur gear. Snug (not tighten) the bottom motor screw and try rocking the spur back and forth. There should be a slight bit of movement before the motor is forced to turn over. If not, pull the top of the motor back slightly and recheck. If there is too much slop between the gears, push the top of the motor forward. When set properly, the wheels can be spun forward freely with very little noise. Make sure to tighten both motor screws and replace the gear cover before running.

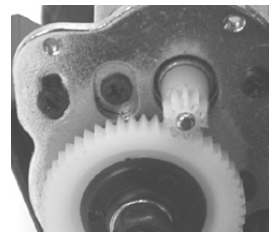

Radio Replacement/Service

If you have a radio problem please call 1-877-504-0233 for product support. Most likely, unless you have gotten the components wet, the service technician can help you fix the problem over the phone. If the problem is more severe, you may be asked to send in your vehicle and transmitter. In some cases, like a broken servo or a speed control that has failed due to getting wet, your local dealer can sell you the replacement component.

Replacing the Steering Servo

1. Unplug all wires, remove receiver crystal and 4 screws pictured in Figure 1. (Be sure to note the locations of all screws and sizes.)
2. Remove the 2 screws pictured in Figure 2, and place the PC board to the side.
3. Remove the 4 screws pictured in Figure 3. Remove the servo cover.
4. Slide the servo out from the chassis as shown in Figure 4.
5. Replace with new servo and be sure to place the tip of the servo saver into the slot of the steering bellcrank.
6. Reverse instruction order to complete servo installation.

Figure 1.

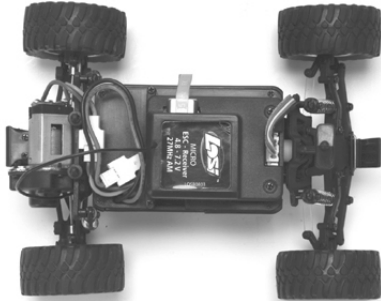

Figure 2.

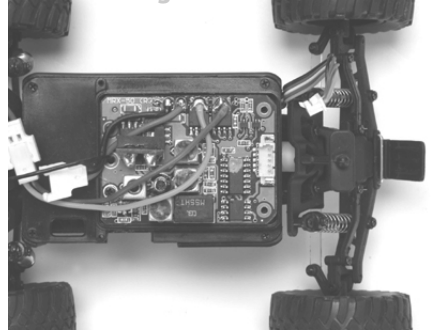

Figure 3.

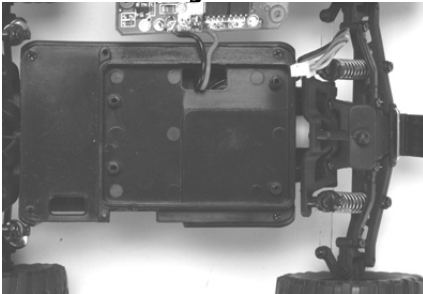
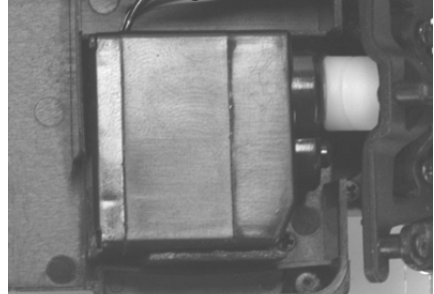

Figure 4.



Troubleshooting Guide

Doesn't operate: Battery not charged, no crystal in receiver, no crystal in transmitter, receiver switch not "on", transmitter not "on", or low battery.

Motor runs but rear wheels don't move: Pinion not meshing with spur gear or pinion spinning on motor shaft or slipper too loose or transmission gears stripped.

Steering doesn't work: Servo plug not in receiver or servo gears or servo motor damaged.

Motor doesn't run: Motor plugs loose or motor wire broken or ESC damaged.

ESC gets hot: Motor over-gear-ed or driveline bound up.

Poor run time and/or sluggish acceleration: Batteries low (need longer charge), slipper clutch slipping too much, motor worn out, driveline bound up, or wheel and axle bushing worn.

Poor range/glitching: Transmitter batteries low, transmitter antenna loose, vehicle battery low, loose plugs or wires.

Slipper won't adjust: Slipper adjustment nut worn out or spur gear face worn down.

Wheels wobble/shake: Bushing worn out.

SERVICE/REPAIR

If you have any problems other than those covered in the troubleshooting section of this operation guide, please call the Horizon Hobby Product Support line at 1-877-504-0233. They will be able to give you specific additional attention and instruct you as to what needs to be done.

Horizon Hobby Customer Service
4105 Fieldstone Rd.
Champaign, IL, 61822 USA
1-877-504-0233 www.horizonhobby.com
email: productsupport@horizonhobby.com

Warranty Period

Exclusive Warranty- Horizon Hobby, Inc., (Horizon) warrants that the Products purchased (the "Product") will be free from defects in materials and workmanship at the date of purchase by the Purchaser.

Limited Warranty

(a) This warranty is limited to the original Purchaser ("Purchaser") and is not transferable. REPAIR OR REPLACEMENT AS PROVIDED UNDER THIS WARRANTY IS THE EXCLUSIVE REMEDY OF THE PURCHASER. This warranty covers only those Products purchased from an authorized Horizon dealer. Third party transactions are not covered by this warranty. Proof of purchase is required for warranty claims. Further, Horizon reserves the right to change or modify this warranty without notice and disclaims all other warranties, express or implied.

(b) Limitations- HORIZON MAKES NO WARRANTY OR REPRESENTATION, EXPRESS OR IMPLIED, ABOUT NON-INFRINGEMENT, MERCHANTABILITY OR FITNESS FOR A PARTICULAR PURPOSE OF THE PRODUCT. THE PURCHASER ACKNOWLEDGES THAT THEY ALONE HAVE DETERMINED THAT THE PRODUCT WILL SUITABLY MEET THE REQUIREMENTS OF THE PURCHASER'S INTENDED USE.

(c) Purchaser Remedy- Horizon's sole obligation hereunder shall be that Horizon will, at its option, (i) repair or (ii) replace, any Product determined by Horizon to be defective. In the event of a defect, these are the Purchaser's exclusive remedies. Horizon reserves the right to inspect any and all equipment involved in a warranty claim. Repair or replacement decisions are at the sole discretion of Horizon. This warranty does not cover cosmetic damage or damage due to acts of God, accident, misuse, abuse, negligence, commercial use, or modification of or to any part of the Product. This warranty does not cover damage due to improper installation, operation, maintenance, or attempted repair by anyone other than Horizon. Return of any goods by Purchaser must be approved in writing by Horizon before shipment.

Damage Limits

HORIZON SHALL NOT BE LIABLE FOR SPECIAL, INDIRECT OR CONSEQUENTIAL DAMAGES, LOSS OF PROFITS OR PRODUCTION OR COMMERCIAL LOSS IN ANY WAY CONNECTED WITH THE PRODUCT, WHETHER SUCH CLAIM IS BASED IN CONTRACT, WARRANTY, NEGLIGENCE, OR STRICT LIABILITY. Further, in no event shall the liability of Horizon exceed the individual price of the Product on which liability is asserted. As Horizon has no control over use, setup, final assembly, modification or misuse, no liability shall be assumed nor accepted for any resulting damage or injury. By the act of use, setup or assembly, the user accepts all resulting liability.

If you as the Purchaser or user are not prepared to accept the liability associated with the use of this Product, you are advised to return this Product immediately in new and unused condition to the place of purchase.

Law: These Terms are governed by Illinois law (without regard to conflict of law principals).

Safety Precautions

This is a sophisticated hobby Product and not a toy. It must be operated with caution and common sense and requires some basic mechanical ability. Failure to operate this Product in a safe and responsible manner could result in injury or damage to the Product or other property. This Product is not intended for use by children without direct adult supervision. The Product manual contains instructions for safety, operation and maintenance. It is essential to read and follow all the instructions and warnings in the manual, prior to assembly, setup or use, in order to operate correctly and avoid damage or injury.

Questions, Assistance, and Repairs

Your local hobby store and/or place of purchase cannot provide warranty support or repair. Once assembly, setup or use of the Product has been started, you must contact Horizon directly. This will enable Horizon to better answer your questions and service you in the event that you may need any assistance. For questions or assistance, please direct your email to productsupport@horizonhobby.com, or call 877.504.0233 toll free to speak to a service technician.

Inspection or Repairs

If this Product needs to be inspected or repaired, please call for a Return Merchandise Authorization (RMA). Pack the Product securely using a shipping carton. Please note that original boxes may be included, but are not designed to withstand the rigors of shipping without additional protection. Ship via a carrier that provides tracking and insurance for lost or damaged parcels, as **Horizon is not responsible for merchandise until it arrives and is accepted at our facility**. A Service Repair Request is available at www.horizonhobby.com on the "Support" tab. If you do not have internet access, please include a letter with your complete name, street address, email address and phone number where you can be reached during business days, your RMA number, a list of the included items, method of payment for any non-warranty expenses and a brief summary of the problem. Your original sales receipt must also be included for warranty consideration. Be sure your name, address, and RMA number are clearly written on the outside of the shipping carton.

Warranty Inspection and Repairs

To receive warranty service, you must include your original sales receipt verifying the proof-of-purchase date. Provided warranty conditions have been met, your Product will be repaired or replaced free of charge. Repair or replacement decisions are at the sole discretion of Horizon Hobby.

Non-Warranty Repairs

Should your repair not be covered by warranty the repair will be completed and payment will be required without notification or estimate of the expense unless the expense exceeds 50% of the retail purchase cost. By submitting the item for repair you are agreeing to payment of the repair without notification. Repair estimates are available upon request. You must include this request with your repair. Non-warranty repair estimates will be billed a minimum of ½ hour of labor. In addition you will be billed for return freight. Please advise us of your preferred method of payment. Horizon accepts money orders and cashiers checks, as well as Visa, MasterCard, American Express, and Discover cards. If you choose to pay by credit card, please include your credit card number and expiration date. Any repair left unpaid or unclaimed after 90 days will be considered abandoned and will be disposed of accordingly. **Please note: non-warranty repair is only available on electronics and model engines.**

Electronics and engines requiring inspection or repair should be shipped to the following address:

**Horizon Service Center
4105 Fieldstone Road
Champaign, Illinois 61822 USA**

All other Products requiring warranty inspection or repair should be shipped to the following address:

**Horizon Product Support
4105 Fieldstone Road
Champaign, Illinois 61822 USA**

Please call 877-504-0233 with any questions or concerns regarding this product or warranty.

United Kingdom

Electronics and engines requiring inspection or repair should be shipped to the following address:

**Horizon Hobby UK
Units 1-4 Ployters Rd
Staple Tye, Harlow
Essex
CM18 7NS
United Kingdom**

Please call +44 (0) 1279 641 097 or email us at sales@horizonhobby.co.uk with any questions or concerns regarding this product or warranty.

Germany

Electronics and engines requiring inspection or repair should be shipped to the following address:

**Horizon Technischer Service
Hamburger Str. 10
25335 Elmshorn, Germany**

Please call +49 4121 46199 66 or email us at anservice@horizonhobby.de with any questions or concerns regarding this product or warranty.

CE Compliance Information for the European Union Instructions for Disposal of WEEE by Users in the European Union

This product must not be disposed of with other waste. Instead, it is the user's responsibility to dispose of their waste equipment by handing it over to a designated collection point for the recycling of waste electrical and electronic equipment. The separate collection and recycling of your waste equipment at the time of disposal will help to conserve natural resources and ensure that it is recycled in a manner that protects human health and the environment. For more information about where you can drop off your waste equipment for recycling, please contact your local city office, your household waste disposal service or where you purchased the product.

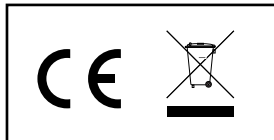

Declaration of Conformity

(in accordance with ISO/IEC 17050-1)

No. HH20090816

Product(s): LOS 1/36 Micro-HIGHroller

Item Number(s): LOSB0237

Equipment class: 1

The object of declaration described above is in conformity with the requirements of the specifications listed below, following the provisions of the European R&TTE directive 1999/5/EC:

EN 300-220	Technical requirements for Radio equipment.
EN 301 489-3	General EMC requirements

Signed for and on behalf of:
Horizon Hobby, Inc.
Champaign, IL USA
Aug 16, 2009

Steven A. Hall
Vice President
International Operations and Risk Management
Horizon Hobby, Inc.

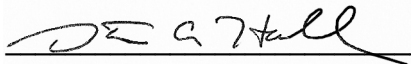

MICRO HIGH ROLLER

1/36-SCALE ELECTRIC RTR LIFTED TRUCK



WWW.LOSI.COM

Horizon Hobby, Inc.
4105 Fieldstone Road
Champaign, IL 61822