



AR635 User Guide

AR635 Bedienungsanleitung

Guide de l'utilisateur - AR635

AR635 Guida dell'utente

NOTICE

All instructions, warranties and other collateral documents are subject to change at the sole discretion of Horizon Hobby, Inc. For up-to-date product literature, visit horizonhobby.com and click on the support tab for this product.

Meaning of Special Language

The following terms are used throughout the product literature to indicate various levels of potential harm when operating this product:

NOTICE: Procedures, which if not properly followed, create a possibility of physical property damage AND a little or no possibility of injury.

CAUTION: Procedures, which if not properly followed, create the probability of physical property damage AND a possibility of serious injury.

WARNING: Procedures, which if not properly followed, create the probability of property damage, collateral damage, and serious injury OR create a high probability of superficial injury.

 **WARNING:** Read the ENTIRE instruction manual to become familiar with the features of the product before operating. Failure to operate the product correctly can result in damage to the product, personal property and cause serious injury.

This is a sophisticated hobby product. It must be operated with caution and common sense and requires some basic mechanical ability. Failure to operate this Product in a safe and responsible manner could result in injury or damage to the product or other property. This product is not intended for use by children without direct adult supervision. Do not attempt disassembly, use with incompatible components or augment product in any way without the approval of Horizon Hobby, Inc. This manual contains instructions for safety, operation and maintenance. It is essential to read and follow all the instructions and warnings in the manual, prior to assembly, setup or use, in order to operate correctly and avoid damage or serious injury.

 **WARNING AGAINST COUNTERFEIT PRODUCTS**

Always purchase from a Horizon Hobby, Inc. authorized dealer to ensure authentic high-quality Spektrum product. Horizon Hobby, Inc. disclaims all support and warranty with regards, but not limited to, compatibility and performance of counterfeit products or products claiming compatibility with DSM or Spektrum technology.

**Age Recommendation: Not for children under 14 years.
This is not a toy.**

NOTICE: This product is only intended for use with unmanned, hobby-grade, remote-controlled vehicles and aircraft. Horizon Hobby disclaims all liability outside of the intended purpose and will not provide warranty service related there to.

WARRANTY REGISTRATION

Visit www.spektrumrc.com/registration today to register your product.

AR635 User Guide

The AR635 combines the breakthrough performance of AS3X® technology with a Spektrum™ 6-channel, 2048 receiver. This combination along with Quique Somenzini's perfection of simple programming logic and tuned flight stabilization provides the ultimate in performance and simple installation. The AR635 is perfect for Park flyer aircraft to .90-sized electric aircraft. The AR635 is not to be used with nitro, gas, or turbine-powered aircraft. While the AR635 provides maximum agility and precision for intermediate and professional pilots, it is not a flying aid for beginners. The AR635 AS3X electronic enhancement system makes it possible for you to experience super-smooth flight performance, yet still have full control authority for sport or 3D flight. Turbulence, torque and tip stalls are just some of the many complications to assess when trying to achieve smooth flight. The AS3X System invisibly helps with complicated corrections, allowing you to experience ultra smooth flight performance that feels so natural, you'll quickly build confidence in the capability of the airplane. The AR635 setup is easy. Just bind your compatible Spektrum, JR® or 2.4GHz DSM2®/DSMX® technology transmitter to your AR635 to innovate the way you'll want to fly now and in the future.

NOTICE: The AR635 receiver is not compatible with the DX6 park flyer radio system.

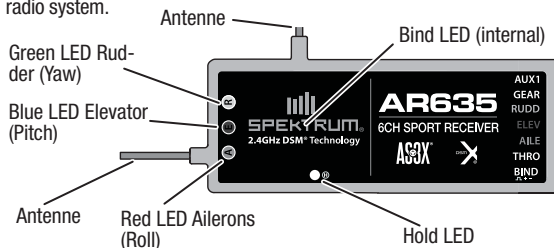

Features

- A unique design in cooperation with Spektrum and Quique Somenzini
- Integrated AS3X technology
- Simple programming logic
- Flight stabilization programming tuned by Quique Somenzini
- 3-axis gain adjustment
- Computer and non-computer radio compatible
- 2048 Resolution)
- 22 ms operation

Applications

Park flyer - .90 size Electric Aircraft ONLY.

CAUTION: Do not use the AR635 receiver in nitro, gas or turbine-powered aircraft or in electric aircraft larger than .90-size. Doing so may cause damage to the aircraft and result in property damage or injury. Always read and follow all instructions to properly program the AS3X system.

AR635 Specifications

Type:	DSM2/DSMX AS3X receiver
Channels:	6
Modulation:	DSM2/DSMX
Dimension:	(WxLxH): 22 x 56 x 14 mm
Weight:	13.2 g
Input Voltage Range:	3.5 to 8.5V
Resolution:	2048
Compatibility:	All DSM2/DSMX aircraft transmitters

Receiver Installation

Make sure the receiver is mounted firmly and cannot move during aircraft maneuvers or loosen in the event of harmonic vibration. We recommend securing the receiver with high-quality, double-sided tape.

You can install the receiver longitudinally (inverted or upright) in a low vibration position; however, the servo connector pins must always point toward the front or rear of the aircraft.

ONLY install the receiver into your aircraft in the following orientations.

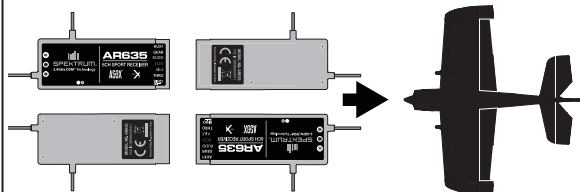

CAUTION: If AS3X is active and the receiver is not installed correctly, the aircraft will crash.

Antenna Polarization

For optimum RF link performance, mount the antennas in an orientation that allows for the best possible signal reception when the aircraft is in all possible attitudes and positions. Orient the internal receiver antennas perpendicular to each other.

Hold Indicator

The AR635 features a red LED (Indicated by **H**). This LED indicates the number of holds that have occurred since the receiver was last powered on. The LED will flash the number of holds, then pause (e.g., flash, flash, flash, pause, flash, flash, flash, pause) This indicates three holds. Holds are reset to zero when the receiver is turned off.

During the first flights of a new airplane, it's recommended to check the red LED hold indicator.

If it's flashing, it's important to optimize the installation (move or reposition antennas) until no hold occurs. On later flights, the LED Hold Indicator can be used to confirm RF link performance.

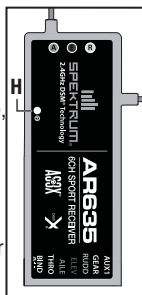

Servo Selection

Select servos that are adequate for AS3X operation. The servos must be digital, high speed and high resolution. A poor servo/linkage geometry combination will cause several issues, including oscillations and unwanted reaction.

Y-Harnesses and Servo Extensions

Do not use amplified Y-harnesses and servo extensions with Spektrum equipment. Only use standard, non-amplified Y-harnesses and servo extensions. When converting existing models to Spektrum devices, replace all amplified Y-harnesses and servo extensions.

Setting Up the Transmitter

Non-Computer Transmitter

We recommend enabling Exponential (if available) and using high rates with Non-Computer transmitters for the best performance. If you need to use low rates, or need to disable Exponential to match your flying style, you can do so without affecting the performance of the AS3X system.

Computer Transmitter

Total Servo travel **MUST** be set to 125%. Changing the servo total travel from 125% will affect the tuning and performance of the AS3X technology. Always mechanically adjust the aircraft linkages for less control surface throw while maintaining 125% servo travel.

If you choose to use transmitter Dual Rates, **NEVER** use a value lower than 50%. Doing so will severely affect the performance of the receiver. If you are using a computer transmitter, we recommend using the following values:

- **Servo Travel:** 125% on Aileron, Elevator and Rudder
- **Dual Rate:** Maximum of 100% and a minimum of 50%
- **Exponential:** 20% on Aileron, Elevator and Rudder



CAUTION: The AR635 is not compatible with Delta, V-tail, or Flaperon mixing. If using dual ailerons, elevator or rudder, a Y harness must be used.

IMPORTANT: The Dual Rate value must be between 50% and 100%. Exponential can be adjusted to best fit your flying style.

Binding

You must bind the receiver to the transmitter before the receiver will operate. Binding is the process of programming the receiver to recognize the GUID (Globally Unique Identifier) code of a single specific transmitter. To bind the AR635 receiver to a DSM2 or DSMX transmitter:

1. Insert the bind plug in the BIND port on the receiver.
2. Power on the receiver. The receiver can be powered through any open port. The bind LED on the receiver flashes, indicating the receiver is in bind mode. To bind the receiver using an electronic speed controller, insert the bind plug into the BIND port in the receiver and the ESC lead into the throttle (THRO) port.
3. Keep the plane motionless for 5 seconds.
4. Move the throttle stick to the low throttle position.
5. Put your transmitter in Bind Mode. The system connects within a few seconds. Once connected, the orange LED light turns solid and the AR635 receiver begins the initialization process. At this point, the gain lights should be flashing at the preset gain values.
6. After setting up your model, rebind the system so the true low throttle position is set in the failsafe.
7. Remove the bind plug from the BIND port on the receiver before you power off the receiver and transmitter. Store the bind plug in a convenient place.



AR635 with bind plug inserted

NOTICE: Always remove the bind plug to prevent the system from entering bind mode the next time you power on the receiver.

The ESC will not arm if the throttle control is not put at the lowest position. If you encounter problems, follow the binding instructions and refer to the transmitter troubleshooting guide for other instructions. If needed, contact the appropriate Horizon Product Support office.

Receiver Setup Procedure

The Spektrum AR635 receiver offers LED programming and the following adjustable features:

- **3D Airplane:** Non-Computer transmitter
- **3D Airplane:** Computer transmitter
- **Sport Airplane:** All Transmitters

If you select a 3D Airplane transmitter, 5 channels are available for aircraft controls. The Gear channel is reserved for Flight Modes. The Sport Airplane transmitter selection enables you to use all 6 channels; Flight Modes for Gear Up and Gear Down are activated by the Gear channel.

After you select the transmitter type, complete a control direction test to ensure the control surfaces are moving in the correct direction. Any necessary channel reversing is done at this time in the transmitter. It is extremely important to complete the control direction test before proceeding to gain adjustment. The gain adjustment controls are dependent on the transmitter channel reverse values.

Once you enter the Gain Control menus, use three LED lights to navigate the menu options. Thoroughly review the Gain Control section before attempting to change any gain values in the receiver. The color of the LED indicates the active axis (Aileron, Elevator or Rudder), while the LED pattern (On, Off or Flashing) will help you navigate the menu and gain values.

Enter Transmitter Type

Computer and Non-Computer Radios

The AR635 receiver is compatible with both “non-computer” as well as “computer” radios. Each receiver mode (3D Non-Computer, 3D Computer or Sport all transmitters) stores the specific gain values for each transmitter type. The designation of “non-computer” and “computer” radio is determined by the travel adjust capabilities of the transmitter. All radios capable of at least 125% servo travel are grouped in the “computer radio” section. Radios with less than 125% servo travel are grouped in the “non-computer radio” section.

NOTICE: Be sure the transmitter binds to the receiver and check basic functions. Once basic function is established, the receiver can be powered off.

3D Non-Computer:

1. With the transmitter powered ON, move the throttle stick to the middle position.
2. Hold full Left Aileron and full Down Elevator while powering on the receiver. After 5 seconds, the red and blue LEDs in the receiver turn solid, indicating that you have successfully entered 3D Non-Computer Radio mode.
3. Release the transmitter stick(s).

Entering Transmitter Type by Stick Combination:

IMPORTANT: Aileron and Elevator Reversing must be set to Normal/Normal

Non-Computer Transmitters: 3D

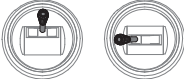
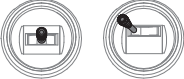
Mode 1	
Mode 2	

IMPORTANT: General Flight mode and 3D mode are toggled using the Gear switch (DX4e AUX switch).

EXIT MENU: Move the controls to neutral, then throttle full down to exit the menu. The ESC will regain control.

3D Computer:

1. With the transmitter powered ON, move the throttle stick to the middle position.
2. Hold full Right Aileron and full Down Elevator while powering on the receiver. After 5 seconds, the blue and green LEDs in the receiver turn solid, indicating that you have successfully entered 3D Computer Radio mode.
3. Release the transmitter stick(s).

Entering Transmitter Type by Stick Combination:

IMPORTANT: Aileron and Elevator Reversing must be set to Normal/Normal

Computer Transmitters: 3D

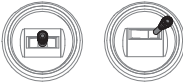
Mode 1	
Mode 2	

IMPORTANT: General Flight mode and 3D mode are toggled using the Gear switch.

EXIT MENU: Move the controls to neutral, then throttle full down to exit the menu. The ESC will regain control.



Sport Mode, All Transmitters:

1. With the transmitter powered ON, move the throttle stick to the middle position.
2. Hold full Left Aileron and full Up Elevator while powering on the receiver. After 5 seconds, the green, blue, and red LEDs in the receiver turn solid, indicating that you have successfully entered Sport mode.
3. Release the transmitter stick(s).

Entering Transmitter Type by Stick Combination:

IMPORTANT: Aileron and Elevator Reversing must be set to Normal/Normal

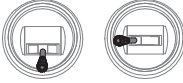
All Transmitters: Sport





















Mode 1	
Mode 2	

IMPORTANT: Two gain banks are toggled using the Gear switch (DX4e AUX switch).

EXIT MENU: Move the controls to neutral, then throttle full down to exit the menu. The ESC will regain control.

Enter Gain Control

To access the Gain Control Mode, the transmitter must use a specific stick combination. With the transmitter powered ON, hold the sticks as shown in the chart below while powering on the receiver.

Aileron / Elevator Reversing		Entering Gain Control by Stick Combination:			
		Mode 1		Mode 2	
Aileron	Elevator				
N	N				
N	R				
R	N				
R	R				

Gain Adjustment

The gain is grouped in steps and can be changed by moving the Aileron stick left or right. With the transmitter servo reversing set to normal, Right input is a Positive (+) step, while left input is a Negative (-) step. Each input represents one 10 % gain value up to +/- 100%. There are 20 gain values; the 0 value turns the sensor off in that axis. Every time the aileron stick is moved to right, then released to neutral, 10% gain is added. Every time the aileron stick is moved to the left, then released to neutral, 10% gain is deducted. For example; if the gain value = +80% and the aileron stick is moved one time to the left and released to neutral, the gain value will now = +70%

NOTICE: During gain adjustment, power is still supplied to the servos. Aileron, Elevator and Rudder will respond to stick movement. All other channels (Throttle) will not be active.

Transmitter Aileron Channel Normal

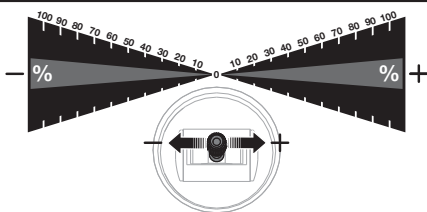



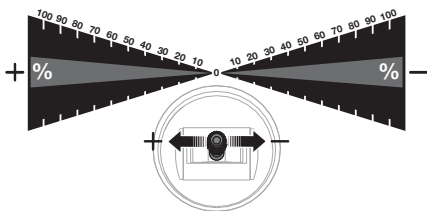

Transmitter Aileron Channel Reversed

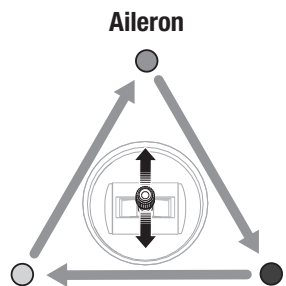

Axis Selection (Roll, Pitch, Yaw)

The elevator stick selects the axis for gain adjustment. Moving the elevator stick up or down moves the 3 LED's in a continuous loop. From the roll axis (Red solid), push the elevator stick once to change to pitch axis (Blue solid), then push the elevator stick again to change to rudder axis (Green Solid). If the elevator stick is pulled, it goes in the opposite direction.

Once you select an axis, all 3 LEDs will flash, indicating you are in the gain setup mode for that axis.

Elevator Stick	LEDs	
		Red: Roll (Aileron)
		Blue: Pitch (Elevator)
		Green: Yaw (Rudder)

Lights

All three LEDs will **flash three times**, indicating you have entered the gain setup mode successfully. When an individual Axis (Roll/Pitch/Yaw) is selected, the light assigned for that axis will turn solid. The gain value and sensing direction will be represented by the remaining two lights. The receiver programming lights can be seen through the transparent smoke gray receiver case for programming:

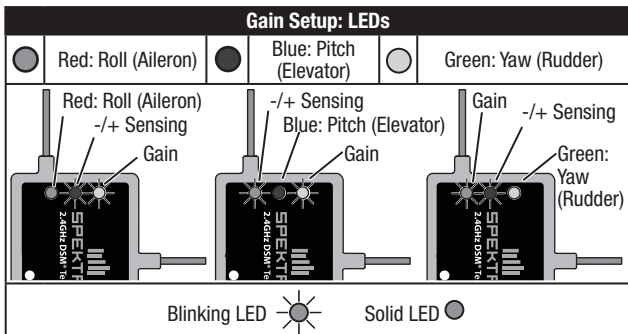

Axis selected:

Solid Light

Axis gain value (10–100):

When the value is zero, this LED will be OFF. When a gain value is input, the LED will start to blink. The higher the gain value, the more rapid the blinking. A gain value of 100% will give the highest rate of blinking.

Axis sensing direction (value +/-):

When the value is Negative, the represented LED will blink very rapidly. When the value is positive, the represented LED will blink 3 times a second.

The axis being adjusted will always remain solid. Maxing out the negative direction and then counting ten right aileron inputs (+) will give you zero (0) gain. The light indicating the axis gain value LED will be off. A rapid flashing LED indicates a positive or negative gain.

EXIT MENU: Move the controls to neutral, then throttle full down to exit the menu. The ESC will regain control.

NOTICE: During gain adjustment, power is still supplied to the servos. Aileron, Elevator and Rudder will respond to stick movement. All other channels (Throttle) will not be active.

Sensor/Servo Direction and Compensation

It is extremely important to make sure that the sensors are compensating in the desired direction prior to the first flight.

NOTICE: AS3X will not turn on until the throttle is advanced. Once the throttle is advanced, AS3X will remain on until the radio is turned off.

IMPORTANT: Before adjusting gain values for any axis, make sure the servo is traveling in the correct direction (if you're unsure, seek help from someone more experienced). If the servo is moving in the incorrect direction, reverse the servo in the transmitter.

Rudder

Pick up the airplane and quickly move the nose to the left. The rudder should move to the right as shown. If it moves in the opposite direction, enter Gain Mode and change the sensing direction to the opposite direction.

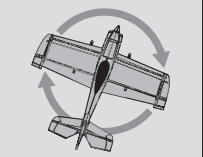
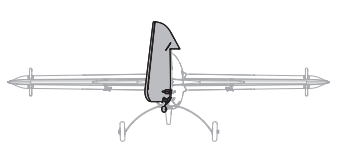
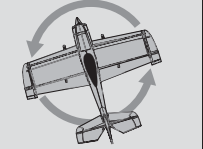
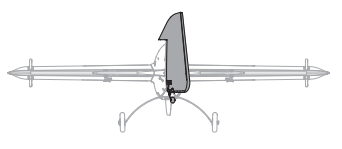
	Aircraft movement	AS3X Reaction
Rudder		
		

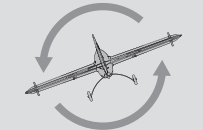
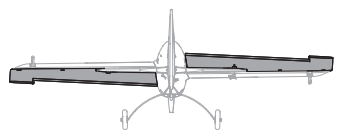
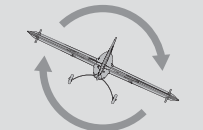
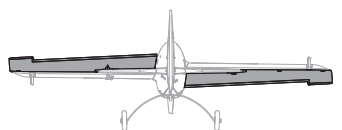

Aileron

Pick up the airplane and quickly move the right wing panel downward. The right aileron should move in the same direction (down). If it moves in the opposite direction, enter Gain Mode and change the sensing direction to the opposite direction.

	Aircraft movement	AS3X Reaction
Aileron		
		

Elevator

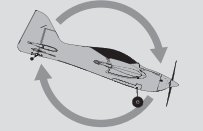
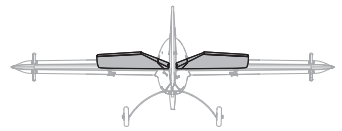
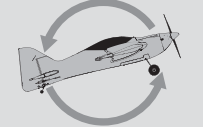
Pick up the airplane and quickly move the Nose of the airplane downward. The elevator should move in the up direction. If it moves in the opposite direction, enter Gain Mode and change the sensing direction to the opposite direction.

	Aircraft movement	AS3X Reaction
Elevator		
		

Flight Mode

Flight modes are controlled by the gear channel on all radios (Channel 5). On the DX4e transmitter, the flight modes are controlled by the ACT/AUX switch. You can adjust the amount of gain on each axis for both switch positions (0 and 1), giving you a total of 6 gain values.

3D Mode:			
	Aileron	Elevator	Rudder
3D Flight (Gear SW Pos 1)	80%	80%	90%
General Flight (Gear SW Pos 0)	40%	20%	30%

We recommend using higher gain values for 3D Flight (slower air speed and larger control surface throws). Use lower gain values for General Flight (faster air speed and smaller control surface throws).

The AR635 receiver is also pre-programmed with a set of Dual Rate values for both 3D Flight Mode positions (Gear Switch). The pre-programmed values in the receiver cannot be adjusted. Any TRANSMITTER Dual Rate or Expo values you choose will be used in conjunction with the pre-programmed values

Sport Mode:			
	Aileron	Elevator	Rudder
Gear up (Gear SW Pos 1)	70%	70%	70%
Gear Down (Gear SW Pos 0)	70%	70%	70%













We recommend using higher gain values for Gear Down (slower air speed). Use lower gain values for General Flight Gear Up (faster air speed).

Information Storage

When the user enters the gain menu, each axis will show gain values previously entered. If the unit is new and has never been programmed, it will show the default setting. The gain value of each axis remains the same value that was previously entered. In this way, each axis of any of the two Flight Modes can be changed at any time. For example, if the gain value for pitch in the 3D flight mode needs to be changed, enter the menu and push the elevator as many times as needed until the pitch light is solid, then use aileron to change the existing value. When that value is adjusted, throttle full down and exit the menu. All other gain settings remain as they were.

Factory Default Gain Settings

To access to factory default gain settings of the AR635, a transmitter stick combination must be used. With the transmitter powered ON, hold full right rudder in combination with throttle full down, then power ON the receiver. After 5 seconds, the red and green LEDs will turn solid, indicating all gain values have been restored to default settings. Release the rudder stick. See the figure below for stick combinations:

Restore Gain to Factory Default Stick Combination:		Mode 1		Mode 2	
Throttle/Rudder Reversing					
Throttle	Rudder				
N	N				
N	R				

EXIT MENU: Move the controls to neutral, then throttle full down to exit the menu. The ESC will regain control.

Initializing the AR635

Once the AR635 receiver has been programmed and the correct sensing direction has been selected, it is very important to power OFF the receiver, then power it back ON to initialize the sensors. Place the aircraft on the ground out of the wind, then power the receiver ON. Ensure the aircraft is immobile for 5 seconds so the AS3X system initializes correctly.

The AS3X system will not activate until the throttle stick or trim is increased for the first time. Once the AS3X is active, the control surfaces may move rapidly on the aircraft. This is normal. AS3X will remain active until the AR635 is powered off.

 **CAUTION:** Always complete a control direction test with the transmitter and make sure the sensors are correcting in the proper directions when you roll, yaw, and pitch the aircraft.

The three LEDs will indicate the gain value for each specific axis by the rate of the blinking light. High gain is represented by a more frequent blinking LED, low gain by a less frequent blinking. At zero gain the LED is OFF.

Adjust the gain at the airfield

Always take off with a VERY conservative gain. Slowly increase gain until you reach the oscillation point. From that point, back off a step or two and you should be in the pick of your gain. When flying a brand new airplane, always takeoff with the flight mode set at General Flight. Partially increase the airspeed (increase throttle) until you see if the plane oscillates.

If you see oscillation, immediately reduce airspeed/throttle. Once you detect oscillation, identify what axis needs to have the gain adjusted. If it's a windy day, take the wind factor in consideration (plane speed is relative to the air and NOT to ground) Once you get this process right for General Flight Mode, do the same exercise with the 3D mode.

Set your 3D mode gain higher, perhaps only to fly up to 1/2 to 3/4 airspeed. This will give the AS3X system more authority for corrections.

AR635 Power System Requirements

All receivers require uninterrupted power. AS3X demands more current from the servos due to the “non-stop” activity. During even a short duration power interruption/brownout, the AS3X sensor must reboot and re-initialize.

 **WARNING:** If a power interruption/brownout occurs during flight, a crash will occur. It is your responsibility to ensure the AR635 has sufficient power without interruption.

Some of the power system components that affect the ability to properly deliver adequate power include:

- Only use this receiver with AS3X-compatible ESCs.
- The ESC's BEC capability to deliver current to the receiver when load is placed on the servos. This is the #1 cause of power interruptions in electric powered aircraft. Use only AS3X-friendly ESCs
- The switch harness, battery leads, servo leads, regulators, etc.
- Receiver battery pack (number of cells, capacity, cell type, state of charge)

The AR635 has a minimum operational voltage of 3.5 volts; it is highly recommended the power system be tested per the following guidelines.

Recommended Power System Test Guidelines

Perform the following test with a voltmeter or servo current meter (HAN172). Plug the Servo Current Meter (HAN172) into the Bind port in the receiver and, with the system on, rapidly move the control sticks (stir the sticks) with no load on the servos for 3 minutes. Monitor the voltage at the receiver. It is important to rapidly move the control sticks for 3 minutes. If a voltage regulator becomes hot, it can lose its ability to supply current. An alternate method is to power on the system and load the servos by applying pressure to the control surfaces with your hand for 3 minutes. The voltage should remain above 4.8 volts in both cases.

SmartSafe™ Failsafe

SmartSafe technology is a safety feature on the throttle channel only that offers the following benefits:

- Prevents electric motors from operating when the receiver only is turned on (no transmitter signal present)
- Prevents the speed controller from arming until the throttle is moved to low throttle position after connection is made
- Powers off electric motors and reduces gas/glow engines to idle if signal is lost (must bind the receiver at throttle off or idle position).
- If throttle is at any position other than low, the ESC won't arm
- If connection is lost in flight, **SmartSafe** technology sets the throttle to the position it was in during the binding process (normally low throttle or idle).

How to Program SmartSafe Failsafe

SmartSafe is automatically set when the system is bound. It's important to have the throttle stick in the low position to store low throttle settings during binding.



CAUTION: For electric aircraft, always remove the propeller from the motor before testing the failsafe.

Range Testing

Before each flying session, and especially with a new model, perform a range check. All Spektrum aircraft transmitters incorporate a range testing system which, when activated, reduces the output power, allowing a range check.

1. With the model on the ground and the motor off, stand 30 paces (approx. 90 feet/28 meters) away from the model.
2. Face the model with the transmitter in your normal flying position and place your transmitter into range check mode. This causes reduced power output from the transmitter.
3. You should have total control of the model in range test mode at 30 paces (approx. 90 feet/28 meters)
4. If control issues exist, call the Horizon Product Support office.

2.4GHz Troubleshooting Guide

AS3X

Problem	Possible Cause	Solution
Oscillation	Flying over recommended airspeed in 3D mode	Switch to GF mode
	Damaged propeller	Replace propeller
	Imbalanced propeller	Balance the propeller
	Motor vibration	Replace parts or correctly align all parts and tighten fasteners as needed
	Loose receiver	Align and secure receiver in fuselage
	Loose aircraft controls	Tighten or otherwise secure parts (servo, arm, linkage, horn and control surface)
	Flight condition variations	Adjust gain to current flight conditions (wind, updrafts, local conditions (altitude above sea level, humidity, temperature, etc.))
	Worn parts	Adjust gain to compensate for parts wear or replace worn parts (especially propeller, pivot points or servo)
	Irregular servo rotation	Replace servo
	Incorrect transmitter type (computerized or non-computerized) assigned in receiver	Assign correct transmitter type in the receiver
If oscillation persists...	Decrease gain	
Trim change when flight mode is switched	Trim is not at neutral	If you adjust trim more than 8 clicks, adjust the clevis to remove trim
	Sub-trim is not at neutral	No Sub-trim is allowed. Adjust the servo arm or the clevis
Incorrect response to the AS3X Control Direction Test.	Incorrect direction settings in the receiver, which can cause a crash	DO NOT fly. Correct the direction settings (refer to the receiver manual), then fly.

1-Year Limited Warranty

What this Warranty Covers

Horizon Hobby, Inc., (Horizon) warrants to the original purchaser that the product purchased (the "Product") will be free from defects in materials and workmanship for a period of 1 years from the date of purchase.

What is Not Covered

This warranty is not transferable and does not cover (i) cosmetic damage, (ii) damage due to acts of God, accident, misuse, abuse, negligence, commercial use, or due to improper use, installation, operation or maintenance, (iii) modification of or to any part of the Product, (iv) attempted service by anyone other than a Horizon Hobby authorized service center, (v) Product not purchased from an authorized Horizon dealer, or (vi) Product not compliant with applicable technical regulations.

OTHER THAN THE EXPRESS WARRANTY ABOVE, HORIZON MAKES NO OTHER WARRANTY OR REPRESENTATION, AND HEREBY DISCLAIMS ANY AND ALL IMPLIED WARRANTIES, INCLUDING, WITHOUT LIMITATION, THE IMPLIED WARRANTIES OF NON-INFRINGEMENT, MERCHANTABILITY AND FITNESS FOR A PARTICULAR PURPOSE. THE PURCHASER ACKNOWLEDGES THAT THEY ALONE HAVE DETERMINED THAT THE PRODUCT WILL SUITABLY MEET THE REQUIREMENTS OF THE PURCHASER'S INTENDED USE.

Purchaser's Remedy

Horizon's sole obligation and purchaser's sole and exclusive remedy shall be that Horizon will, at its option, either (i) service, or (ii) replace, any Product determined by Horizon to be defective. Horizon reserves the right to inspect any and all Product(s) involved in a warranty claim. Service or replacement decisions are at the sole discretion of Horizon. Proof of purchase is required for all warranty claims. SERVICE OR REPLACEMENT AS PROVIDED UNDER THIS WARRANTY IS THE PURCHASER'S SOLE AND EXCLUSIVE REMEDY.

Limitation of Liability

HORIZON SHALL NOT BE LIABLE FOR SPECIAL, INDIRECT, INCIDENTAL OR CONSEQUENTIAL DAMAGES, LOSS OF PROFITS OR PRODUCTION OR COMMERCIAL LOSS IN ANY WAY, REGARDLESS OF WHETHER SUCH CLAIM IS BASED IN CONTRACT, WARRANTY, TORT, NEGLIGENCE, STRICT LIABILITY OR ANY OTHER THEORY OF LIABILITY, EVEN IF HORIZON HAS BEEN ADVISED OF THE POSSIBILITY OF SUCH DAMAGES. Further, in no event shall the liability of Horizon exceed the individual price of the Product on which liability is asserted. As Horizon has no control over use, setup, final assembly, modification or misuse, no liability shall be assumed nor accepted for any resulting damage or injury. By the act of use, setup or assembly, the user accepts all resulting liability. If you as the purchaser or user are not prepared to accept the liability associated with the use of the Product, purchaser is advised to return the Product immediately in new and unused condition to the place of purchase.

Law

These terms are governed by Illinois law (without regard to conflict of law principals). This warranty gives you specific legal rights, and you may also have other rights which vary from state to state. Horizon reserves the right to change or modify this warranty at any time without notice.

WARRANTY SERVICES

Questions, Assistance, and Services

Your local hobby store and/or place of purchase cannot provide warranty support or service. Once assembly, setup or use of the Product has been started, you must contact your local distributor or Horizon directly. This will enable Horizon to better answer your questions and service you in the event that you may need any assistance. For questions or assistance, please visit our website at www.horizonhobby.com, submit a Product Support Inquiry, or call 877.504.0233 toll free to speak to a Product Support representative.

Inspection or Services

If this Product needs to be inspected or serviced and is compliant in the country you live and use the Product in, please use the Horizon Online Service Request submission process found on our website or call Horizon to obtain a Return Merchandise Authorization (RMA) number. Pack the Product securely using a shipping carton. Please note that original boxes may be included, but are not designed to withstand the rigors of shipping without additional protection. Ship via a carrier that provides tracking and insurance for lost or damaged parcels, as Horizon is not responsible for merchandise until it arrives and is accepted at our facility. An Online Service Request is available at Horizon Hobby Service Center. If you do not have internet access, please contact Horizon Product Support to obtain a RMA number along with instructions for submitting your product for service. When calling Horizon, you will be asked to provide your complete name, street address, email address and phone number where you can be reached during business hours. When sending product into Horizon, please include your RMA number, a list of the included items, and a brief summary of the problem. A copy of your original sales receipt must be included for warranty consideration. Be sure your name, address, and RMA number are clearly written on the outside of the shipping carton.

NOTICE: Do not ship LiPo batteries to Horizon. If you have any issue with a LiPo battery, please contact the appropriate Horizon Product Support office.

Warranty Requirements

For Warranty consideration, you must include your original sales receipt verifying the proof-of-purchase date. Provided warranty conditions have been met, your Product will be serviced or replaced free of charge. Service or replacement decisions are at the sole discretion of Horizon.

Non-Warranty Service

Should your service not be covered by warranty, service will be completed and payment will be required without notification or estimate of the expense unless the expense exceeds 50% of the retail purchase cost. By submitting the item for service you are agreeing to payment of the service without notification. Service estimates are available upon request. You must include this request with your item submitted for service. Non-warranty service estimates will be billed a minimum of ½ hour of labor. In addition you will be billed for return freight. Horizon accepts money orders and cashier's checks, as well as Visa, MasterCard, American Express, and Discover cards. By submitting any item to Horizon for service, you are agreeing to Horizon's Terms and Conditions found on our website Horizon Hobby Service Center.

NOTICE: Horizon service is limited to Product compliant in the country of use and ownership. If non-compliant product is received by Horizon for service, it will be returned unserviced at the sole expense of the purchaser.

Warranty, Service and Customer Service Contact Information

Country of Purchase	Horizon Hobby	Address	Phone Number/Email Address
United States of America	Horizon Service Center (Electronics and engines)	4105 Fieldstone Rd Champaign, Illinois 61822 USA	877-504-0233 Online Repair Request: visit www.horizonhobby.com/service
	Horizon Product Support (All other products)	4105 Fieldstone Rd Champaign, Illinois 61822 USA	877-504-0233 productsupport@horizonhobby.com
	Sales Customer Service	4105 Fieldstone Rd Champaign, Illinois 61822 USA	(800) 338-4639 sales@horizonhobby.com
United Kingdom	Horizon Hobby Limited	Units 1-4 Ployters Rd Staple Tye Harlow, Essex CM18 7NS United Kingdom	+44 (0) 1279 641 097 sales@horizonhobby.co.uk
Germany	Horizon Technischer Service ——— Horizon Hobby GmbH	Christian-Junge-Straße 1 25337 Elmshorn Germany	+49 (0) 4121 2655 100 service@horizonhobby.de
France	Horizon Hobby SAS	11 Rue Georges Charpak 77127 Lieusaint, France	+33 (0) 1 60 18 34 90 infofrance@horizonhobby.com
China	Horizon Hobby China	Room 506, No. 97 Changshou Rd. Shanghai, China 200060	+86 (021) 5180 9868 info@horizonhobby.com.cn www.horizonhobby.com.cn

FCC Information

This device complies with part 15 of the FCC rules. Operation is subject to the following two conditions: (1) This device may not cause harmful interference, and (2) this device must accept any interference received, including interference that may cause undesired operation.



CAUTION: Changes or modifications not expressly approved by the party responsible for compliance could void the user's authority to operate the equipment.

This product contains a radio transmitter with wireless technology which has been tested and found to be compliant with the applicable regulations governing a radio transmitter in the 2.400GHz to 2.4835GHz frequency range.

Compliance Information for the European Union

Declaration of Conformity

(in accordance with ISO/IEC 17050-1)
No. HH2012092702

Product(s): SPM DSMX 6Ch AS3X Receiver
Item Number(s): SPMAR635

Equipment class: 1

The objects of declaration described above are in conformity with the requirements of the specifications listed below, following the provisions of the European R&TTE directive 1999/5/EC:

EN 301 489-1 V1.7.1: 2006

EN 301 489-17 V1.3.2: 2008



Signed for and on behalf of:
Horizon Hobby, Inc.
Champaign, IL USA
September. 27, 2012

Steven A. Hall
Executive Vice President and Chief Operating Officer
International Operations and Risk Management
Horizon Hobby, Inc.



Instructions for disposal of WEEE by users in the European Union

This product must not be disposed of with other waste. Instead, it is the user's responsibility to dispose of their waste equipment by handing it over to a designated collections point for the recycling of waste electrical and electronic equipment. The separate collection and recycling of your waste equipment at the time of disposal will help to conserve natural resources and ensure that it is recycled in a manner that protects human health and the environment. For more information about where you can drop off your waste equipment for recycling, please contact your local city office, your household waste disposal service or where you purchased the product.



SPEKTRUM®

© 2012 Horizon Hobby, Inc.

AS3X, DSM2, DSMX, JR, SmartSafe and the Horizon Hobby logo are trademarks or registered trademarks of Horizon Hobby, Inc.

The Spektrum trademark is used with permission of Bachmann Industries.

Created 10/12 37268