

STEP 5.

傳動套管粘著於木塊凹槽內
Using epoxy to glue plastic tube on the block.

A.B膠粘著連杆頭
Using epoxy to glue push rod into adjustable clevis.

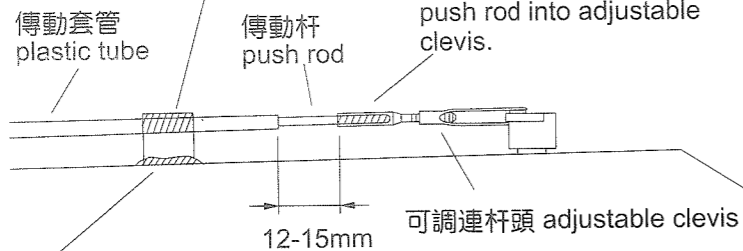

刮粗浮筒表面，再以AB膠將木塊固定。
Roughing the surface of the floats and glue block on it.

浮筒水舵裝配圖
assembling water rudder

水舵
water rudder

切除陰影部分之包覆紙，將木塊與傳動套管，以AB膠粘合於機身。
Cut off the covering of the marking area and glue block with tube on fuselage.

機尾方向舵連動裝配圖
connecting air rudder to the tiller arm on the water rudder

A.B膠粘著連杆頭
Using epoxy to glue push rod into adjustable clevis.

方向舵
Rudder

方向舵角控制片
control horn

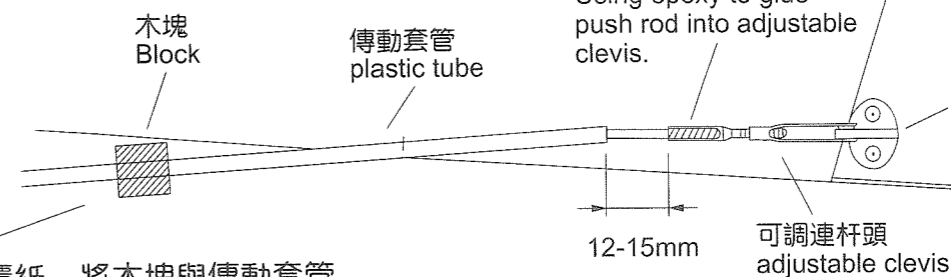

組裝完成圖
Assembly completed drawing

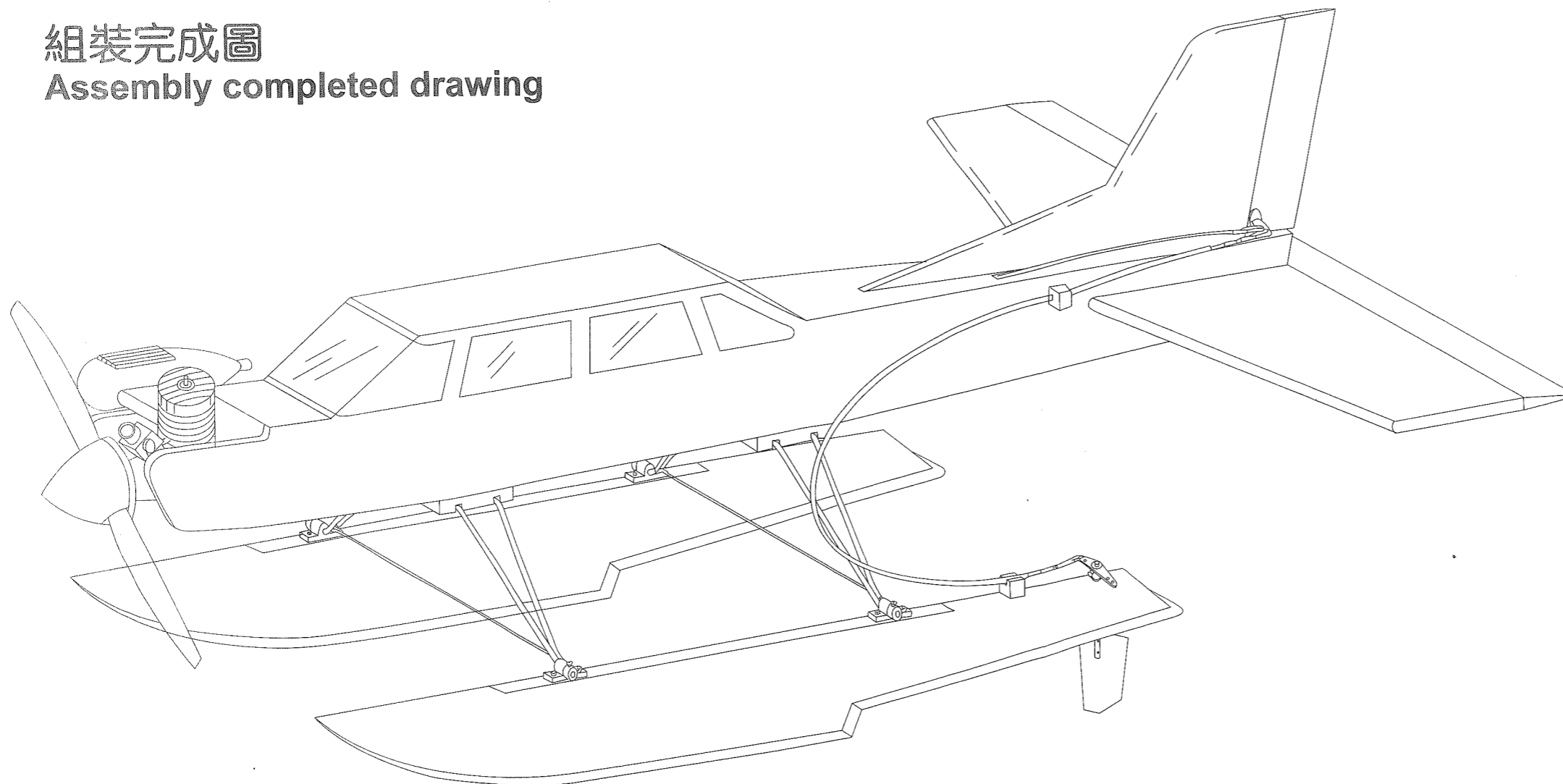

- | |
|--|
| 1. 浮筒 (左) float(left) x 1 piece |
| 2. 浮筒 (右) float(right) x 1 piece |
| 3. 轉向臂 servo arm x 1 piece |
| 4. 塑膠承座 plastic stand x 4 pieces |
| 5. 輪檔 collars x 4 pieces |
| 6. 可調金屬連杆頭 adjustable clevis x 2 sets |
| 7. 舵 water rudder x 1 piece |
| 8. 舵軸 tiller arm x 1 piece |
| 9. 輪架壓板 plate x 8 pieces |
| 10. 腳架木座 fixing block x 2 pieces |
| 11. 傳動套管固定木塊 block for push rod x 2 pieces |
| 12. 傳動套管組 plastic tube x 1 set |
| 13. 腳架 landing gear x 2 pieces |
| 14. 腳架橫拉杆 wire x 2 pieces |
| 15. 十字螺絲 screw M3 x 6 x 5 pieces |
| 16. 十字螺絲 screw M2 x 12 x 2 pieces |
| 17. 木工螺絲 tapping screw $\phi 2.6 \times 12 \times 16$ pieces |
| 18. 木工螺絲 tapping screw $\phi 3 \times 25 \times 8$ pieces |
| 19. 說明書 manual x 1 piece |

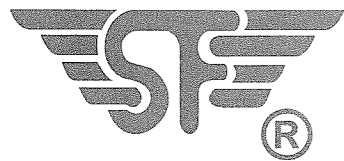

www.mth.com.tw

SUPER FLYING MODEL



40級浮筒組裝說明書 INSTRUCTION FOR .40-.46 FLOATS

STEP1.

加裝浮筒的飛行重心點，應相當於原飛機的重心點，以免影響飛行性能。
The C.G. point for assembling floats is the same C.G. point of the plane for not affecting the flying performance.

STEP2.

浮筒與機身水平推力綫之夾角的0至-2度。
The angle between floats and the centerline of the plane should be 0 degree to -2 degree.

STEP3.

浮筒組與機身可用膠帶暫時固定，以方便量測重心點，然後用筆畫出木塊粘合之邊綫。
Fixing float on fuselage by tape temporary for measuring the C.G. point Using pencil or marking pen to mark the outline of the fixing blocks.

STEP4.

切除機身底部陰影部分之包覆紙，以AB膠粘合脚架座木塊。
Cut off the covering of the marking areas on the bottom of fuselage and glue the fixing blocks on the marking areas.

STEP5.

刮粗浮筒表面，再以AB膠將木塊固定。
Roughing the surface of the floats and glue block on it.

STEP6.

套件附上之木塊，在完成組裝之後，可自行塗上防水油漆，顏色隨機體顏色塗裝。
The blocks included in the kit can be painted any color of waterproof paint to match the scheme of the plane.

NOTE

1. 木攻螺絲栓入之前，請先使用鑽頭引孔，如 $\varnothing 2.0$ 鑽孔 $\varnothing 2.6$ 螺絲， $\varnothing 2.5$ 鑽孔 $\varnothing 3.0$ 螺絲。
Please drill adequate holes before screwing the tapping screws such as: drill hole $\varnothing 2.0$ for $\varnothing 2.6$ screw; hole $\varnothing 2.5$ for $\varnothing 3.0$ screw.
2. 建議使用硬化時間5-30分鐘A.B.膠。
It is better to use 5-30 min. epoxy.

