

## STEP 27: Compass and Quarterdeck Galleries

Assemble the binnacle compass housing using plywood parts P.15 and wooden block 6x13x27 - see **Fig.32**. Fix in place in front of the wheelhouse group on the quarterdeck.

**Photo.29** and **Fig.33** show the quarterdeck galleries to be assembled from plywood parts n.57, Walnut plank and ladder items. Drill  $\varnothing 0.8$  holes for the handrails and make the handrails from  $\varnothing 0.8$  brass wire.

*Tip: To straighten the brass wire, grip one end in a table vice and pull the other end with a pair of pliers to stretch the wire slightly.*

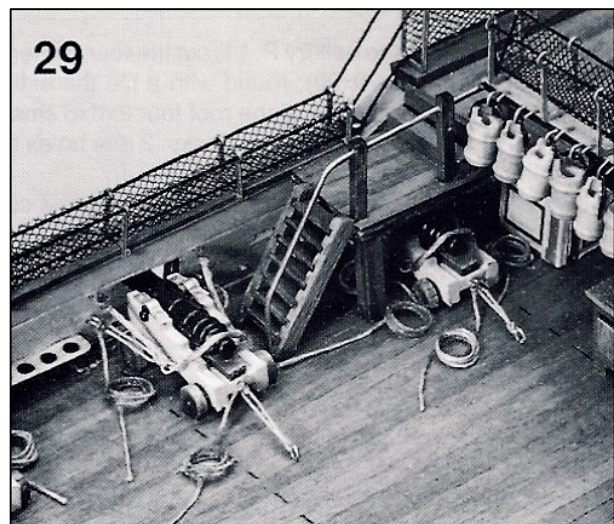
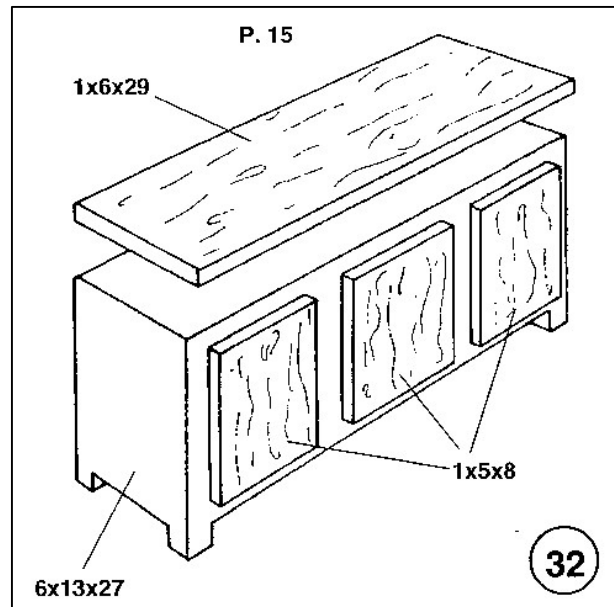
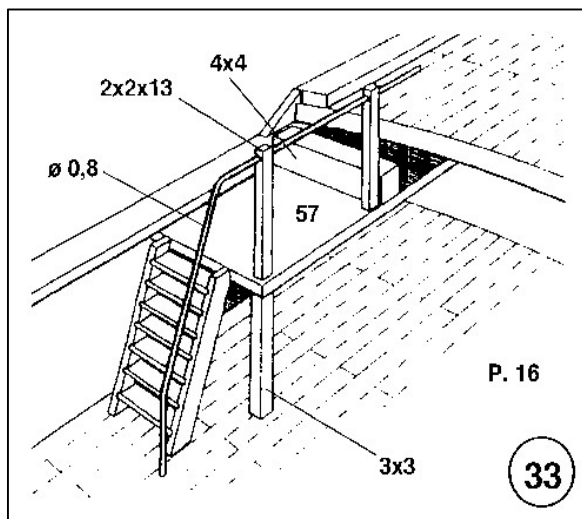

## STEP 28: Companionway

**Fig.34** shows the companionway on the quarterdeck: Part. 17. The small waist opening is framed with 0.5x3 Walnut planks. Glue on the four corners of the waist the four walnut stanchions (4x12 mm) and fit the handrail made from 1.5x3 Walnut plank. Assemble the ladder and glue it between the quarterdeck and upper gundeck as shown.

**Fig.35** shows the construction of the quarterdeck bits and grating assembly: Part 18. Take the dimensions from **Plan 4** and make part P.18 as shown. Assemble parts n. 58 (main bits) on the base as shown in **Fig.35**.

**Fig.36** shows the quarterdeck banisters using parts P.19. Cut five 7mm cubes from 3x3 Walnut to finish the structure as shown in **Fig.36**. Drill  $\varnothing 1$  holes in the upper strip and fix the brass ball-stanchions C with instant glue.

Insert through the upper balls the black  $\varnothing 0.5$  rope and fix the hammock netting with some drops of instant glue using the method described previously. Fit fourteen eyelets on the wheelhouse transom as hooks to hold the fire-buckets (see **Fig.36**). Glue on the bulwarks the ball-racks n.59 and n.60 for the cannons and fit the belaying-pin racks n.61 and n.62 in place.

**Photo.29A** below shows the quarterdeck with these parts fitted.

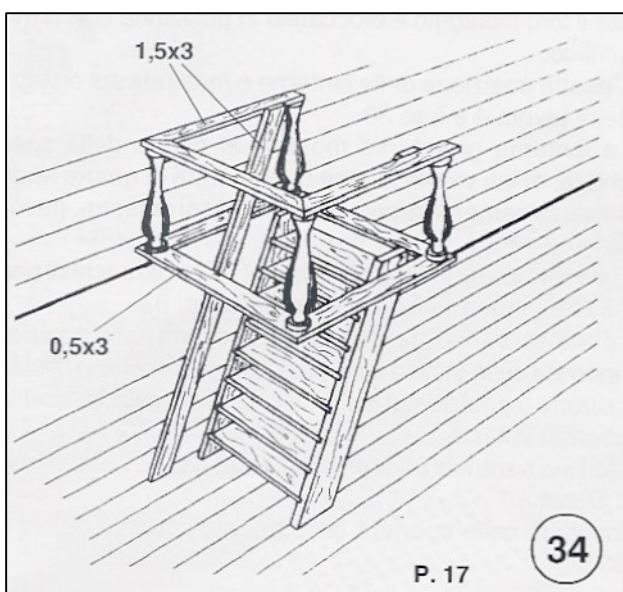

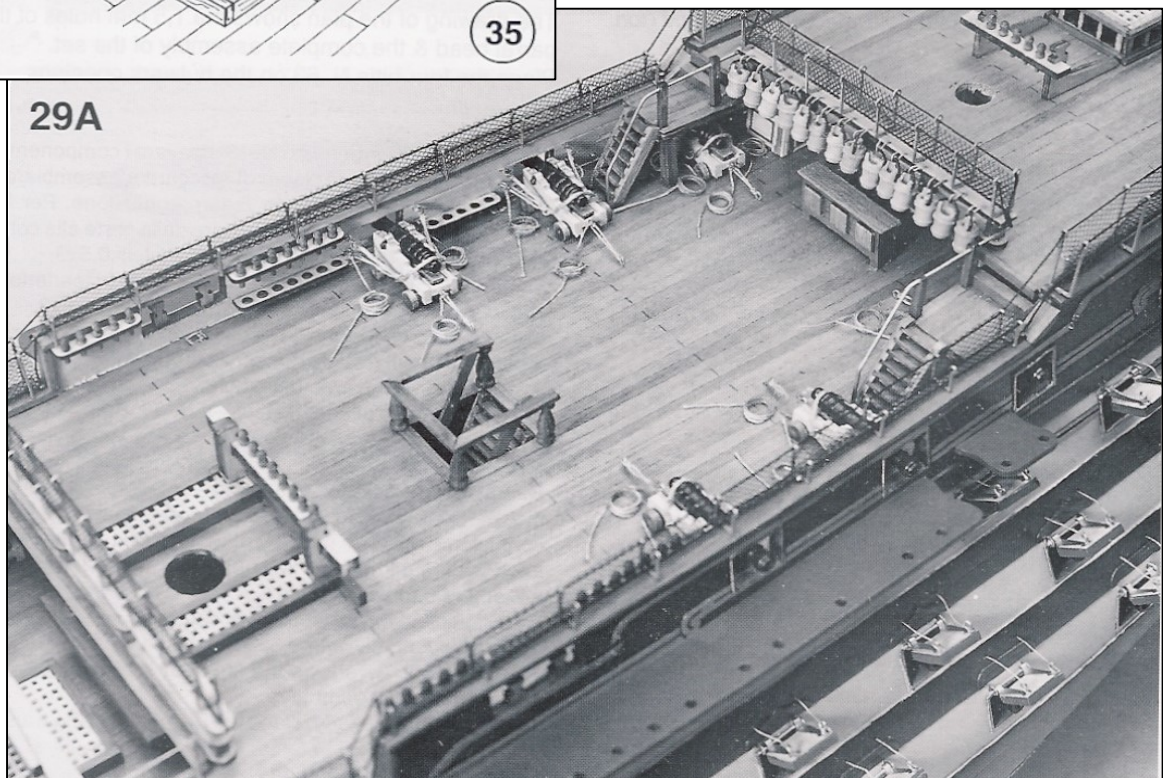
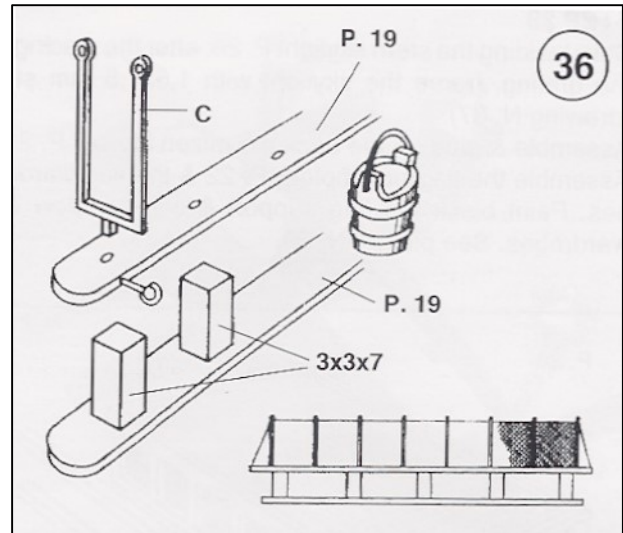
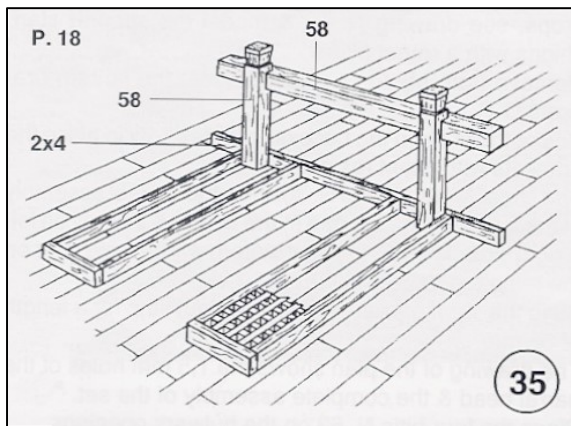

### STEP 29: Stern Skylight and Flag Lockers

**Fig.37** shows the construction of the stern skylight P. 20. Make the grating and frame it with 1.5x1.5 Walnut planks as shown. Place the completed skylight on the poop deck as shown in **Plan 4**.

**Fig.38:** Assemble and glue on the deck the mizzen fife rail P.21.

Assemble the flag pole holder P.22 and the two flag lockers on the stern. Paint the flag support black and the lockers yellow ochre.

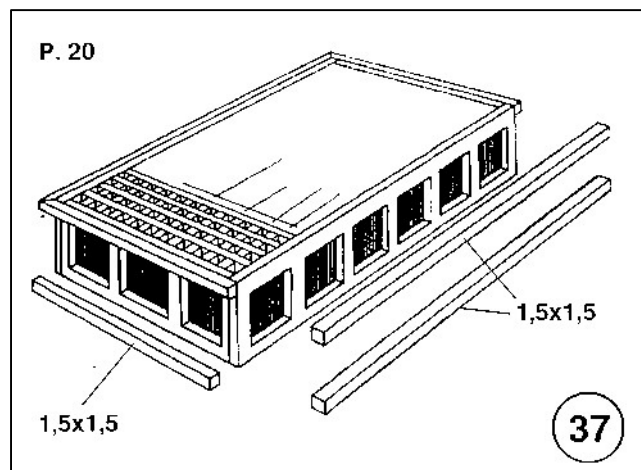

### STEP 30: Stern Lanterns

Assemble the four lanterns P. 23 with small drops of instant glue. See **Fig.38**. Form the support stanchions into shape with round pliers. Remove lantern brackets O-P from the photo-etched brass sheet. Drill holes in the stern and fix the brackets in place with instant glue. **Plan 4** and **Photo.30** show the correct assembly of the lanterns: the large one in the centre and two 2 small lanterns on left and right sides. The fourth small lantern will be fixed later on the mainmast top (Plan5).

Make the stern parrels from 4x4 walnut strip 33 long. Shape the ends of the parrels into short tenons and insert them into holes drilled into the stern transom photo-etched plate either side of the flag-and-lily emblem, as shown on the box cover. Set the parrels parallel to each other and to the keel. Paint them black.

Fix the four bitts n. 63 on the bulwark openings.

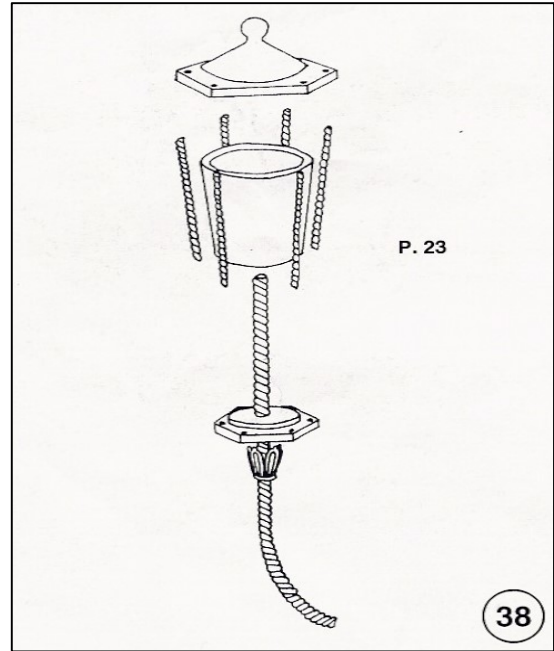

### STEP 31: Lifeboats

Assemble the frames and keels of the lifeboats from the parts on plywood sheet Tavola 13. Plank the lifeboats with the first upper planks of 1x4 Walnut and then use 0.5x3 planks for the rest of the hulls. Sand the first planking layer and apply a second layer of 0.5x3 planks. **Photo.31** shows the skeletons of four lifeboats and four built up bodies. Paint the lifeboats as shown in the colour illustration on the kit's box. When complete, stack the lifeboats on the lifeboat supports above the upper gun deck and lash them to the supports with medium rope.

Glue on the hull sides the anchor slipway timbers n. 64 – see **Photo.32**.

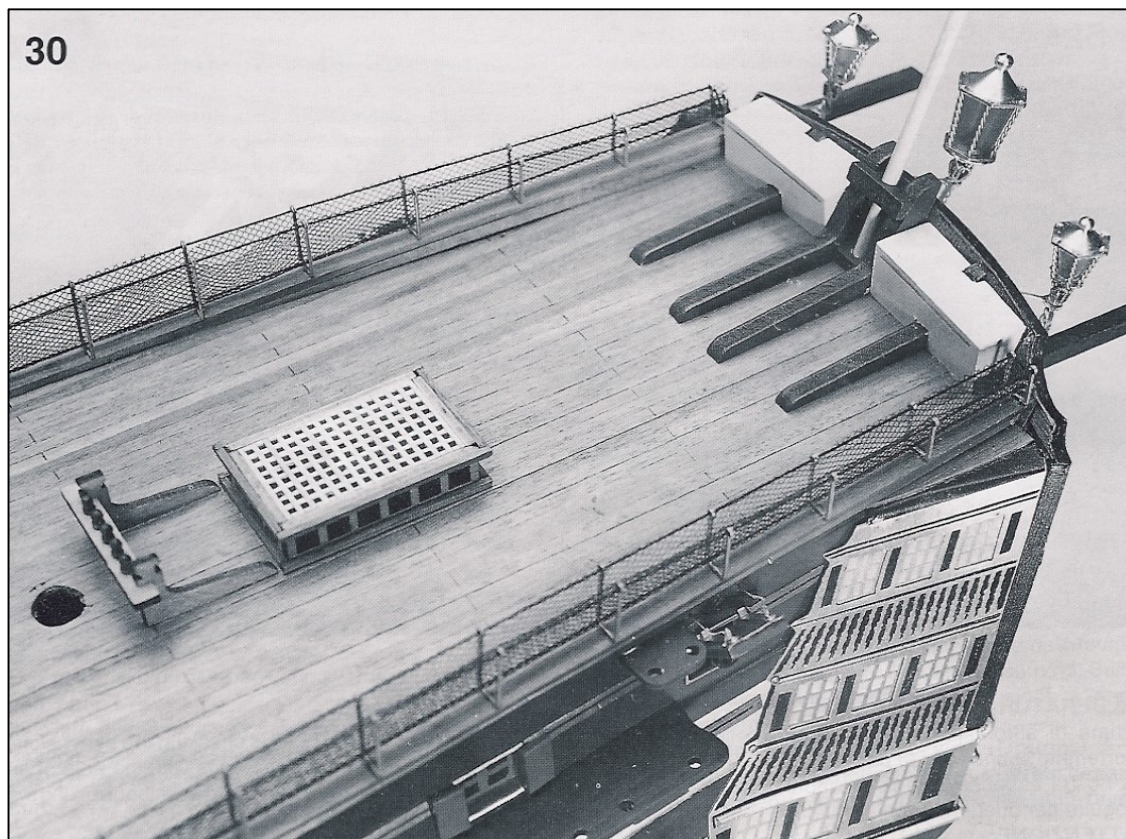

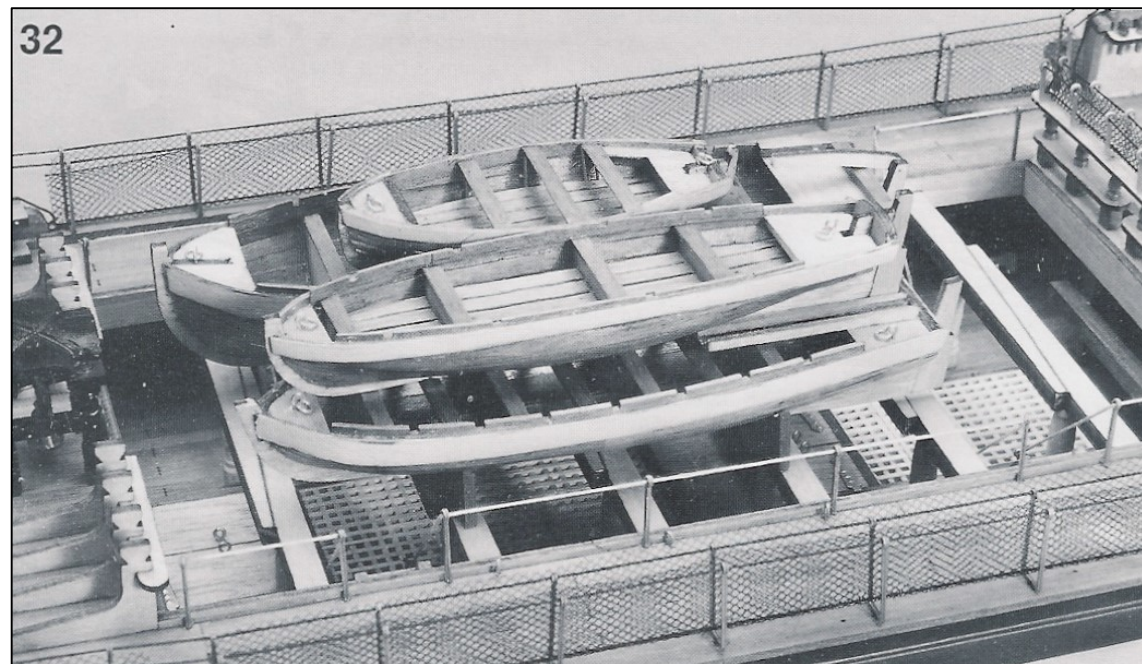
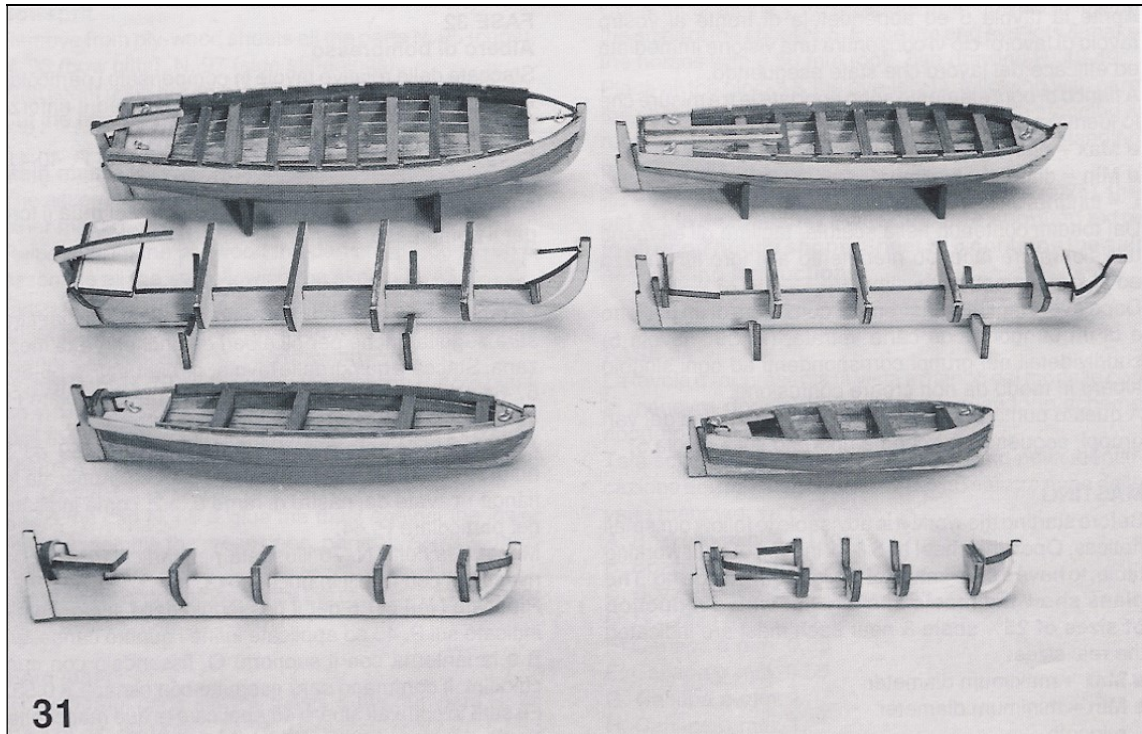

### STEP 32: Cutting and Shaping Masts and Spars

Taking the measurements from the notes on **Plan number 5**, cut and shape the dowels to make the various masts and spars for the *Victory*. We advise you to proceed carefully and to “measure twice and cut once” to avoid errors and wastage. The plan shows the masts and spars at **75% of scale size**. The real dimensions are given near to each mast on the plan and these identify the cutting and tapering dimensions as follows: **L** = the finished length; **ØMax** = the maximum diameter; **ØMin** = the minimum diameter at the ends.

Unless shown otherwise, taper the dowels towards one end only. Where indicated, taper the dowels using either i) a hand plane and sandpaper, or ii) an electric drill and sandpaper, or preferably, iii) an electric lathe (such as Mantua Model **Art. 8160**). For the yards, start the tapering 75mm from the ends, leaving the centre section unaltered. Finish the masts and spars with fine grit sandpaper and varnish with two coats of matt varnish, sanding lightly between coats. When assembly has been completed, paint the masts yellow ochre and black as per the colour illustration on the kit's box.

Temporarily label the masts and spars with masking tape until assembled.

## STEP 33: Fitting the Bowsprit

Assemble parts n.95 (caps), n.96 (bow bits), n. 97 (side stiffeners) and glue with instant resin as shown on **Plan 5** in the detail drawings **P.40, 41, 42** and **44**. Cut the bowsprit opening in the bow deck.

## STEP 34: Assembling the Masts

### Mainmast

The assembly of the mainmast (the central mast) is the same process as used for the other two masts.

- Shape the lower mainmast end following the sketch **P.43** on **Plan 5**. Fix to the mast the side stiffeners n.69 and the front stiffener made from 1.5x3 plank. Assemble the flanges, cut from 0.3x2 copper strip, and see drawing **P.44**.
- Glue both cheeks n.66 to the mast sides. Glue the trestle trees n.67 in place on the support cheeks and fit the cross trees n.68 into the trestle tree slots. See **P.43**.
- Build the *top* n.70 as shown on the drawing **P.45** and plank the platform on the upper side with 0.5x3 Walnut strips and fit 1x2 Walnut foot treads. Drill  $\varnothing 1.5$  holes in the *top* for the shrouds, insert the four stanchions B and the brass rail, and fix the lantern on its support Q, nailing the support in place. Glue the *top* on the cross trees.
- Insert the mast cap n.65 and glue the topmast against the front cross tree. Fit the mast bracer A made from dowels between the *top* and the cap as shown on **Plan 5**.
- Assemble the trestle trees n.72 and the cross trees n.73 to the upper mast and drill  $\varnothing 1$  holes in the cross trees as shown in **P. 46**. Fit the mast cap and secure the topgallant mast in place as shown.
- Drill the mast end and fit the brass finial in place.

### Foremast

Refer to the drawing on **Plan 5** of the foremast (the mast at the front of the ship) giving the part numbers for the foremast elements and follow the process described above for the mainmast.

### Mizzen mast

Refer to the drawing on **Plan 5** of the mizzenmast (the mast at the stern of the ship) giving the part numbers for the mizzenmast elements and follow the process described above for the mainmast.

The assembly of the jaws to the mizzen gaff and mizzen boom is shown in drawing **P. 47**.

### Other items

- Make and fit the mainmast studdingsail outrigger booms to the sides of the hull as shown on **Plan 4** and **Plan 7 / P.65**.
- Trial-fit the masts into the deck, checking the alignment and using small wedges as necessary to get a perfect alignment. Slide a mast foot (n.74-84-94 respectively) up each mast base then glue the base and insert the mast into the deck, pressing the foot down on the deck.
- Fit the flagpole into the holder on the stern.
- Fit yard fenders on the yards made from 0.5x3 plank as shown in **Plan 5** and **P.42**. Fit the yardarm eyelets in the end of the yards and lash the yardarms in place with  $\varnothing 0.50$  rope, see **P.48** and **P.49**. Fit the footrope stanchions **P.48** to the yards and rig the footropes using  $\varnothing 0.50$  rope. Seal the knots with instant glue.
- Fit the eyelets D to the masts. Fit all the rigging blocks to the masts and yards separately, following the rigging details on **Plan 7** with care.

## STEP 35: Standing Rigging

**Plan 6** shows the side view of the model with standing and running rigging. The key block on the left side of the plan identifies the block and rope sizes as follows:

|                      |                      |                      |
|----------------------|----------------------|----------------------|
| A: Single 3 mm block | B: Single 5 mm block | C: Double 5 mm block |
| D: 3 eye 7 mm block  | E: 0,25 mm rope      | F: 0,50 mm rope      |
| G: 1 mm rope         | H: 1,25 mm rope      |                      |

On the top of the sheet the rigging plan is illustrated with the belaying (termination) points identified. The rigging numbering refers to these termination points.

*Note: All knots should be secured with drops of instant glue to avoid loosening. The ends of the rope should be hardened with some instant glue for better insertion into the small holes of the blocks and deadeyes.*

We will start from the standing rigging shown on **Plan 6** (unnumbered), and which is also shown in the detailed drawings P.50, 51, 52, 53, 54, and 55. The plan shows the masts at **75% of scale size**

**P.50.** This shows a chain plate and a pair of deadeyes with the  $\varnothing 0.25$  rope lanyard linking the two deadeyes. **Photo.33** shows how to make the strops and the rings to fit. The chainplates pass through the channels and the link plates are nailed and glued to the hull.

**P.51.** The assembly of the shrouds H is made by connecting the upper deadeye to the  $\varnothing 1$  shroud rope and securing the shroud rope around the mast as shown on drawings **P.51** and **P.52**.

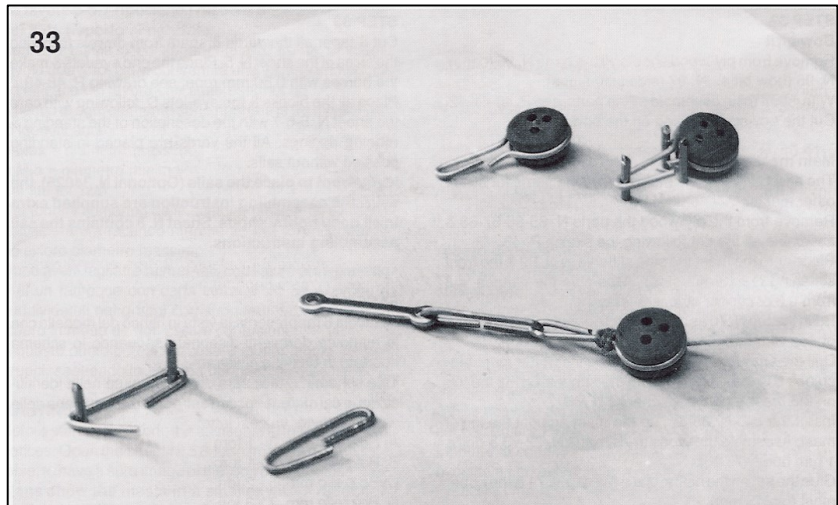

The lower shrouds feed through the *top* openings as illustrated in sketch **P.52**.

For a correct tensioning of the shrouds, tie one rope on each side and check the perpendicularity of the masts. Adjust the tension as necessary

Now assemble the middle shrouds as done for the lower shrouds and use 5 mm deadeyes B and  $\varnothing 1$  rope. Details of the fixings to the mast are shown in **P. 53**. The distances of the deadeyes to the top are: fore 34 mm, main 36 mm, and mizzen 32 mm.

**P.53** also shows how to rig the upper shroud lines to the middle shroud lines and shows the rigging of the upper shrouds from the mast through the cross trees to the shrouds. Use  $\varnothing 0.50$  rope.

To align the shrouds fit a 1.5x1.5 plank on each shroud run as shown on the drawing **P. 52**.

To finish the shrouds we have to tie the ratlines, made with 0,25 mm rope.

**P. 54** shows how to rig the ratlines, set at 5mm intervals on the shrouds.

**P.55** shows the starting point of the mainstays, made from  $\varnothing 1.25$  rope. The riggings go up through the *top* holes and down to the bowsprit via 7mm blocks.

The fore and main stays are made with double rope and lashed together with thin rope as shown in **Plan 6**. The mizzen stays are single and are made fast on the pair of eyelets in the main mast.

Place all the other standing rigging following Plan 6.

## **STEP 36: Rigging the Yards to the Masts**

Before starting with the numbered running riggings it is advisable to fasten the yards to the masts in the positions indicated on **Plan 7**. Careful! The plan shows the masts and spars at **75% of scale size**.

**P. 56** shows the parrels numbered 13, 14, 15, 16, 21 and 22. Sketch **P. 57** shows the upper yard parrels. The tensioning ropes will be made fast to the belaying pin racks.

## **STEP 37: Running Rigging**

The running riggings are fastened to the deck belaying pins as shown in sketch **P.58**, at the points marked on the termination drawing on **Plan 6**.

**P. 59** shows the lifts riggings numbered 13, 14 etc. **P. 60** shows the brace riggings numbered 17 and 18 etc. from the stays. **P. 62** shows the building of the fore and main parrels.

**P. 61** shows the flag assembly and their riggings; the flags are fixed with small glue drops. To give the appearance of weight in a windless condition, fix each sail with small pins in the drooped state as shown on the kit's box and spray with hair lacquer to hold the flag in position.

**P.62** shows how the lower yard on the main mast is braced.

### **STEP 38: Davits**

Cut from 3x3 Walnut strip the four arms of the life boat davits. Build the stiffeners A from 0.5x2.5 brass sheet; drill  $\varnothing 1$  holes for the pins C ( $\varnothing 1$  brass wire), and fix the eyelets B. See drawing **P.64**. Make the riggings with  $\varnothing 0.75$  rope as shown in the side view on **Plan 4**.

**P.65**. Outrigger supports are included on the photo-etched brass sheet. Remove these parts S with a pair of scissors and fix the supports on the fore and main channels with instant glue. Place the hook A ( $\varnothing 1$  brass wire) into a hole drilled into the dowel ends.

### **STEP 39: Anchor Assembly**

Place the anchor supports P.24 (Plan 4) cut from 2x8 plank and with a small 8x8x13 block. See **P.66**.

Fit the hawse hole plates to the bow as shown on **Plan 4** and drill holes to take the anchor ropes.

Shape the anchor stocks with a file, paint the stocks black and tie  $\varnothing 0.75$  rope in four places as illustrated in the drawing **P.67**. Place the stocks on the anchors and fit the upper ring. Tie the anchors with  $\varnothing 0.75$  rope following the rigging of the drawing **P.42**. Feed the ropes through the hawseholes and secure with glue

### **SAILS**

If you wish to fit sails, an optional sail set with assembling instructions Art. 34025 is available through all good hobby shops. Plan 8 contains the sail assembly details.

----- ooOOoo -----

# Assembly Instructions: Victory Art. 738

## Material list of the kit

|  |  |
|--|--|
| Board N. 1 white poplar plywood 5x195x600 mm | N. 2-10-11   |
| Board N. 2 white poplar plywood 5x220x590 mm | N. 3-8-9   |
| Board N. 3 white poplar plywood 5x220x750 mm | N. 4-5-6-7   |
| Board N. 4 white poplar plywood 5x170x535 mm | N. 1-12-13-20-21   |
| Board N. 5 white poplar plywood 5x170x840 mm | N. 15-16-18-19   |
| Board N. 6 walnut plywood 6x245x910 mm       | N. 14-25-31-65-75-85 - rudder - anchor stock                                 |
| Board N. 7 walnut plywood 1,2x175x625 mm     | N. 26-29-30-41-56-59-60-61-62-P20  |
| Board N. 8 walnut plywood 1,2x160x660 mm     | N. 27-28-33-34   |
| Board N. 9 walnut plywood 1,2x175x300 mm     | N. 24-32-44-66-69-76-79-86-89-98-P10-P12-P19-P22                             |
| Board N. 10 walnut plywood 2x165x420 mm      | N. 22-43-47-48-49-50-51-52-53-P1-P5-P13                                      |
| Board N. 11 walnut plywood 4x145x285 mm      | N. 35-36-37-38-39-40-42-54-55-58-64-71-81-91-95-P22                          |
| Board N. 12 walnut plywood 2x135x510 mm      | N. 45-46-57-67-68-70-72-73-77-78-80-82-83-87-88-90-92-93-96-97-P3-P4-P12-P21 |
| Board N. 13 walnut plywood 2x120x275 mm      | N. 63-74-84-94 - 4 life-boats.   |

| Lime wood strips                   | Walnut strips                      | Dowels                          |
|------------------------------------|------------------------------------|---------------------------------|
| 100 1,5x6x900 mm                   | 170 0,5x3x500 mm      1 2x2x400 mm | 1 ø 2x610 mm      1 ø 6x300 mm  |
|                                    | 6 1x2x600 mm      3 2x4x500 mm     | 1 ø 3x490 mm      1 ø 6x500 mm  |
| <b>White poplar plywood strips</b> | 2 1x3x400 mm      5 2x6x500 mm     | 1 ø 3x550 mm      1 ø 6x610 mm  |
| 6 5x10x720 mm                      | 2 1x4x600 mm      2 2x10x600 mm    | 1 ø 3x610 mm      1 ø 8x300 mm  |
| <b>Walnut profile</b>              | 100 1x6x900 mm      1 3x3x500 mm   | 2 ø 4x430 mm      2 ø 8x410 mm  |
| 2 4x4x600 mm                       | 1 1,5x1,5x500 mm      2 4x4x500 mm | 1 ø 4x540 mm      1 ø 10x640 mm |
|                                    | 9 1,5x3x500 mm      1 6x6x700 mm   | 3 ø 5x500 mm      1 ø 12x450 mm |
|                                    | 12 1,5x4x900 mm      1 8x8x500 mm  |                                 |
|                                    | 4 1,5x6x900 mm                     |                                 |

### FITTINGS

- Flag pack.**
- 1 Set flags
- ø 0,50 mm rope pack.**
- 1 Rope ø mm. 0,50x100 mt.
- ø 1 mm rope pack.**
- 1 Rope ø mm. 1x100 mt.
- ø 0,25 mm rope pack.**
- 1 Rope ø mm. 0,25x100 mt.
- 1 Rope ø mm. 0,50x10 mt.
- 1 Rope ø mm. 1,75x3,5 mt.
- ø 5 mm dead-eyes pack.**
- 100 Walnut dead-eyes ø 5 mm
- ø 7 mm dead-eyes pack.**
- 112 Walnut dead-eyes ø 7 mm
- 2 nail packs.**
- 300 Nails 10 mm
- Net pack.**
- 1 Black net 300x350 mm
- Steering wheel**
- 2 Steering wheel ø 20 mm
- 1 Spacer ø 6x8 mm
- 1 Pin ø 2x21 mm
- Bucket pack.**
- 14 Box - wood bucket ø 5x7 mm
- Stanchion pack.**
- 14 Box - wood stanchions 5x26 mm
- Ladder pack.**
- 7 Right ladder sides 2x3x34 mm
- 7 Left ladder sides 2x3x34 mm
- 2 Lime wood strips 5x5x65 mm
- Port frames pack.**
- 106 Port frames
- Grating pack.**
- 130 15 step gratings
- 3 mm block - 1 eye - pack.**
- 70 Walnut blocks 3 mm - 1 eye
- 5 mm block - 1 eye - pack.**
- 70 Walnut blocks 5 mm - 1 eye

### Belaying-pin pack.

- 46 Walnut belaying-pin 8 mm
- 4 Walnut stanchions 12 mm
- 8 Walnut stanchions 6 mm
- 7 mm block - 3 eyes - pack.**
- 28 Walnut blocks 7 mm - 3 eyes
- 11 Walnut blocks 5 mm - 2 eyes
- Wheel pack.**
- 36 Walnut wheel art. 30540
- Dummy barrel pack.**
- 84 Dummy barrels 30 mm
- Bell pack.**
- 4 Square stanchions 4x4 mm
- 2 Walnut half dowels ø 17x22 mm
- 1 Bell art. 32390
- 1 Walnut block 5x20x20 mm
- 1 Walnut block 6x13x27 mm
- Anchor pack.**
- 4 Anchors 65 mm
- 4 Brass rings ø 8 mm
- Wire pack.**
- 1 Brass wire ø 0,8x7000 mm
- 1 Copper strip 0,5x2x1200 mm
- Port hinge pack.**
- 160 Brass port hinges
- Drip-moulding pack.**
- 32 Plane drip-moulding
- 28 Pagoda drip-moulding
- Clamps pack.**
- 64 Clamps
- 160 Pintles
- Gun pack.**
- 18 Barrels 30 mm
- 18 Brass pins ø 1,5x11 mm
- 2 Carronade 27 mm
- Art. 33050 eye-let pack.**
- 240 Eye-lets art. 33050
- 60 Eye-lets art. 33040
- 44 Brass eye-lets 25 mm

### Big lantern pack.

- 1 Rolled wire ø 1x110 mm
- 1 Rolled wire ø 2x50 mm
- 1 Cups
- 1 Rose
- 1 Medium base
- 1 Red large cone
- 1 Large cap

### Small lantern pack.

- 1 Rolled wire ø 1x290 mm
- 3 Rolled wire ø 2x50 mm
- 3 Cups
- 3 Small bases
- 3 Red small cones
- 3 Small caps

### Channel pack.

- 18 Channel support

### Chain pack.

- 10 Brass rings ø 3 mm
- 8 Hinges art. 37360
- 36 Triggers guards
- 1 Chain 500 mm
- 10 Rudder hinges
- 5 Pin rudder hinges
- 4 U supports falconet

### Photo etched sheet

- 1 Photo etched sheet 60x135 mm
- 1 Full cut etched sheet

### Photo etched sheet

- 1 Photo etched sheet 300x400 mm

### Copper plate pack.

- 3000 Copper plate

### Base moulding pack.

- 4 Walnut frames 18x22x110 mm

### Cast part tray

- 1 Casting set
- 2 Door walnut blocks 10x21x21 mm
- 1 Port mask
- 1 Mouldings 1,5x2,5x1000 mm
- 8 Plan sheets
- 1 Instruction book

*Mantua Model may from time-to-time, substitute the items above for those made of a different material, depending on the availability of supplies.*



## ADVICE ON PLANKING THE HULL

Newcomers to this fascinating hobby, or those new to the construction of a Mantua Group period ship model, sometimes have questions when they start to work such as: "How big an obstacle is the planking? Is it possible to have something additional in the way of equipment or instructions to help in this most important part? Are there any photographs or diagrams that may help?" To assist you, we have produced this short instruction sheet in an attempt to lessen any problems you may encounter.

## PLANKING OR THE APPLICATION OF STRIPS

First, a short note on the background. Each vessel was originally clad with large wooden boards positioned longitudinally or diagonally to the line of the hull, either with one plank overlapping the next (clinker-built), or planked one adjacent to the next (carvel-built), and nailed onto the ship's frames. This covering, in addition to being necessary for buoyancy (after caulking and sealing the joints) also gave considerable strength to the whole vessel.

In the case of our own models, because of the nature of the materials used, the planking will be accomplished using not short planks, but with full strips wherever possible, and doubled up in most cases, as they were in the original vessels. This technique is made possible through the flexibility and quality of the materials provided. To achieve a high quality finish to the planking, we suggest the following proven system, which is demonstrated in the diagrams on the last page.

The planking operation begins on plan number 1 of each of our model's instructions. The position of the first plank is shown on a profile of the skeleton structure after assembly. This reference point normally corresponds to the highest point of the two or three central frames and coincides with the lowest point of the curve formed by the extreme tops of the frames themselves. Where required, use a strip bender to curve the plank so that it fits the shape of the hull.

The first strip applied must be perfectly parallel to the line of the keel and should be fitted at the bow, the other end projecting beyond the length of the hull as in Fig.1 below. If the ship is to be double-planked, the initial planks may be glued and lightly pinned to the frames. The pins are to be removed once the assembly has properly set. Please note that where the upper sections of the frames are to be removed later, the planks should be pinned only at these places, i.e. no glue applied.

Proceed in the same manner from the top to bottom, fitting each plank snugly against the other, checking that they can be positioned easily without having to unduly force or twist the plank longitudinally. **Be sure to cover each side of the hull alternately, working three to four planks at a time. This avoids twisting the hull.**

After a number of these 'easy' planks have been fitted, a certain amount of difficulty will be encountered in placing subsequent strips, as the planks will now want to overlap in some places. You will now have arrived at the curve or sheer, of the vessel. Planking now requires a different procedure. All the planks must adhere to, and lie flat against, the frames for their entire width without curling, twisting or forming strange and unwanted 'ears'. We need to overlap the new plank on the previously positioned plank, allowing the strips to guide us in determining at what point the overlapping is to begin at each end. Position this overlapping plank without gluing onto the central two or three frames of the hull (see Fig.2), holding the ends down with your fingertips, mark both ends where they overlap, with a pencil. Cut along the lines drawn, using a sharp craft knife (see Fig.3).

Reposition the cut strip on the hull, fitting it snugly against the preceding plank, making slight adjustments to the angled cut as necessary, to ensure an exact fit. Now glue and pin the trimmed plank into position. Proceed with this method working towards the bottom of the hull i.e. towards the keel. Note that if this operation is carried out with due care, the planking will create the beauty of a wood inlay as the pieces fit together smoothly.

After proceeding in this manner for a while, we arrive at a point where the strips begin to leave a space (rather than overlapping). Irregular shaped spaces appear at the bow and stern ends

of the strips as we position them alongside the preceding strips. Even in this case, let the strip itself guide you. Fix the strip into position, letting it follow its own natural curve. The spaces that are left, normally acute triangles, will be filled later with segments of strip carefully cut to shape (see Fig.4).

After the lower portion of the hull has been completely covered, proceed to cover the upper areas along the upper deck parapets (if this is relevant to your model), leaving the ends of the strips extending beyond the parapet line. This will be trimmed away later to achieve the correct outline when measured against your drawings (see Fig. 5).

After the application of the first layer of planking over the entire hull, it will be necessary to smooth down the surface, removing the inevitable remains of excess glue, and leveling off any small imperfections in the planked surface.

*Having finished the surface to your satisfaction, if you are working on a kit that is double planked, proceed to apply the second and final layer of planking. This will be the layer that is visible. Having gained the skills carrying out the first level, you should now be well able to ensure that the quality of the second layer is of a high standard. The second planking will follow the same process, and, assuming a good level of preparation, should be somewhat easier.*

In some instances, strakes or rubbing boards that stand proud of the planking should be fitted to the first level of planking, where indicated on the drawings. However the instructions may well direct you to fit them after the second-level planking has been completed.

## **FINISHING**

When the final planking has been completed and the glue is fully set, the next task is to smooth the entire hull. We suggest the use of a scraper, a small wood plane (set fine) and various grades of sandpaper. At this point, after having trimmed off the excess planking, according to the general profile at the parapet line, proceed to install the handrails and the gunwales, fixed on the outside of the hull.

For the handrails, since they will be placed flat it will be necessary, especially at the bow and stern sections, to cut the strips into small angled (trapezoidal) sections in order to follow the curve of the hull (see Fig 6). The joints between these sections should be carefully sanded to make them as invisible as possible and to achieve a smooth, continuous curve.

For the gunwales, the strips will be fixed "edge on". The thickness of the strips (usually 2mm.) means that it will be necessary to pre-form them to fit the curves. We suggest the following methods to achieve the desired curve. i) If only a slight curve is required, use a standard plier-type plank bender. If a deeper curve is needed, ii) soak the strip in very hot water for a minute or two, then carefully bend and hold the strip in position against the hull or over an object of the right shape until set. Alternatively, iii) wet the strip and use a wheel-type bender. When the strip dries out it will be stabilized and can be placed into position. If a number of these are needed, build a jig to save time and increase accuracy.

At this stage, after ensuring the main decks are properly positioned, cut out the sections of the frames that are visible above the decks (extending up to the parapet tops), and smooth them off level with the deck surface. Proceed to plank the inside faces of the bulwarks, covering the inside of the first layer of white planks. Carefully smooth this planking using progressively finer grades of sandpaper.

*The foregoing briefly describes the subject of planking in an effort to assist the beginner with what appears to be a rather daunting task but which can become a very satisfying achievement. The rest "as they say" is up to you. Take your time; use your own skill and ingenuity to develop your own methods having considered our suggestions.*

----- ooOOoo -----

