

ASSEMBLY INSTRUCTIONS

General notes:

- All dimensions given are in millimetres. The symbol \varnothing means diameter
- Component numbers (n.11, etc) refer to the numbered plywood parts on the full-sized drawings of the twelve plywood panels labeled "Tavola 1" to "Tavola 12" on Plans 1, 2 and 3.
- Figure numbers given below (Fig.1, etc) refer to the numbered sketches on Plans 1 and 3, and in this guide.
- Photo numbers (Photo.1, etc) refer to the numbered photographs on Plan 3 and in this guide.
- Part numbers (Part 23 etc.) identified on Plan 4 refer out to the detailed or exploded drawings provided on Plans 5 to 8.
- The sequence given here is the recommended order for completing the model.

STEP 1: Preparing the Plywood Parts

On the twelve plywood panels supplied, and using the full-sized drawings on **Plans Number 1, 2 and 3** as guides, mark the identity numbers on the parts with a soft pencil - so that the marks may be erased later. Provide yourself with some storage boxes. Remove all of the plywood parts from the plywood sheets with a sharp craft knife, as shown in **Fig.1** on **Plan 1**, smoothing all edges with fine sandpaper and taking care not to destroy the laser-cut outline of each piece. Put the pieces in sets in the storage boxes for safekeeping.

It is essential to hold the keel steady in a vice or working cradle while the ship is being assembled. Keel-clamp **Mantua Model Art.8155** shown in **Photo.1** on **Plan 3** (not supplied) is ideal for this purpose. If you do not have a suitable keel clamp, make up a working cradle by nailing two runners cut from the scrap edges of plywood sheet Tavola 6, measuring 7x6x450 set 6 mm apart onto a wooden base (not supplied), so that the keel sits securely between the runners.

STEP 2: Assembling the Keel-and-frame Structure

Use the full-sized side view and **Photo.1** to **Photo.6** on **Plan 3** as guides. Place the keel n.14 in the keel clamp and trial-fit the frames into the keel without glue, filing the slots in the parts as necessary so that they slide together without being forced. **Warning: these parts are fragile and will fracture if forced.** As shown in **Photo.1** on **Plan 3**, first insert frames n.13 to n.5 into the keel, then insert the false deck plate n.15, checking that it is the right way round. Then slide frames n.4 to n.1 over n.15 inserting them into the keel in turn. Insert false deck-plate n.16 into the frames checking that it is the right way round, and push it fully home to align the frames. Clamp the structure together using rubber bands, clamps or pins, checking that the keel is not twisted and that the frames are aligned. Apply glue with a brush so that it runs into all the joints between the frames, false deck-plates and keel, as shown in **Photo.2** on **Plan 3**. Put the structure aside until the glue has set.

STEP 3: Tapering Frames and Fitting Dummy Cannon Barrel Supports

Frames n.1, 2, 3, 9, 10, 11 and 12 plus support plates n.22 and n.25 need to be tapered so that the hull planks make a smooth curve around the frames to the bow and to the stern respectively, and so that the area for adhesion is increased on these parts. Hold stern support plates n.22, bowdeck n.24 and bow support plates n.25 in place with clamps or tape. Using a 1x6 hull plank as a gauge, check how much material needs to be removed from the edges of these parts and shape the outside edges with a file as shown in **Fig. 2** on **Plan 3**.

Without glue and as shown in **Photo.4**, trial-fit the upper gundeck n.26 between the ribs n.4 to n.8, by gently squeezing the sides of the deck to curve the deck upwards, then positioning and releasing the deck. Make any adjustments that are necessary so that the deck sits snugly onto the frame tops. Trial-fit the maindeck n.29 without glue, as shown in **Photo.3**, making any adjustments that are necessary so that the deck sits snugly onto the frame tops. Clamp the bow end of the deck in place.

Insert the dummy cannon barrel supports (plywood strips 5x10x720) into the slots along the frames as shown in **Photo 5**, **Photo.6** and the side section on **Plan 3**. The full-length pieces for the middle and lower gundecks need to be curved at each end. Use strong miniature G-cramps to pull the plywood strips into the frames and achieve the required curvature. Brush glue into all the joints and allow to set. Paint matt black the top and side faces of the dummy cannon barrel supports between the frames.

STEP 4: Planking the Lower Gundeck

Remove the decks n.26 and n.28 from the structure. Apply glue to the tops of frames n.4 to n.8 and clamp the upper gundeck n.26 in place until set. Fit the bulkheads n.27 at either end of the deck.

Make up a deck-plank-cutting jig as shown in **Fig.3** on **Plan 3**, set to take 3mm-wide strips. Each deck plank is 80mm long with square-cut ends and is made from 0.5x3 Walnut plank. You will need approximately 150 planks to cover the upper gun deck. Plank the deck as shown in **Photo.4**, setting the plank joints alternately as shown in the centre drawing on **Plan 4**. Draw a centre-line down the deck using a pencil and a straightedge. Coat the deck to one side of the centre-line with a 10mm strip of glue using a brush, and place the first 0.5x3 Walnut planks along the centre-line, followed by two more planks alongside. Leave tiny gaps between the planks to simulate caulked joints. Continue across the deck from the centre to the sides laying about three planks at a time. Trim the planking around the holes in the deck, and fit shaped pieces of planking in the corners as necessary so as to cover the entire deck surface flush with the outside edges of the frames. When the deck covering is finished and dry, scrape the surface of the deck to remove excess glue and then smooth carefully with fine grade sandpaper. Varnish the deck with sanding sealer (such as Mantua Model Art.4401714, not supplied in the kit). Paint with matt yellow ochre acrylic paint the two bulkheads n.27 and the six ribs n.5 to n.7.

STEP 5: Assembling the Bow Deck and Stern Supports

Glue bow support plates n.25 and bowdeck n.24 in place on the bow (noting that parts n.25 are set at an angle to the keel when viewed from above and as positioned by deck n.24) as shown in **Photo.5**. Plank the bowdeck n.24 with 0.5x3 Walnut planks, smooth and varnish over. Glue parts n.17, 18, 19, 20, 21 and 22 onto the sterncastle as shown in **Photo.6**. Clamp until set. Fit the triangular strip n.23 under the bottom edge of frame n.13 as shown in the side view on **Plan 3**.

STEP 6: Fitting the Maindeck, Officers' Cabins and Wheelhouse Group

The maindeck n.28 comprises the quarterdeck and the forecastle deck. Glue the tops of the frames and fit deck n.28 in place, lining up the front of the deck with frame n.1 and holding the deck firmly down on the frames with clamps or pins until set. Insert a support made from 2x3 Walnut under the stern end of the deck as shown in **Plan 3**. Plank the deck with 0.5x3 Walnut planks using the method described previously, and varnish over. You will need approximately 250 planks for the maindeck. When the deck covering is finished and dry, scrape the surface of the deck to remove excess glue and then smooth carefully with fine grade sandpaper. Varnish the deck with sanding sealer.

Build the frame of the Officers' cabins with the five parts P.1 from plywood sheet Tavola 10. Assemble the cabins on the rear of the quarterdeck as shown in **Fig.4** opposite, noting that the deck slopes towards the bow and that the fronts of the cabins are glued onto the front face of frame n.10. Use 2x2 Walnut planks to support the corners of the frame.

From the photo-etched brass plate supplied, cut the cabin faces out with tin shears or strong scissors and finish the edges carefully with a file. Working on a flat work surface, paint the incised areas of the pieces with matt acrylic enamel paints: the windows light blue, the frames black and the panels yellow ochre. Do not worry about getting paint on the raised areas, as this will be removed later. When the paint is completely dry, lightly sand the surface of each piece with fine (600-grain) paper until the raised details become paint-free and polished, the paint remaining only in the incised portions. Coat the parts with matt varnish to keep the brass bright. Abrade the backs of the plates with sandpaper and fit them to the cabin frame with instant glue, as shown in **Fig.4** above.

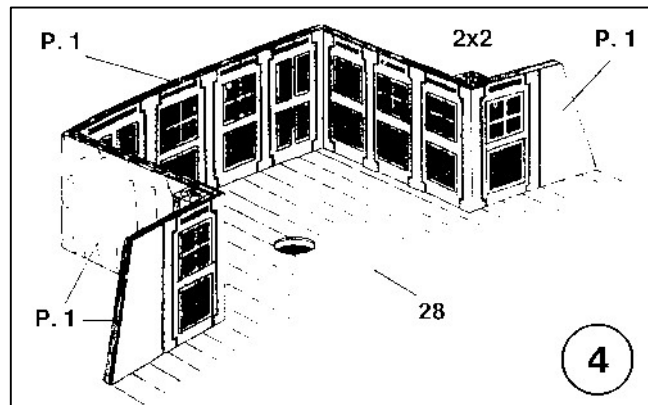

Make up the steering wheel supports from 2x6 Walnut strip and assemble the wheel house group as shown in **Fig.5** below, cutting the brass capstan to length so that the supports sit into the pre-cut slots in the deck. Glue the assembly into place. Drill a $\varnothing 1$ hole either side of the capstan and feed a length of rope around the capstan and into the deck as shown in **Fig.5**. **Photo.7** below shows the assembled cabin structure and wheelhouse group.

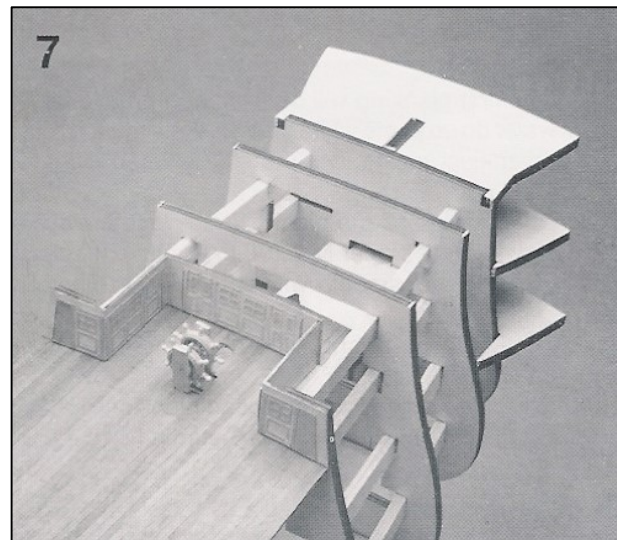
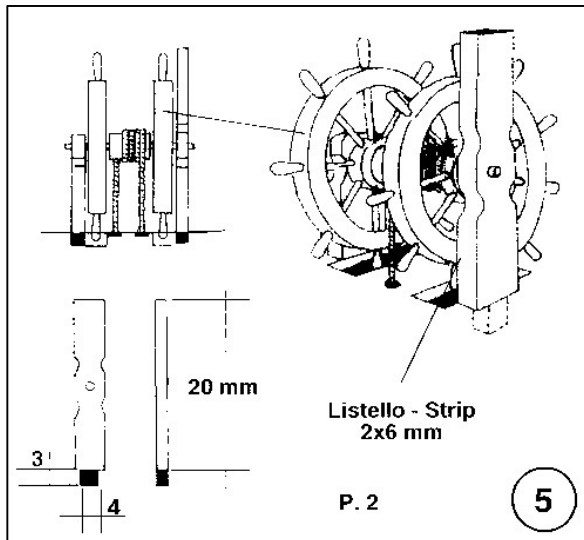

Fit the poopdeck n.29 in place, ensuring that the stern end is aligned with the rear edge of the sterncastle and that the sides are aligned with the frame edges. Clamp the deck so that it is in contact with the curved tops of the frames and allow to dry. Cover with 0.5x3 Walnut planks using the method described previously. Approximately 95 planks will be needed. Smooth the deck and coat with sanding sealer.

Fit the transom n.30 to the sterncastle securing with pins until set. Plank the inside face of the transom with 1x6 Walnut planks laid vertically. Sand and varnish over.

STEP 7: Planking the Hull – Inner layer

The first (inner) layer of planks is made from 1.5x6x900 Walnut planks; the second (outer) layer of planks is made from 1x6x900 Walnut planks. The thick black line on the side section on **Plan 3** shows the position of the first planking strip, which should be positioned to run parallel to the dummy cannon barrel support strips. Use a plank bender to form the plank around the bow. Pin the plank in position with shouldered pins (inserted in the frames beside the plank) or small nails through the centre of the plank – but not driven home as these will be removed later. Repeat this on the other side of the hull.

Place a second strip on each side below the first planks. See **Photo.8** below. Now work alternately down each side of the ship to avoid twisting the hull, until you have eight planks each side. From now on, the planks will require shaping.

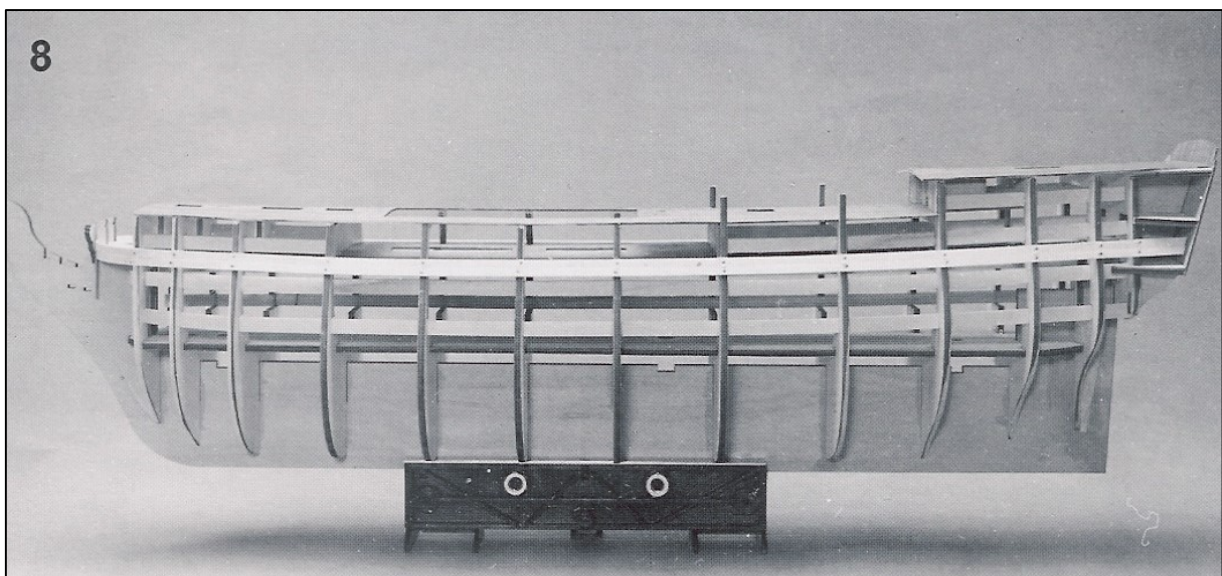

Proceed with the planking in the sequence recommended in the specific instructions on planking provided in the last section of this booklet. Where necessary, trim the planks with a Stanley-type blade or a hobby plane as shown in **Fig.6**.

Plank from the top to the bottom alternately on each side and then add more planks above the first plank to bring the sides up to the deck level and to make the parapet walls above the decks. Use the cardboard gunport pattern supplied as a template for the parapet wall heights.

When the first planking has been fitted, remove any nails or pins and fill any cracks or splits with slivers of wood. Dilute some PVA or aliphatic glue and using a flat brush, coat the entire surface of the hull planking squeezing the glue into the joints (see **Photo.9** below).

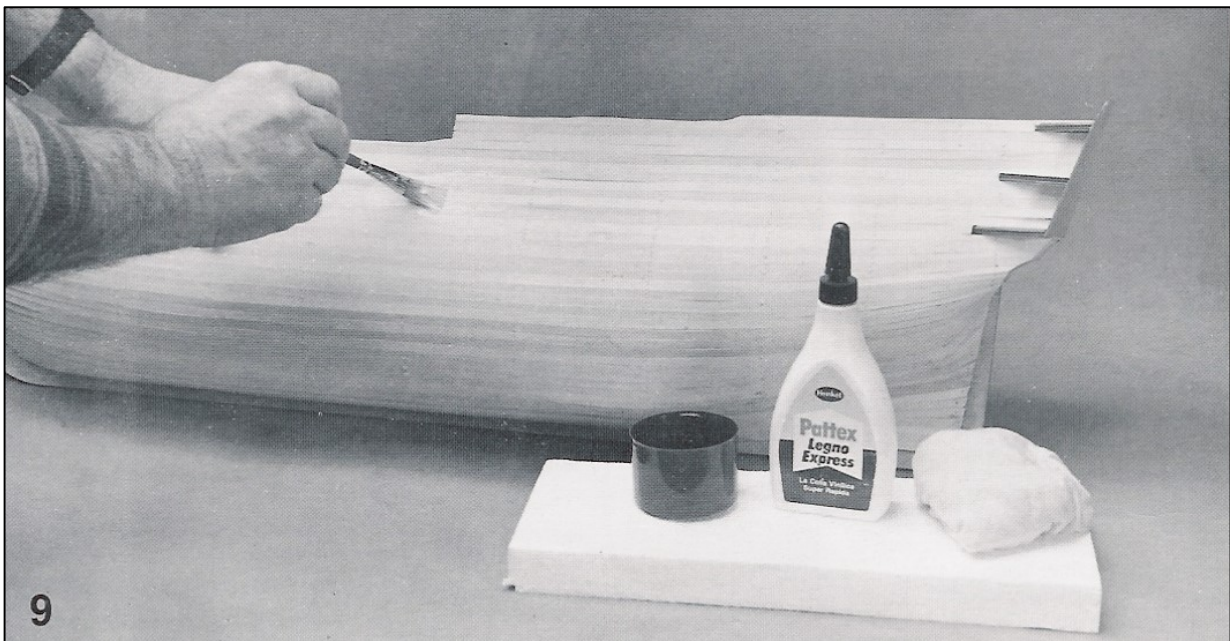
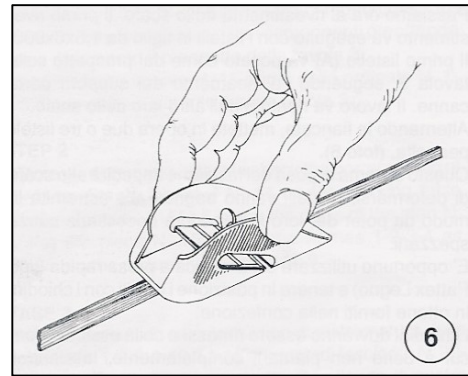

When the glue has dried, scrape the hull surface with a blade or scraper **Art8290** to remove any high spots and then sand it smooth (see **Photo.10** below). **Photo.11** and **Photo.12** show the plank tapering and the profile of the hull.



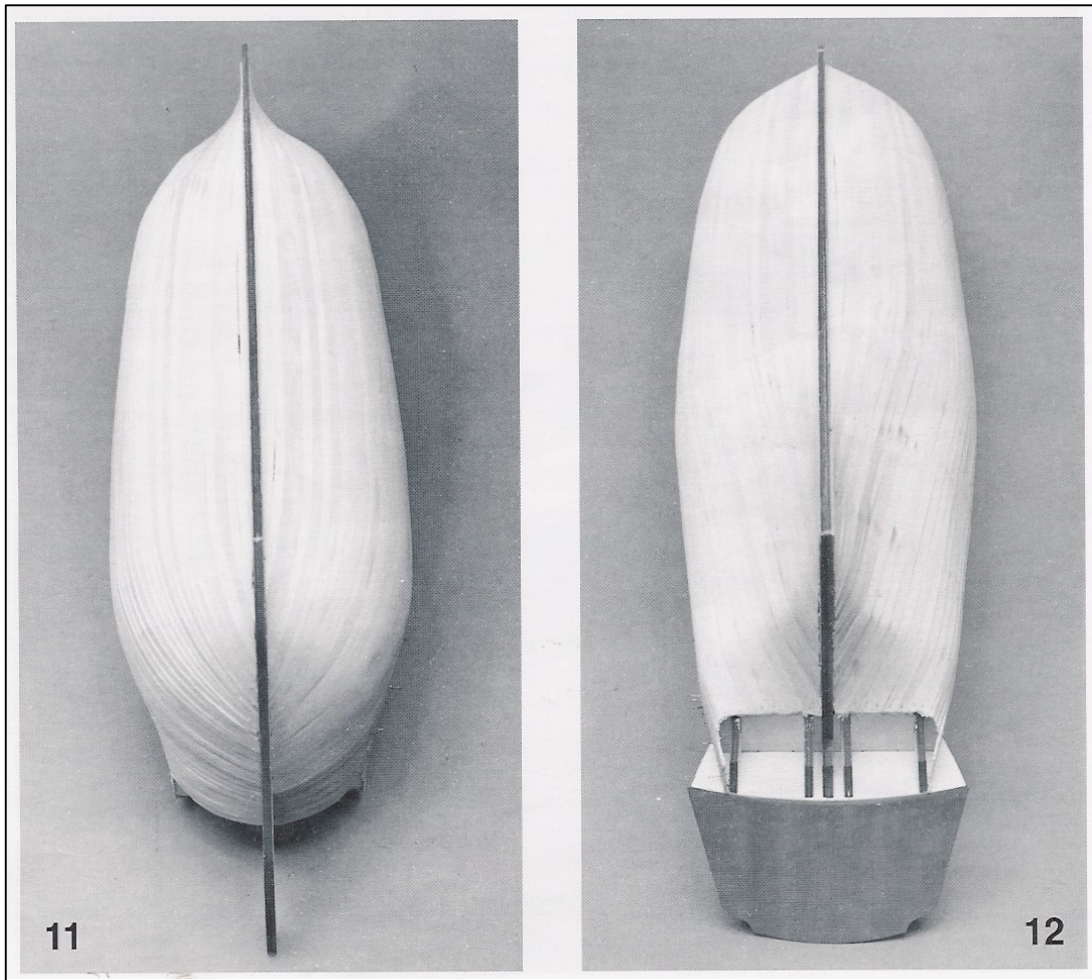

STEP 8: Planking the Hull – Outer layer

The second (outer) layer of planks is made from 1x6x900 Walnut planks using the same technique as the first layer. Start 2mm above the first planks so that the joints are staggered for added strength (see **Photo.13** and **Photo.14** overleaf). When completed, remove all pins, fill any splits or pinholes and scrape and sand the hull smooth.

STEP 9: Adding the Stern Gallery

Fig.7 shows how to fit parts n.32 and n.33 to the stern. Shape the parts to fit the line of the hull and clamp them in place with pins until set. Plank the stern brackets with 1x6 and 1.5x3 Walnut planks following **Fig.8**. Shape the strips with a file and sandpaper for an exact fit. Cut a Ø10 opening for the rudder stem.

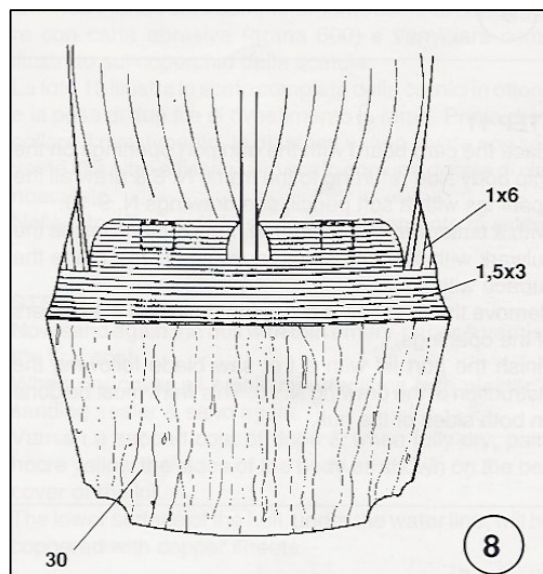
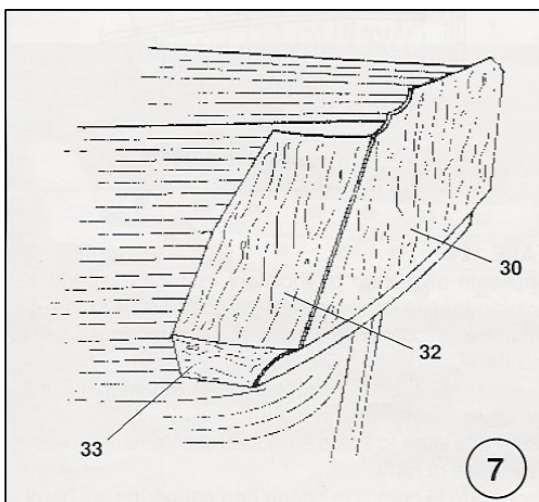

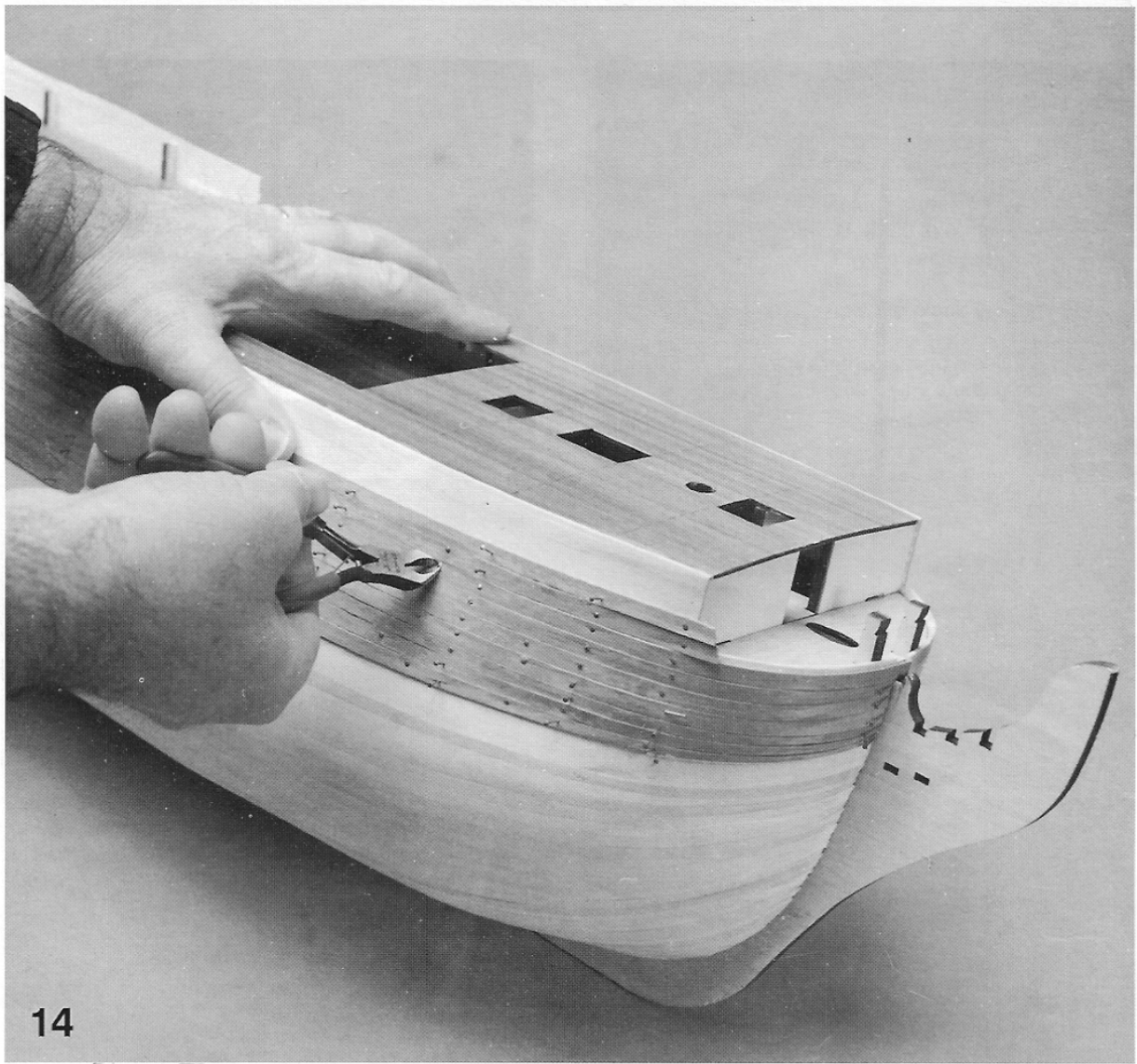
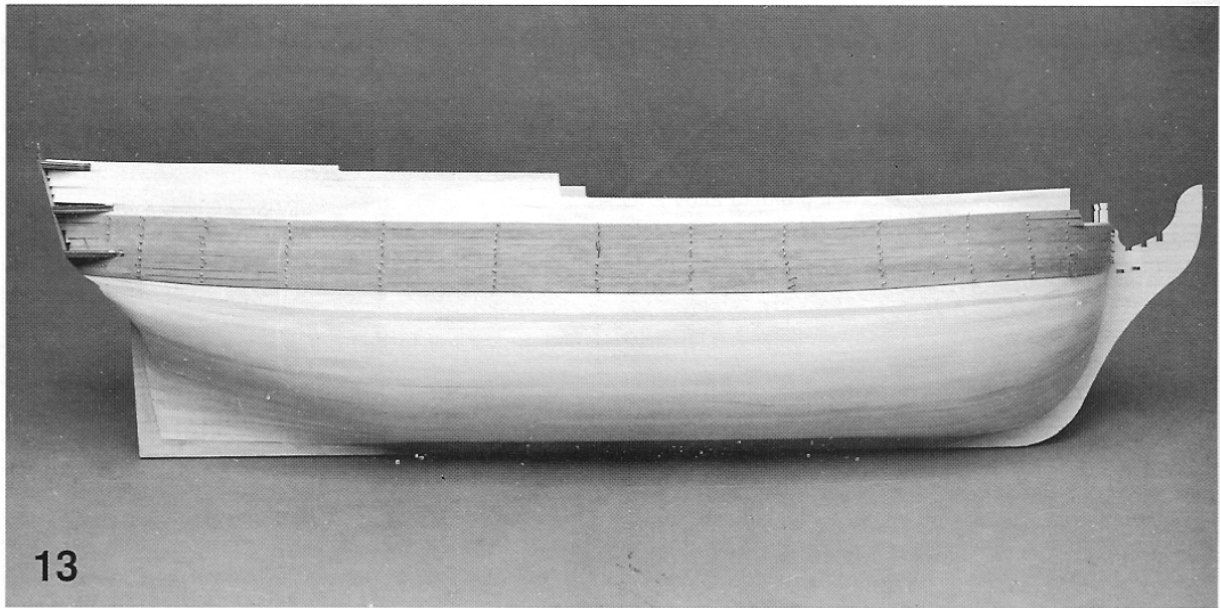

STEP 10: Cutting the Gunports

Using a sharp craft knife and a straightedge cut the openings for the gunport lids out of the cardboard template supplied. Place the template on the port (left hand) side of the hull and align it with the decks, positioning the notch in line with frame n.8 and the front top corner with the forecastle deck, securing it in place with pieces of masking tape. Mark the openings on the hull planks using a soft pencil. Remove the template, turn it around and repeat the process on the starboard (right-hand) side. See **Fig.9**.

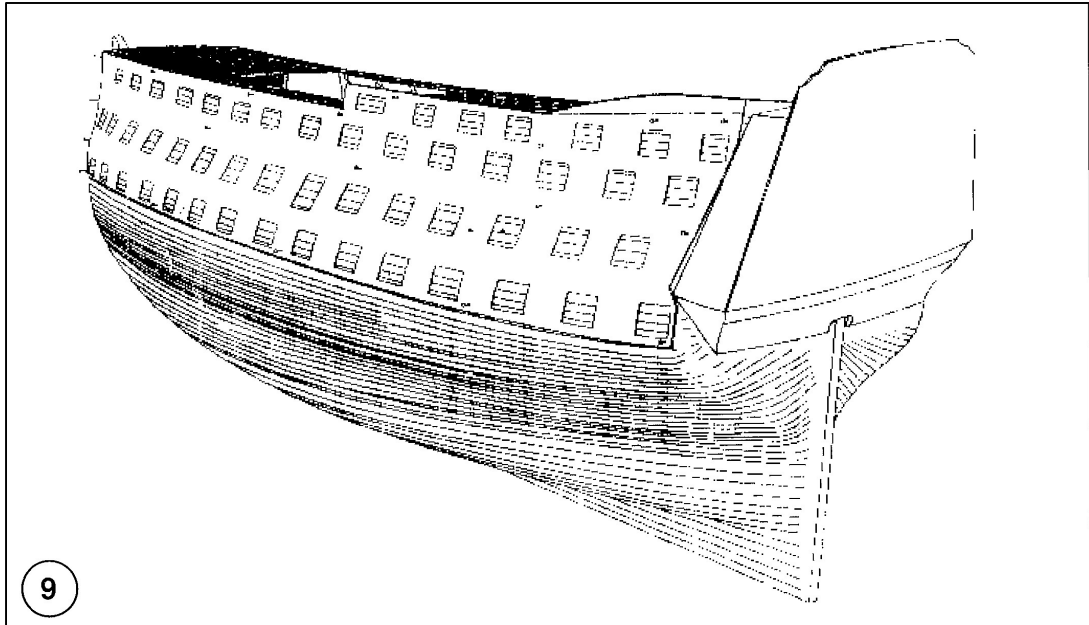

Remove the cardboard template and drill a small hole in each corner of each gunport. Use a small saw blade to cut out each gunport and file the ports to size. See **Fig.10** below. Be careful not to damage the dummy cannon barrel support strips behind the gunports.

Cut two gunports under the stern as shown in **Fig.8** previously.

With a craft knife or razor saw, remove the frame teeth as shown in **Fig.11**. Plank inside the bulwarks with 1x6 Walnut plank laid horizontally. Sand and varnish over.

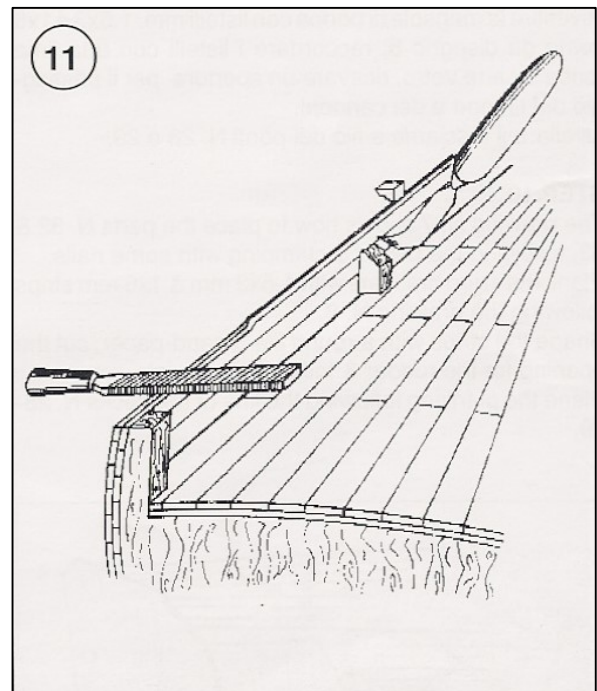
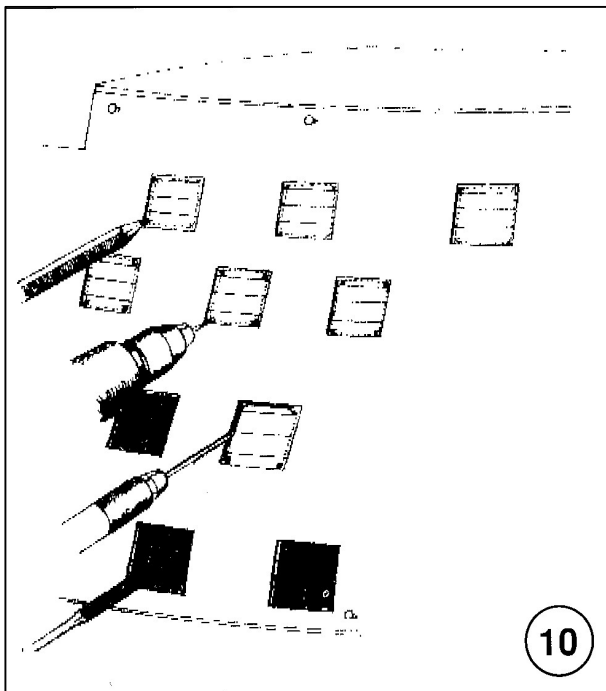

STEP 11: Gunwales and Gunports

Gunwale planks. Using the side view on **Plan 4** and **Fig.12** as guides, fit a single lower gunwale plank made from **1.5x6x900** Walnut plank to each side of the hull. Fit a single upper gunwale plank also made from 1.5x6x900 Walnut plank to each side. Fit two middle sets of gunwale planks (three per set) made from **1.5x4x900** Walnut planks to each side. Before gluing the gunwale planks to the sides of the hull, mark their positions using tape. Check that they are at the same height either side. These planks run the entire length of the hull, from bow to stern. To form them around the bow, they will need to be bent using a plank bender, glued and held in place with pins until the glue has dried.

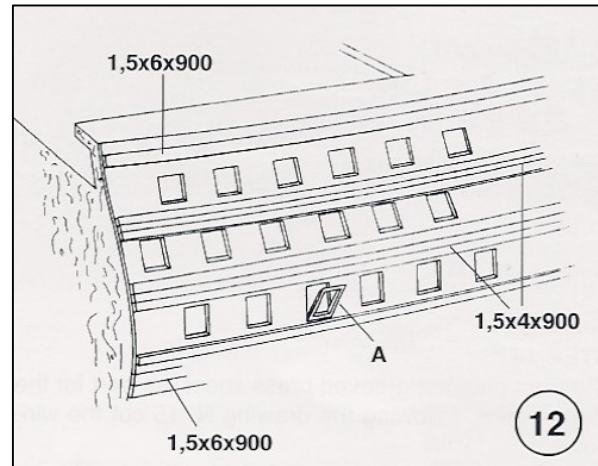

Gunports. Fit the brass gunport frames to the hull without gluing. Remove the gunport frames and paint the inside edges of the frames red (see **Fig.14**). Fit two of the frames with the clear plastic windows provided to make the officer's cabin windows (top row, second from stern). Paint red window sashes on the rear of the windows.

Step 12: Painting and Coppering

Sand the hull again with thin emery-paper and apply a coat of sanding sealer. When dry, fill any imperfections with filler and sand again. Apply a second coat of sanding sealer.

Taking the measurements from **Plan 4**, and using a jig as shown in **Fig.13**, mark the waterline all around the hull. The hull below the waterline will be 'coppered' after painting with the copper plates supplied. When fully dry, mask off the stern galleries, the decks and the hull below the waterline to protect these areas from paint.

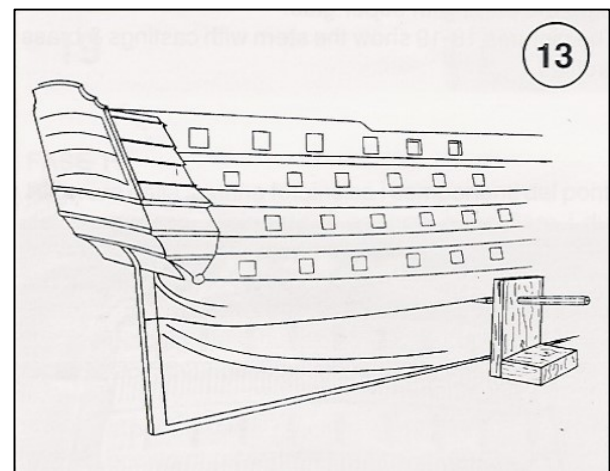

Paint the hull sides with matt yellow ochre and matt black acrylic enamel as shown on the colour photographs on the box. Set aside to allow the paint to dry thoroughly. We suggest that the yellow ochre paint is applied first, then is masked, then the black paint is applied. We recommend the use of an airbrush and 3 coats of matt paint diluted to 3:1 with appropriate thinners. Alternatively, paint by hand using matt paint, a good quality sable brush and employing light longitudinal brush strokes.

Fit the gunport frames in place in the hull and stern secured with instant glue, ensuring that the two glazed windows are fitted to the top row, second gunports from the stern.

'Copper' the hull and keel areas below the waterline using the plates supplied in the kit. **Fig.16** and **Fig.17** show the details of the Coppering. Clean the backs of the plates with thinners and stick the plates to the hull with instant glue.

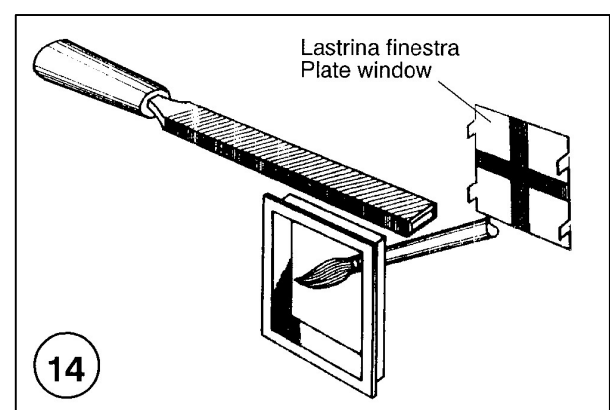

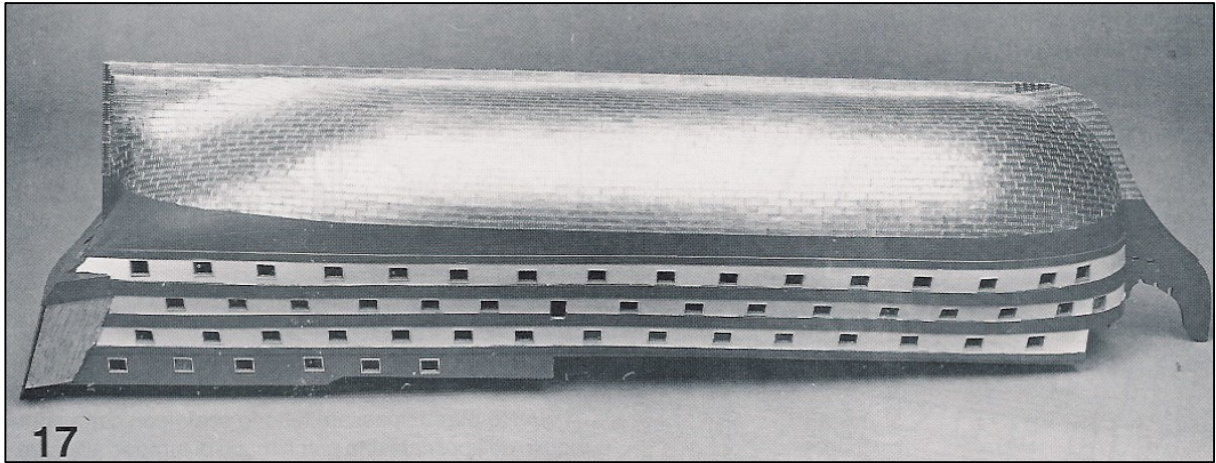

STEP 13: Making the Display Cradle

Photo.15 shows how to assemble the display cradle from part n.31, Walnut planks 6x6x700 and 8x8x500 plus the four base mouldings supplied. Sand and varnish the base with two coats of matt varnish or sanding sealer, sanding lightly between coats. Shape and position the wedges on top of the side chocks so that the *Victory* does not rock on the cradle. **Note that this cradle is for display purposes only and should not be used for structural work as it is relatively fragile.**

