

ACADEMY

HOBBY MODEL KITS

A991/#1399

# M3 STUART "HONEY"

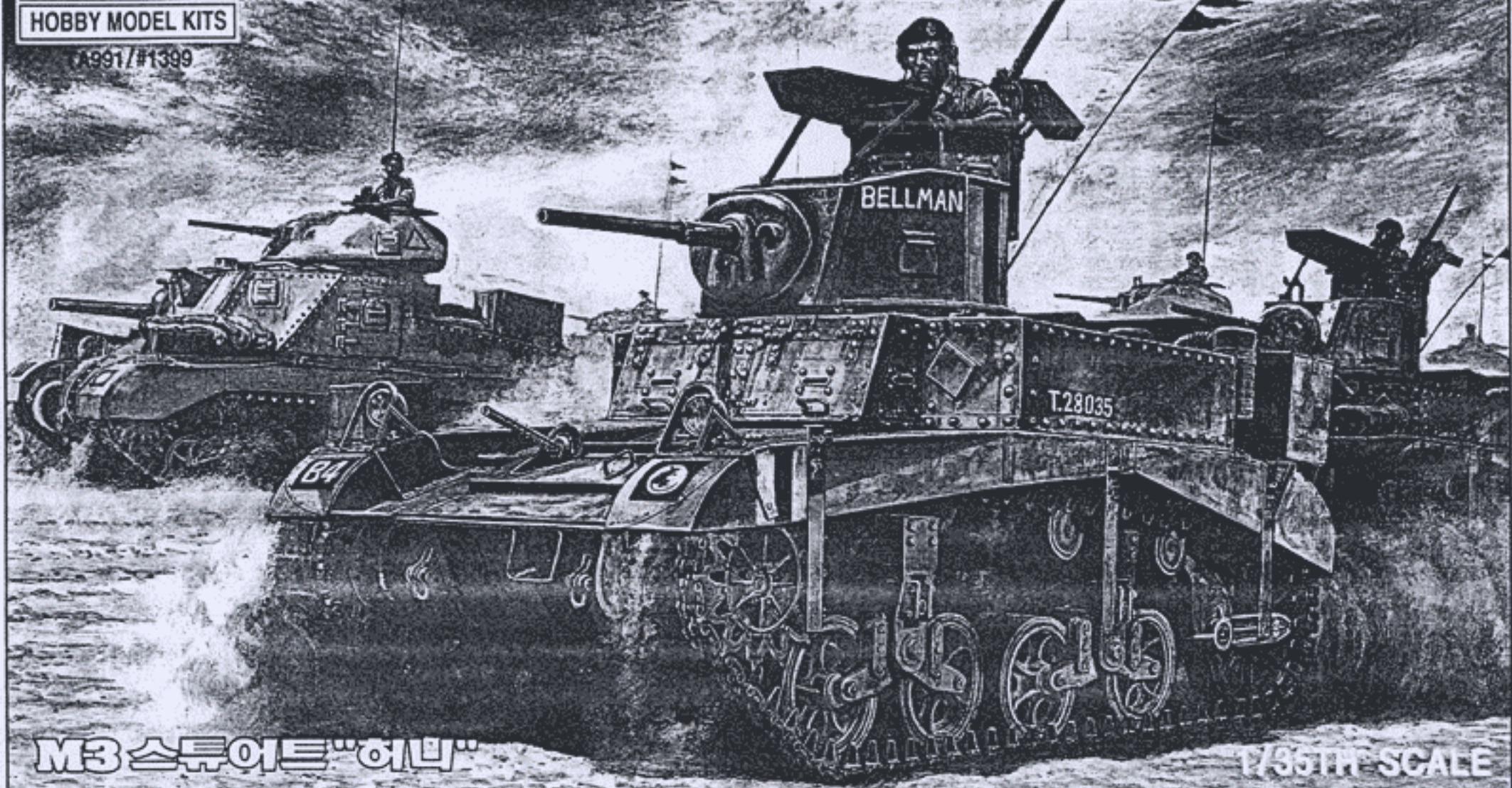

M3 스튜어트 "허니"

1/35TH SCALE

The British named the M3 "General Stuart" upon receipt of the tank under the Lend-Lease program in June of 1941. The tank's ability to "shoot and scoot" as well as keeping the crew safe from small arms fire, earned an affectionate nickname of "Honey" by its operators. The British cavalry men liked this tank since it can travel 10 to 20 mph faster than their own or enemy tanks, and for its ease of maintenance. The M3s were designed to replace the outdated M2c. The M3 incorporated a thicker armor, lengthened hull, and a trailer idler wheel to act as another road wheel to decrease ground pressure and improve weight distribution. The M3 turret had three pistol ports and shortened recoil mechanism. It was also equipped with a 37mm M6 gun, which was adequate early in the war, but by 1942, the German counterparts far surpassed the range of the M3. The narrow width of the M3 could not accommodate a larger gun. The M3A1 was fitted with a Westinghouse gyrostabilizer, a turret basket and an Oil Gear hydraulic traverse mechanism, but lacked a turret cupola. The earlier version of the M3A1, the Stuart III, was powered by Continental W-970-9A 7-cylinder radial gas 250 hp engine but by mid 1941, the Stuart IVs came off the production lines with Guiberson T-1020 air cooled radial diesel engine.

Im Jahre 1940 erkannte die U.S. Army die Notwendigkeit, den M2 zu ersetzen. Das neu entwickelte Modell hatte einen dickere Panzerung auf verlängertem Rumpf und ein aufliegendes Leitrad, um den Bodendruck zu verringern. Der Turm des M3A1 besaß drei seitliche Luken, ein hydraulisches Schwenkwerk mit Turmkorb, aber keine zusätzliche Kuppel. Der M3A1 war mit einer stabilisierten 37mm M6 Kanone bestückt, das Westinghouse System ermöglichte Fahren und Feuern gleichzeitig. Die 4410 Stück mit dem Continental W-970-9A Sternmotor (Benzin) wurden von den Briten als Stuart III bezeichnet. 211 Einheiten des M3A1 mit dem Guiberson T-1020-4 luftgekühlten Sternmotor (Diesel) nannte man Stuart IV. Beide Typen wogen 15 Tonnen und hatten vier Mann Besatzung. Der einzige Nachteil war das kleine Kaliber der 37mm Kanone, welches ab 1942 auf dem Gefechtsfeld unterlegen war. Das beengte Chassis des M3 erlaubte keinen Einbau eines größeren Kalibers. Zwischen Mai 1942 und Februar 1943 wurde der M3A1 von der American Car Foundry hergestellt. Die britischen Truppen erhielten den M3 im Rahmen des Leih- und Pachtvertrages im Juni 1941. Sie nannten das Fahrzeug "Stuart", nach dem berühmten konföderierten Kavalleriegeneral aus dem amerikanischen Sezessionskrieg. Wegen seiner Fähigkeit zum gleichzeitigen Fahren und Feuern sowie dem Schutz vor kleinkalibrigem Beschuss war der "Stuart" bei den Truppen sehr geschätzt und bekam den Kosenamen "Honey" (Liebling). Auch war er 10 bis 20 mph schneller als die vergleichbaren Typen aus englischer Produktion und sehr wartungsfreundlich.

英軍は、1941年の武器貸与計画の下に同戦車を受領した時、M3型戦車を「スチュアート」と名付けた。同戦車の「発射し、突進する」ことができる能力および小火器火力から乗員を安全に保てる能力とは、その乗員による愛情を込めた「ハニー」のニックネームをかちとった。英国陸軍の戦車兵は、同戦車がこれまでの英戦車もしくは敵軍の戦車より毎時10から20マイル早く走ることができ、また同戦車の整備が容易であることから、同戦車を好んだ。M3型戦車は、古いM2型戦車の代替目的で設計された。M3型戦車は、より厚い装甲、車体の延長、対地圧力を減らしかつ重量分布を改善することができるもう一つのロード・ホイールとして機能するトレーラー・アイドラー・ホイールなどを装備していた。M3型戦車のターレットは、3つのピストル用発射孔を持ち、砲身の後退メカニズムは短くなった。また、同戦車は口径37ミリのM6型キャノン1基を装備し、これは戦争初期には十分であったが、1942年までに敵ドイツ軍は、M3型戦車の射程をはるかに凌駕した。M3型戦車の狭いタレットでは、より口径が大きい砲を搭載できなかった。M3A1型戦車は、ウェスチングハウス社製のジャイロスタビライザー、ターレット・バスケット、油圧旋回メカニズムを装備していたが、ターレット・キューポラを欠いていた。M3A1型の初期型のスチュアートIII戦車は、250馬力のコンチネンタル社製のW-970-9A7型星型エンジンが動力源であったが、1941年半ばには、スチュアートIV戦車が、T-1020型空冷ディーゼル星型エンジンを装備し、製造ラインを離れ登場してきた。

M3 스튜어트 경전차는 2차대전 초기에 사용되던 다른 경전차에 비해 긴 항속거리와 빠른 기동성, 편리한 조종성 등으로 인해 당시로서는 최고의 경전차 중 하나로 평가받았다. 1940년대에 들어서면서 미국 육군은 그동안 사용하던 구식전차인 M2를 대체하기 위한 후계차량으로 M3의 개발을 진행하였다. M3은 M2에 비해 강화된 장갑판과 더불어, 전차의 중량을 분산하여 지반압력을 줄여줄 수 있는 독특한 모양의 아이들러 휠, 그리고 무장이 강화된 포탑 등의 특징을 지니고 있었다. 4명의 승무원이 탑승하는 M3은 250마력의 콘티넨탈 W-970-9A엔진을 동력원으로 탑재하고 있었으며, 주무장으로는 회전포탑식의 37mm포를 장비하였다. 아울러 차체와 포탑엔 각각 1정씩의 Cal.30기관총을 부무장으로 장착하였고, 대공 사격용으로 1정의 Cal.30을 큐폴라에 추가로 장비하였다. M3 "허니"는 영국군 사용차량에 붙여진 애칭으로, 1941년 6월, 전시무기대여법에 의해 영국군에 인도되었으며, 북아프리카전선과 남태평양전선 등지에서 사용되었다. 하지만 시간이 지남에 따라 점차 강력해지는 독일군 전차의 화력과 무장 앞에서, M3이 지닌 37mm주포의 짧은 사정거리와 낮은 파괴력, 그리고 차체의 빈약한 장갑은 많은 문제점을 드러내게 되었다. M3은 비록 경전차라는 한계로 인해 여러 가지 문제점이 있었지만 상대적으로 강력한 전차가 등장하지 않았던 2차대전초기의 북아프리카와 남태평양 전선등지에서 많은 활약을 펼쳤다.

 <p>붙인다. Cement parts Coller Kleben Pegar Incollare Colar Kleven</p>	 <p>붙이지 않는다. Do not cement Ne pas coller Nicht kleben No pegar Non incollare Nao colar Niet kleven</p>	 <p>수행 중입니다. Repeat operation Répéter l'opération Vorgang wiederholen Repitir la operación Ripetere Repitir a operação Herhalen</p>	 <p>판사지를 붙인다. Decals Décalcomanies Abziehbild</p>	 <p>무게추를 넣는다. Add weight Lester Gewicht</p>	 <p>구멍이나 홈을 채워준다. Use filler Mastiquer Schließen</p>
 <p>잘라낸다. Cut away Couper Schneiden Cortar Tagliere Cortar Snijden</p>	 <p>선택한다. Optional parts Choix Auswahlmöglichkeit Eleccion Scelta Opcao Keuze</p>	 <p>반대측도 포함한다. Repeat for opposite side Répétition de la page Wiederholung für gegenüberliegende Seite</p>	 <p>구멍을 뚫어준다. Make hole Faire un trou Öffnen</p>	 <p>주의한다. Be careful Faire attention Hier Vorsicht</p>	 <p>색칠 및 판사지 붙이기 번호 Painting scheme number Numeros de la lista de pinturas Lackierzeichnungsnummern</p>









**주의!**  
**WARNING!**



**▲ 보호자 분께서는 반드시 읽어 주십시오.**

- 조립하기 전에 취급 설명서를 꼼꼼히 읽어 내용을 충분히 이해한 상태에서 조립하여 주십시오.
- 부품을 자를 때는 해당번호를 확인한 뒤 니퍼 등으로 깨끗이 잘라 주십시오. 칼을 이용하여 부품을 다듬고 자를 경우 손을 다치지 않도록 세심한 주의를 기울여 주십시오.
- 작은 부품 따위를 절대로 입에 넣지 마십시오. 잘못하여 삼킬 경우 질식 등의 위험이 있습니다.
- 자칫 턱을 부러가 있으므로 3세 미만의 어린이에게는 절대로 주지 마십시오.
- 잘라낸 부품은 깨끗이 다듬어 조립하고 남은 쓰레기는 분리하여 잘 버려 주십시오.
- 기능상 부득이하게 튀어나온 부분이 있을 수 있습니다. 취급 시 충분한 주의를 기울여 주십시오.
- 제품 및 부품이 포장된 비닐봉지는 개봉 후 즉시 어린이의 손에 닿지 않는 곳에 잘 버려 주십시오. 머리에 튀겨서쓰거나 얼굴을 덮을 경우 질식의 위험이 있습니다.
- 색칠 및 접착을 위하여 모형용 도료 및 접착제 등을 사용할 때에는 창문을 열어 환기를 시키고 화기를 멀리하여 주십시오. 사용하고 남은 도료 및 접착제는 어린이의 손이 닿지 않는 곳에 잘 보관하여 주십시오.

- Before starting to assemble, read the instruction manual very carefully to understand well everything of the instructions.
- Before cutting a part off sprue, check the part number again and use proper tool such as nipper to cut it clearly. Take care not to be hurt in use of modeling knife to cut or trim parts.
- Never put small parts in the mouth to avoid any danger of suffocation by accidentally swallowed ones.
- Never let children less than 3 years old have it to avoid any danger of taking it.
- The product may have some protruding parts for functional reasons and take care of handling it always.
- After cutting a part off sprue, trim it clearly to assemble and the wastes should be properly sorted to dispose.
- Plastic bags packed with the product and parts should be disposed in a proper place immediately to keep out of children to avoid any danger of suffocation by pulling it over head or putting it over face.
- Before using modeling colors or cement, open windows to keep the room well ventilated and do not use near fire or flame. After using them, keep in a proper place out of children.

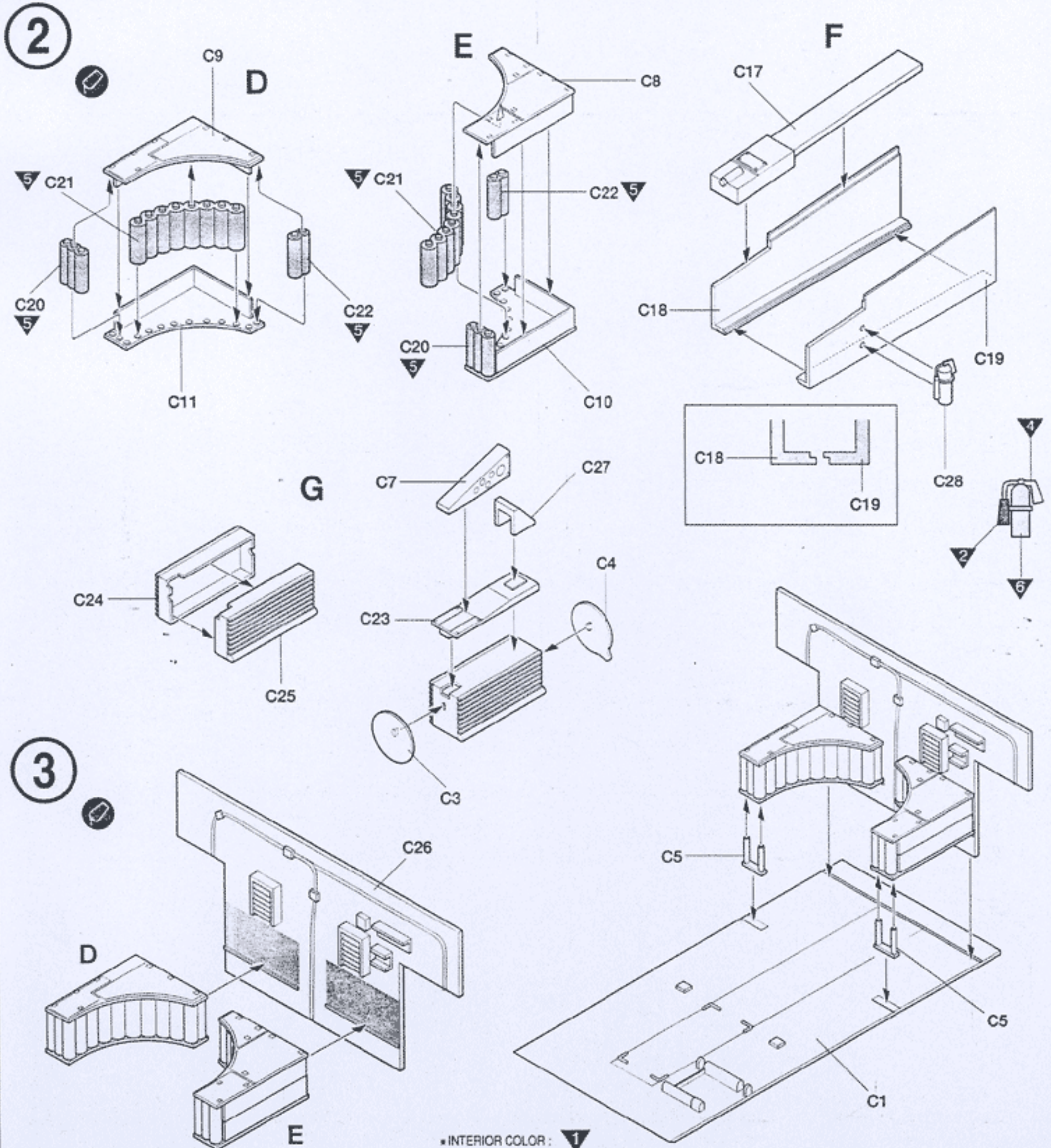

◆ INTERIOR COLOR :  
치채내부색



4

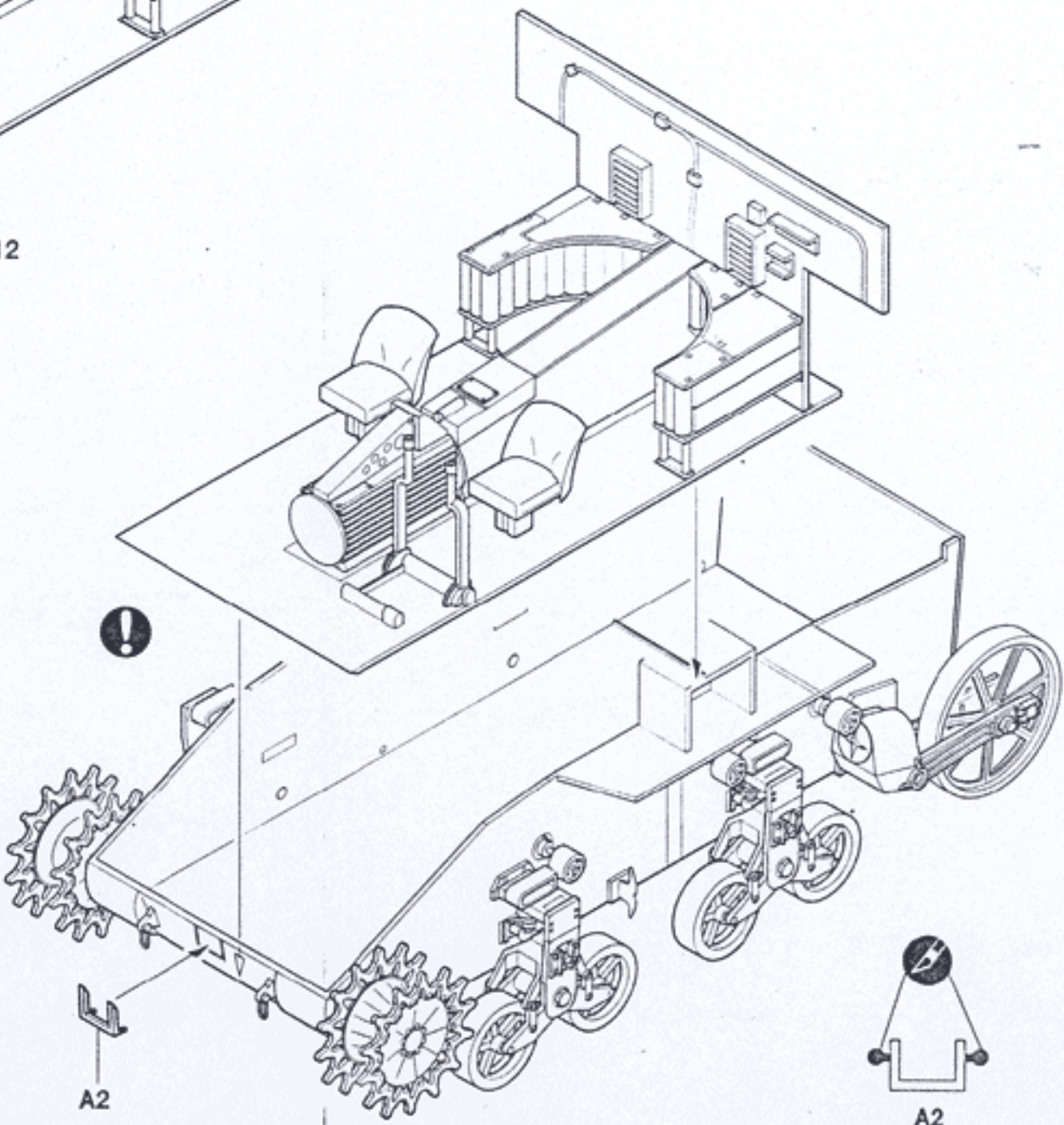
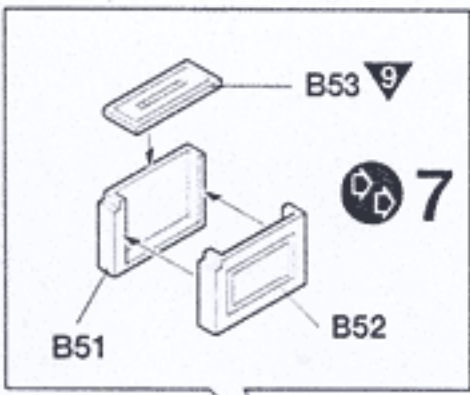
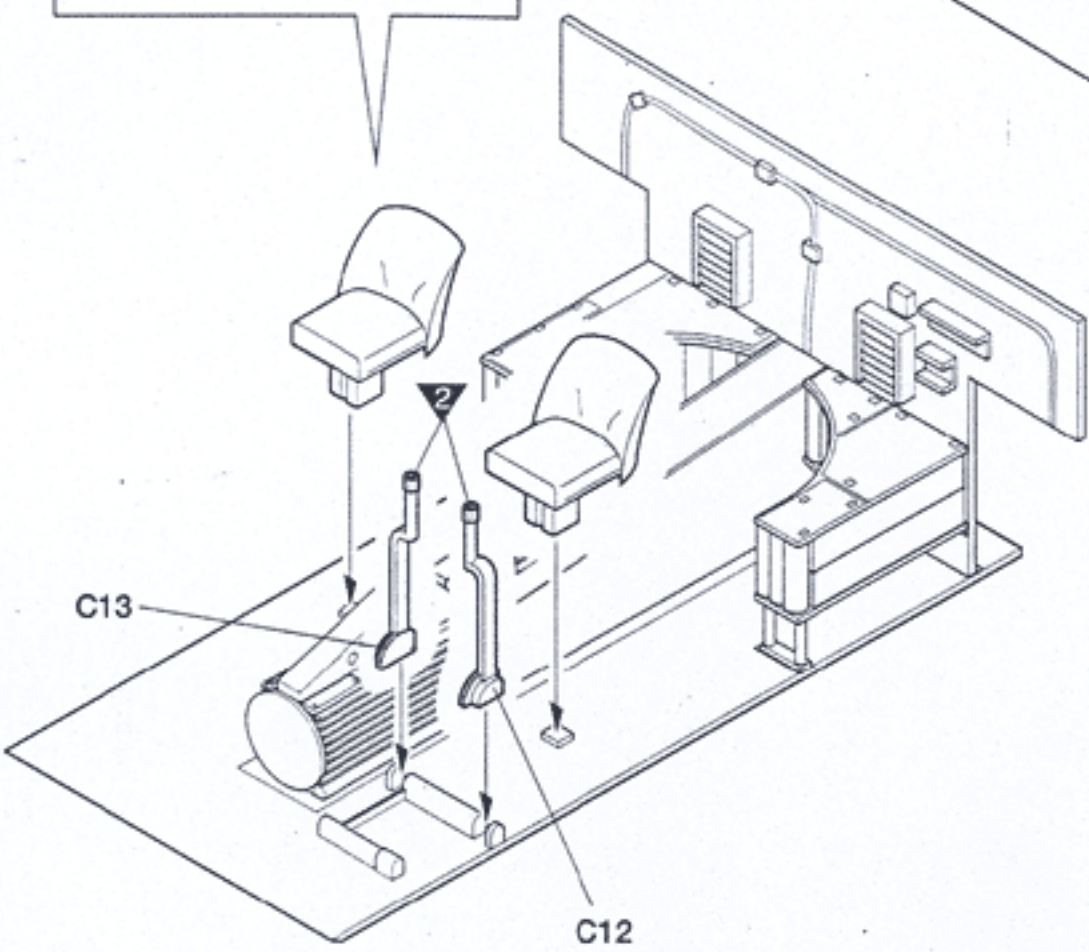
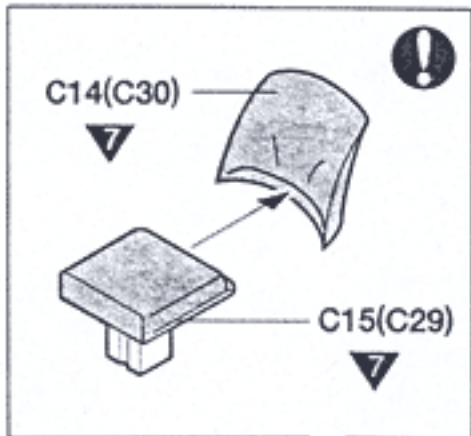
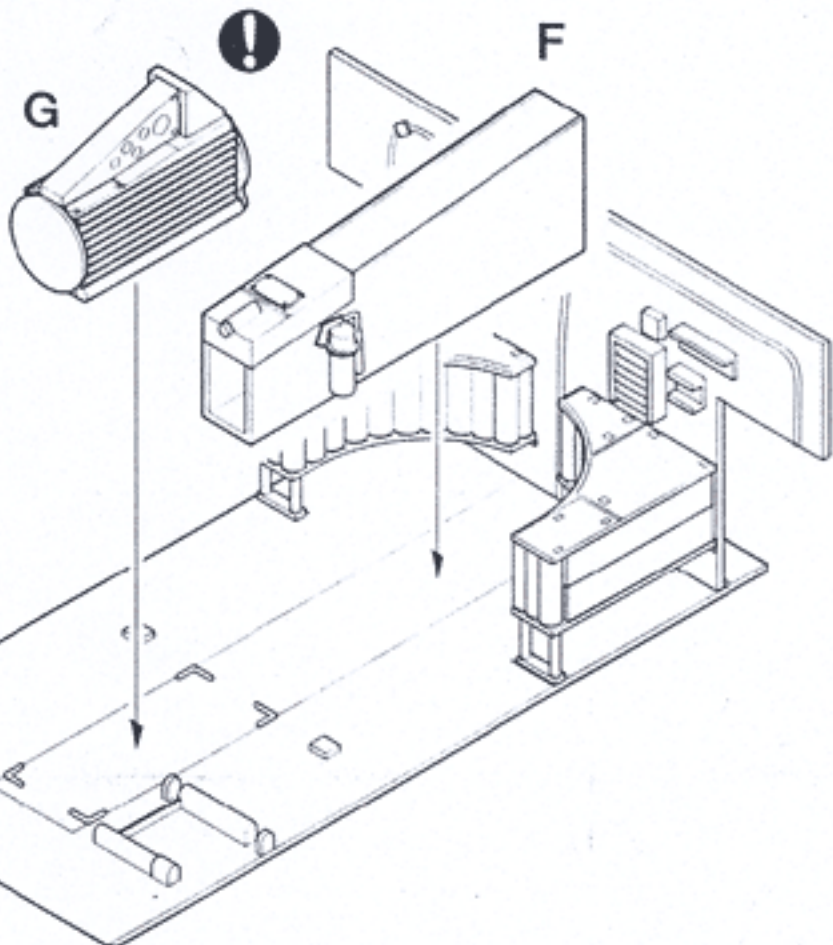



5

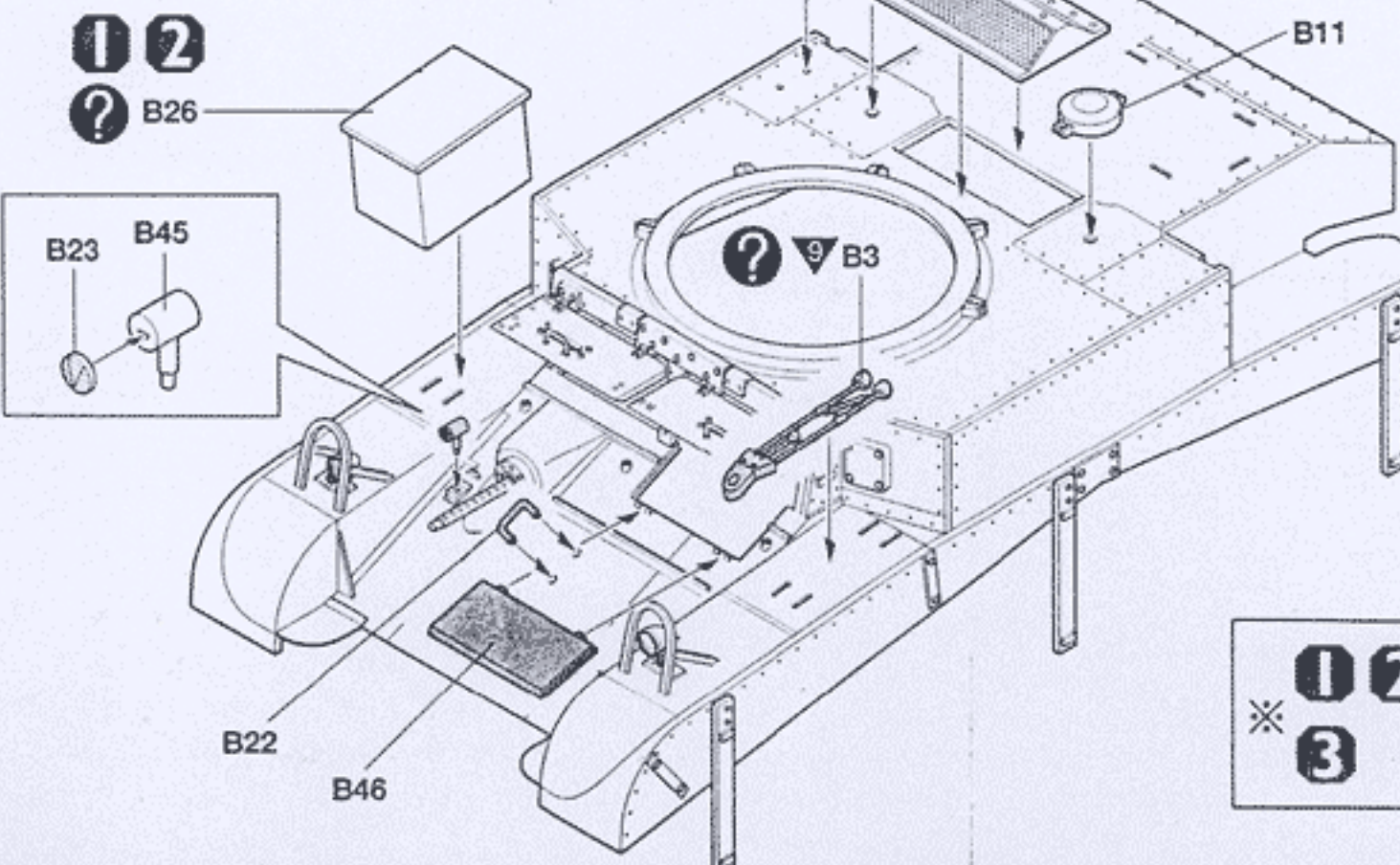
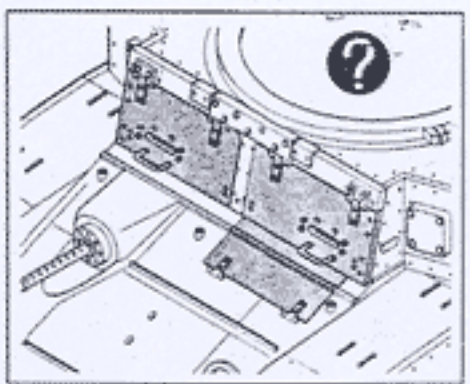
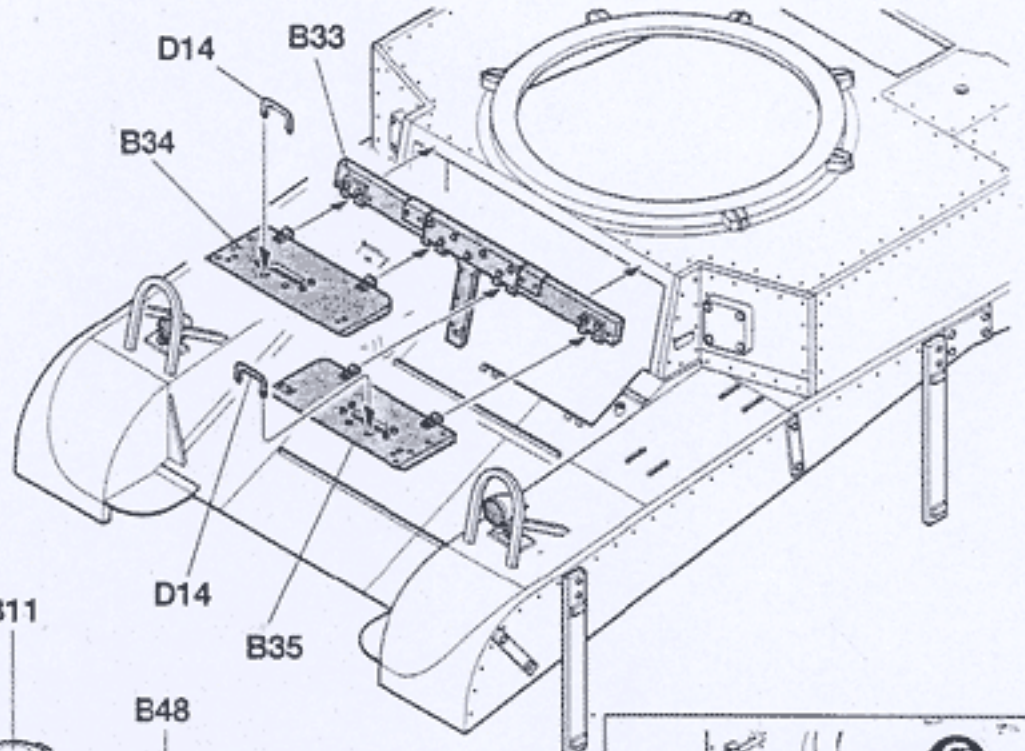
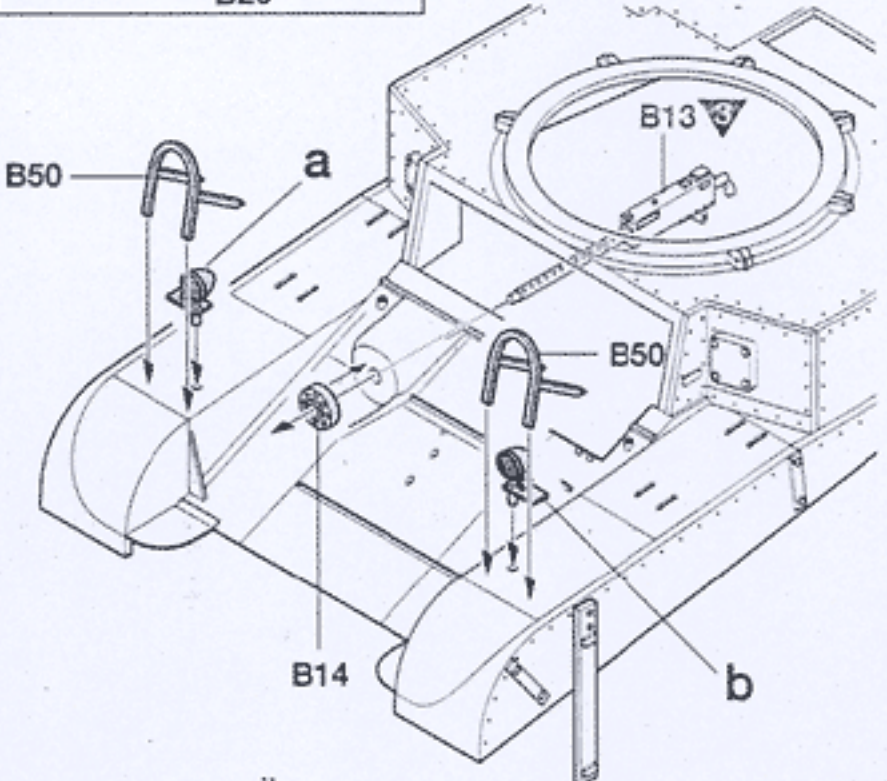
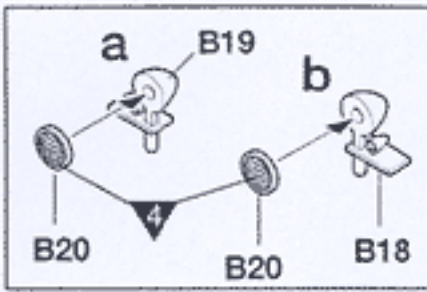
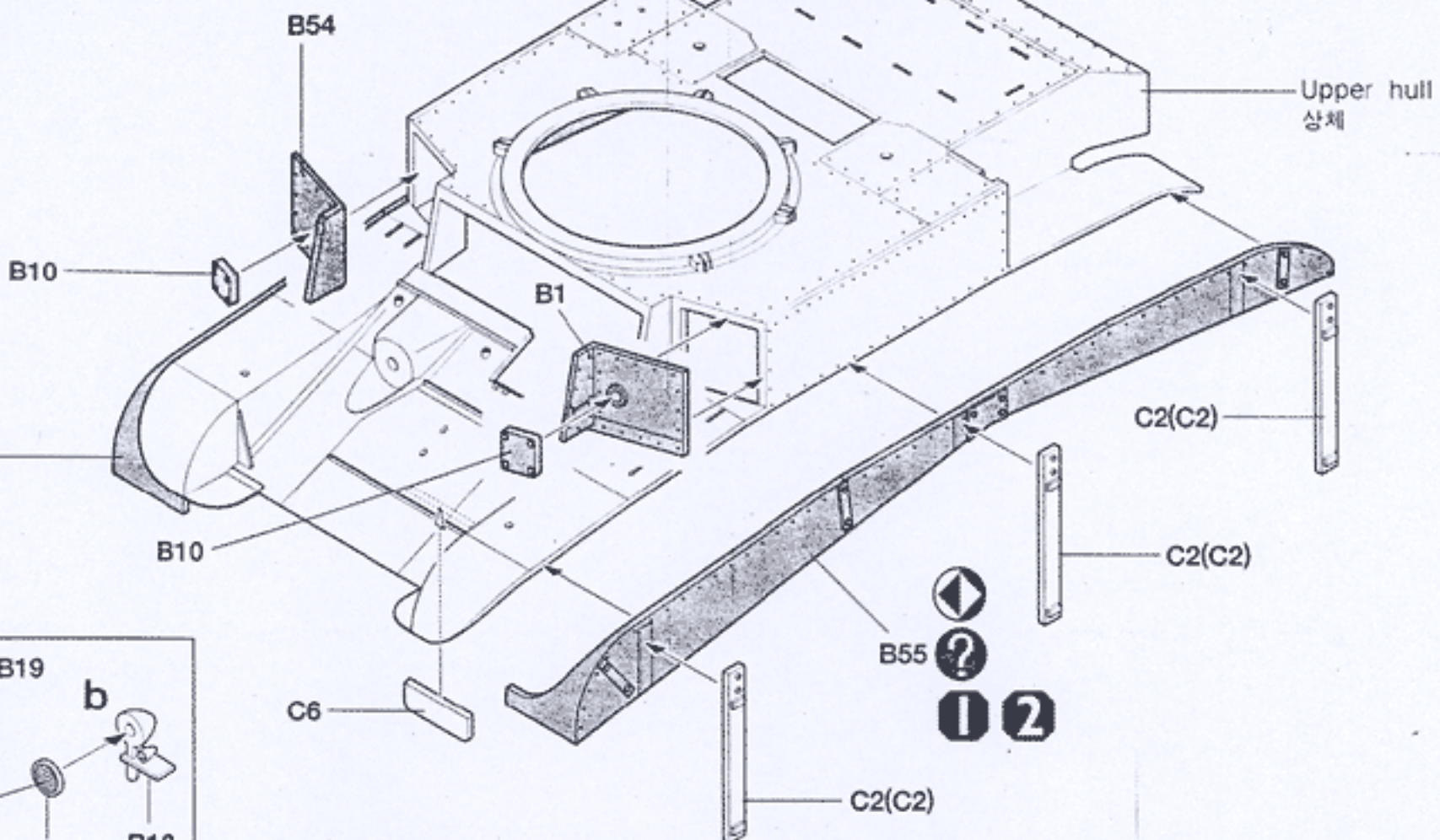

1 2 — British version  
 영국군형  
 ※ 3 — US version  
 미군형



6

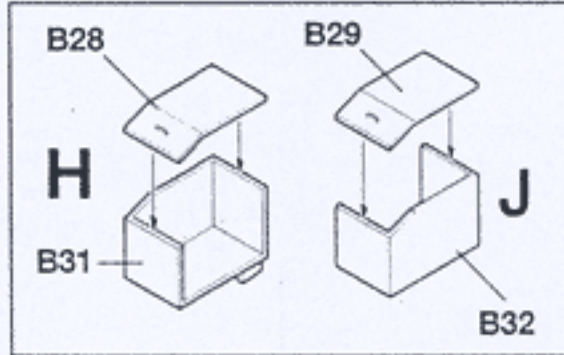
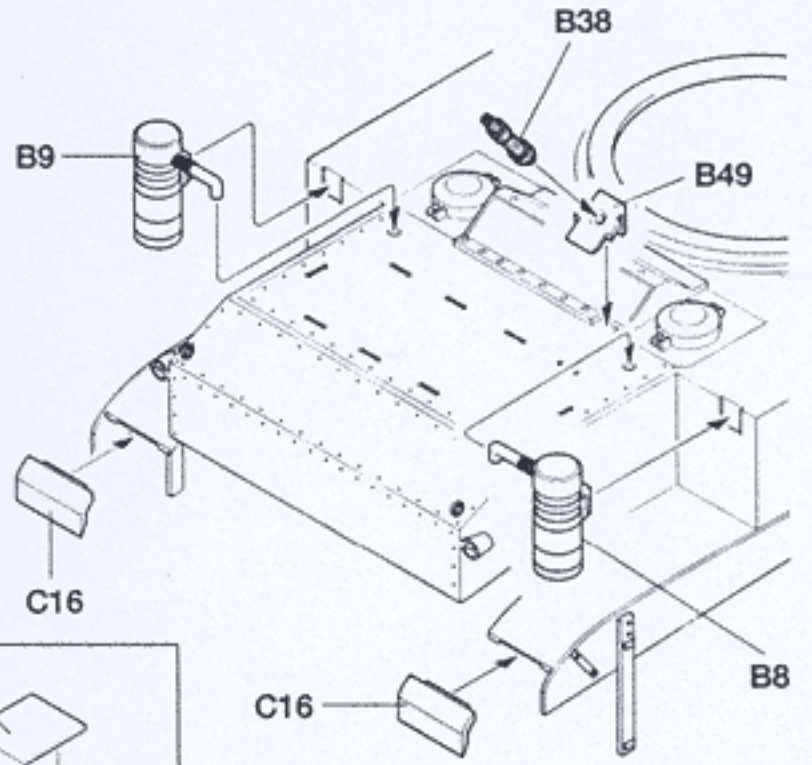
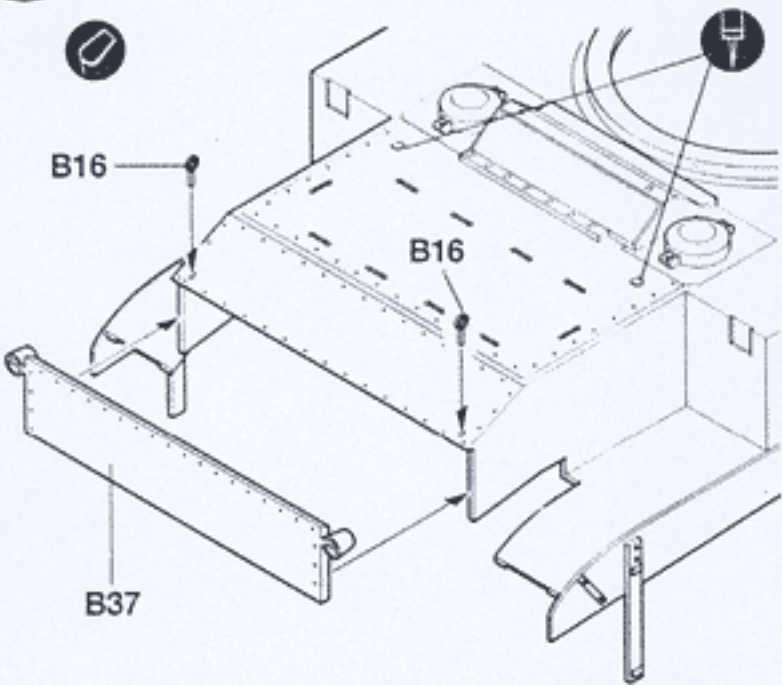

**1 2** — British version  
 영국군형  
 \* **3** — US version  
 미군형

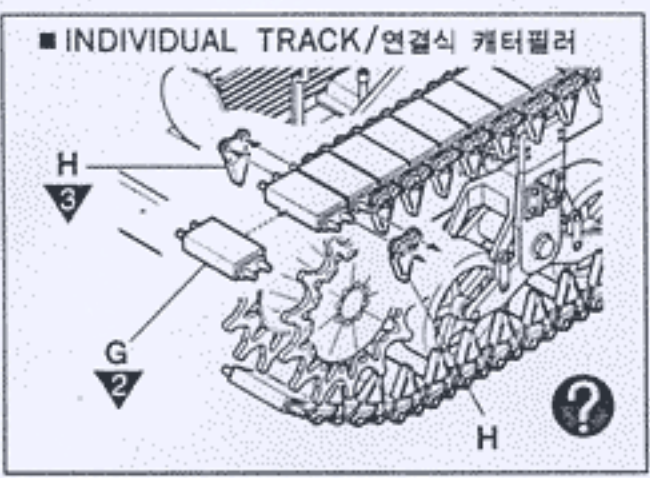
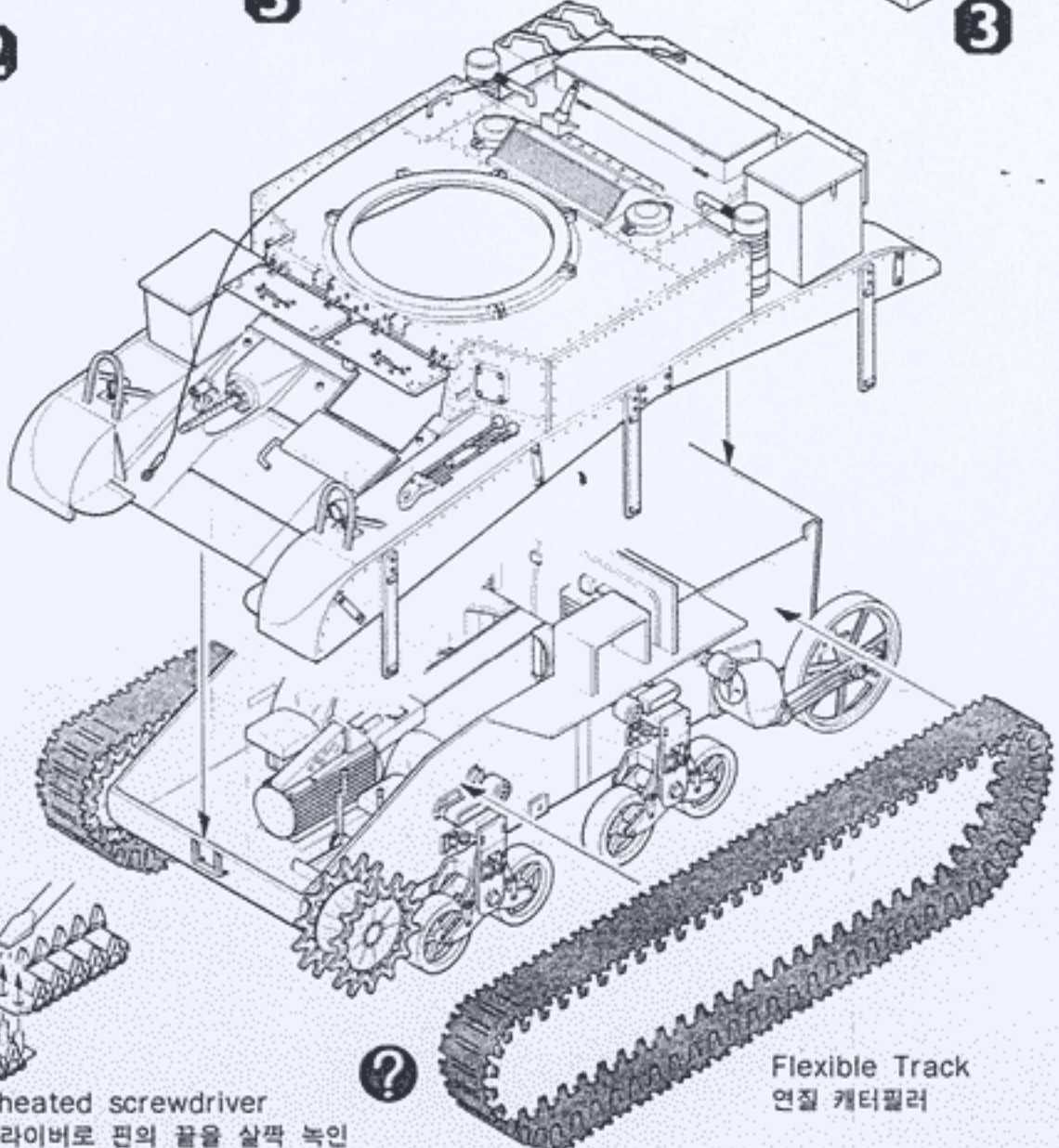
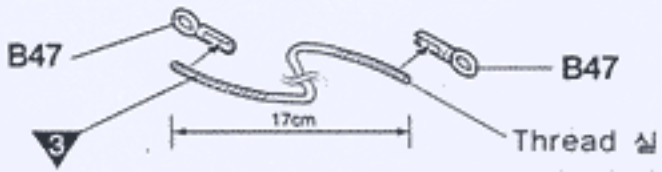
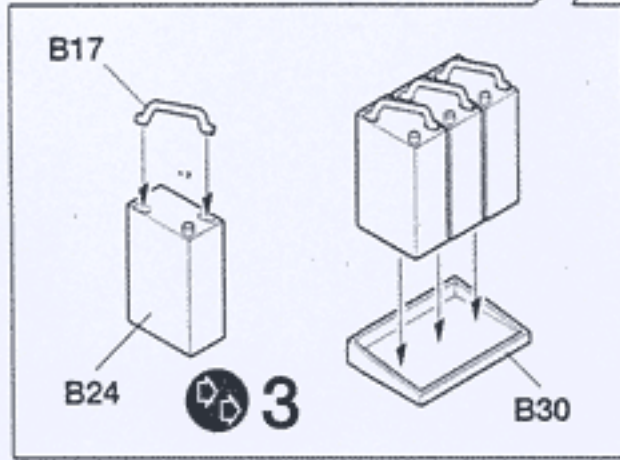
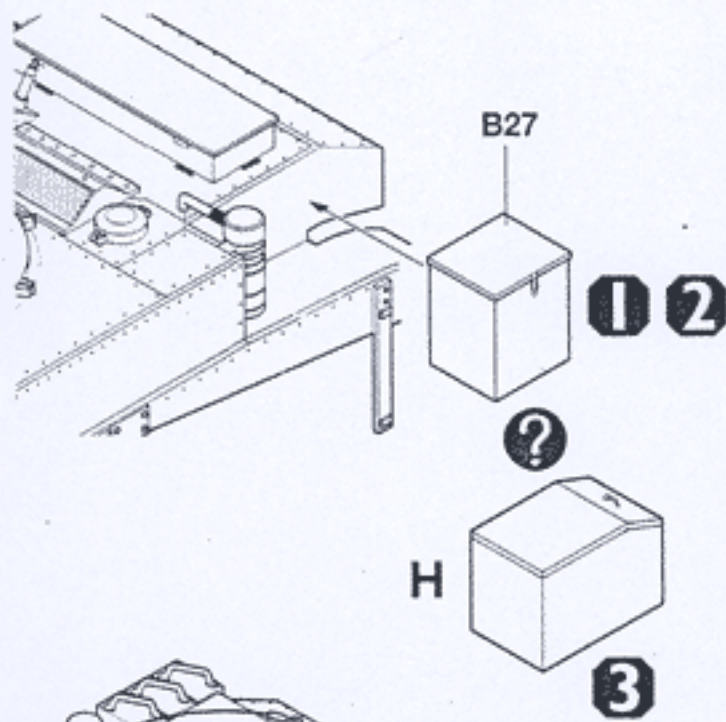
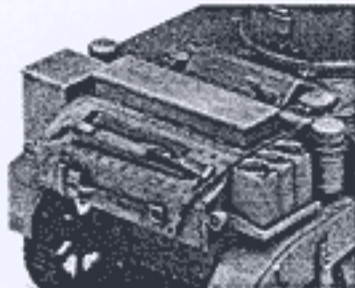
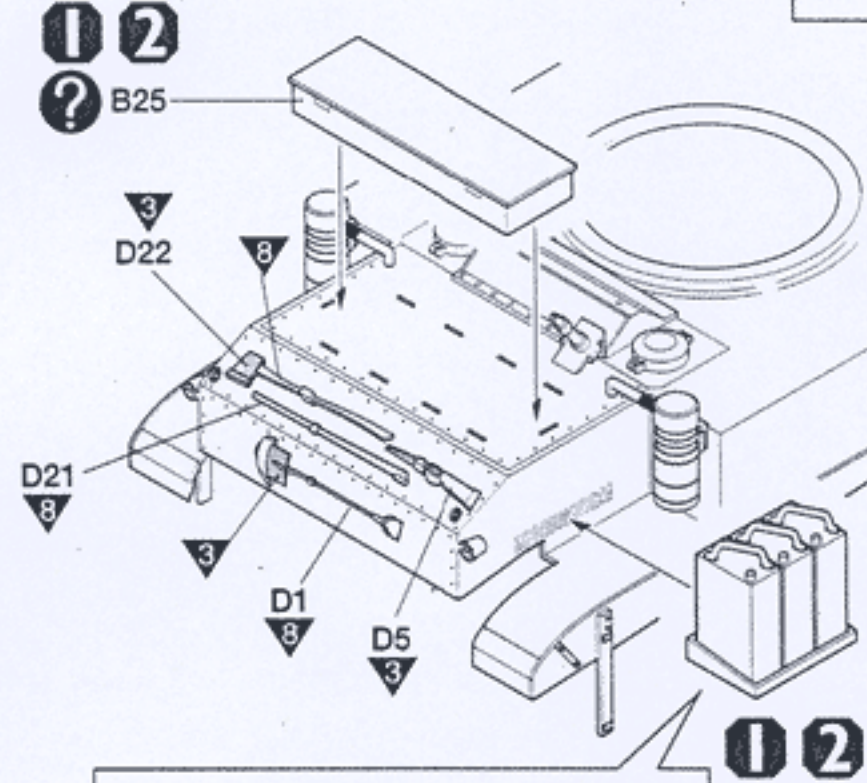

Melt pins heated screwdriver  
 불에 달군 드라이버로 핀의 끝을 살짝 녹인  
 후 바로 손가락으로 눌러 고정시킵니다.

Flexible Track  
 연결 캐터필러



7

INTERIOR COLOR :  
포함내부색

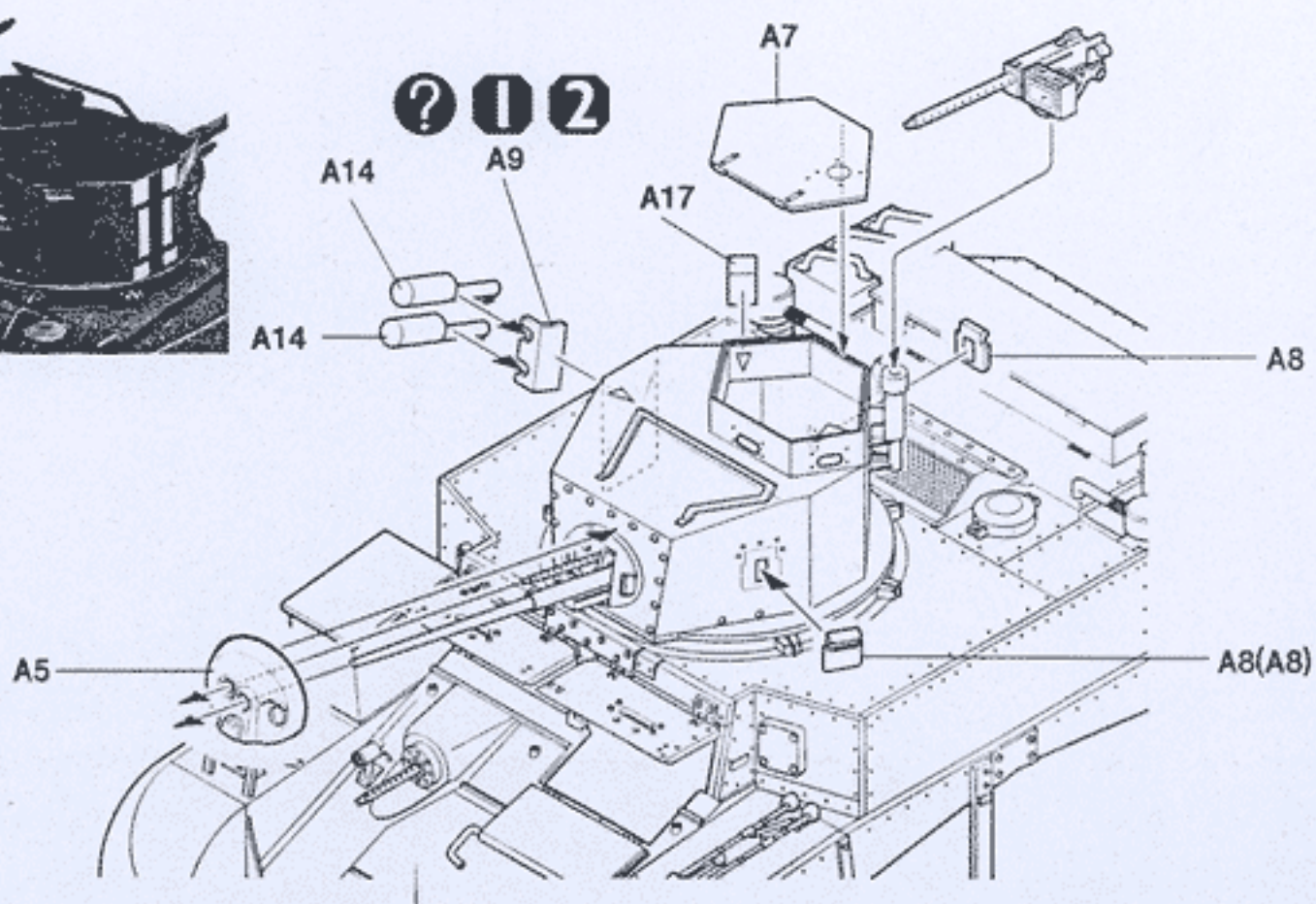
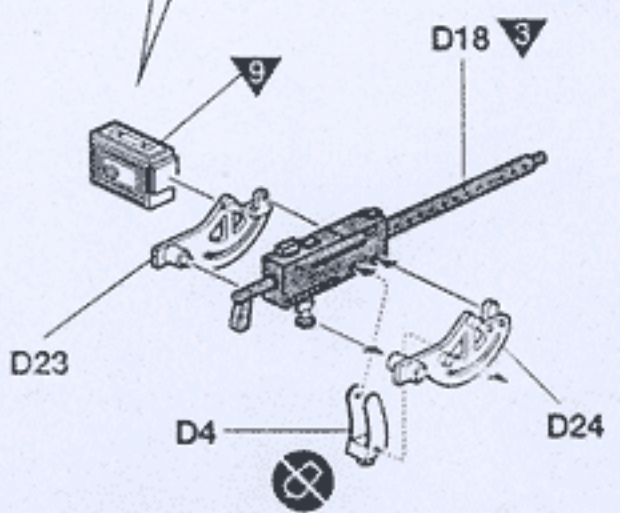
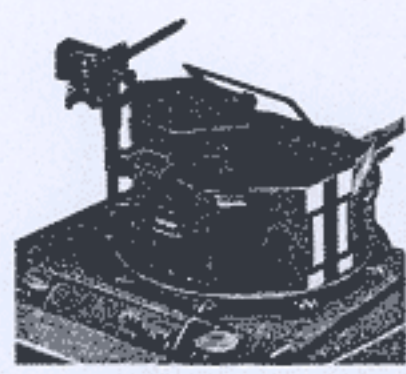
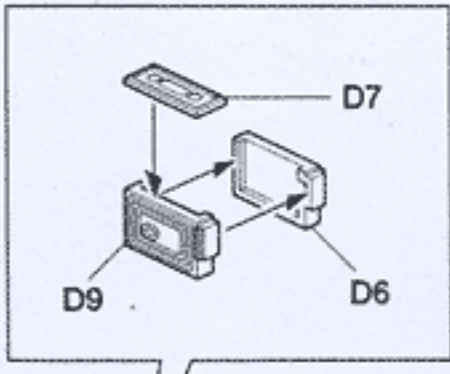
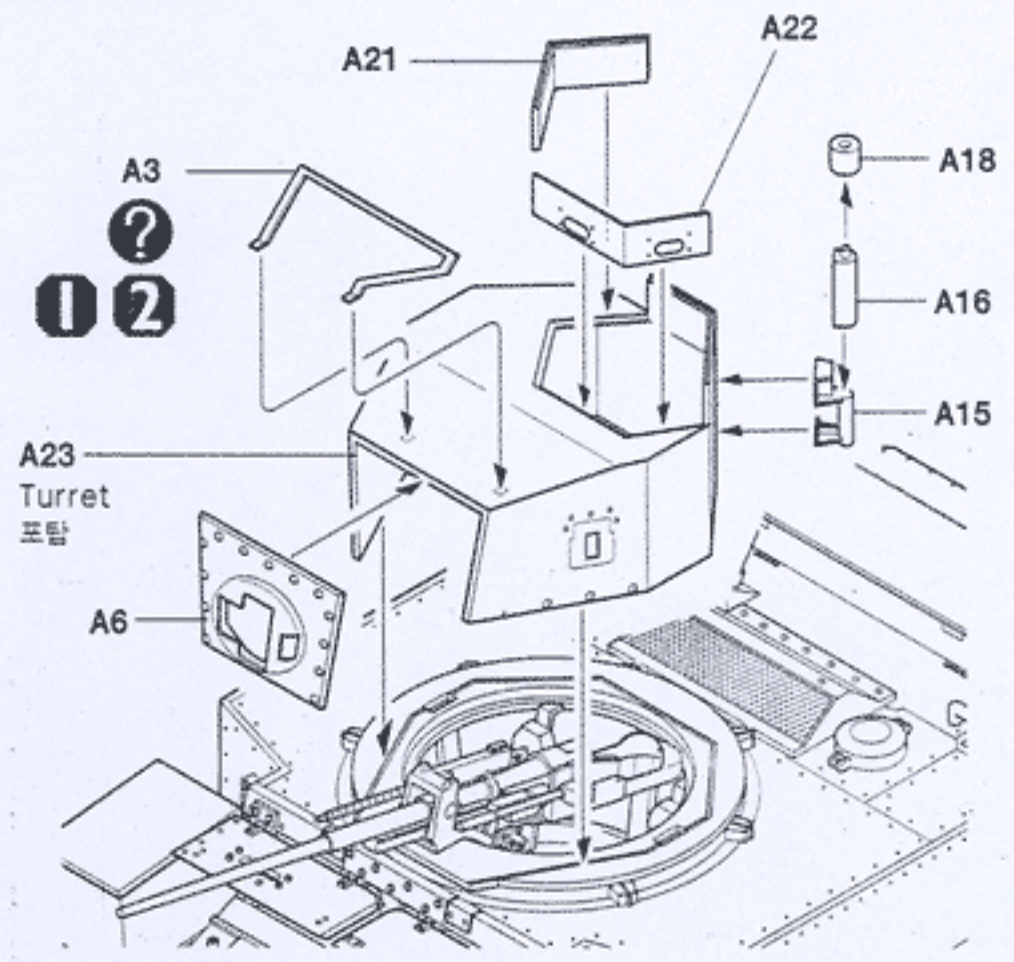
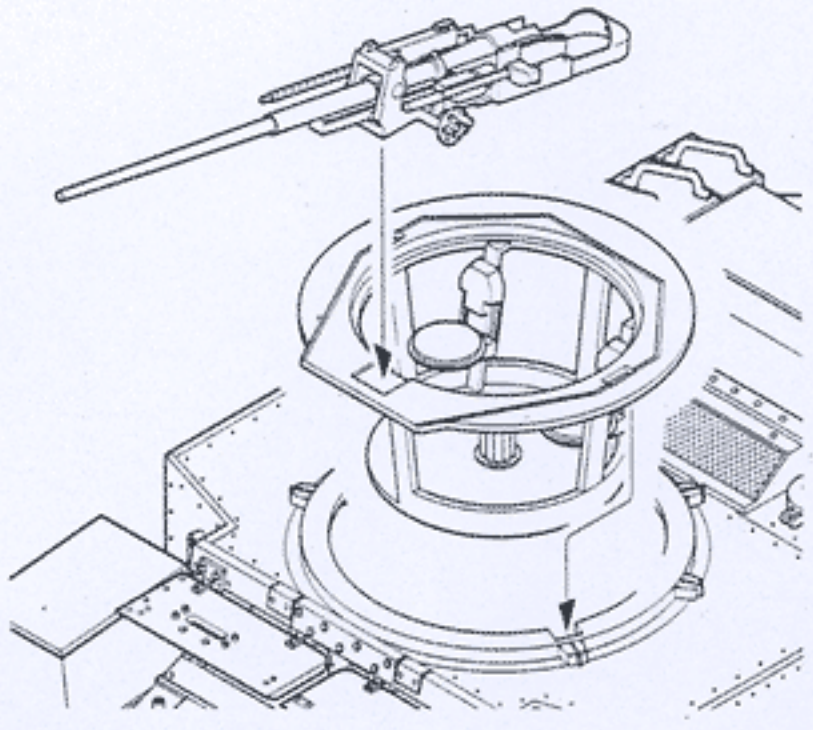
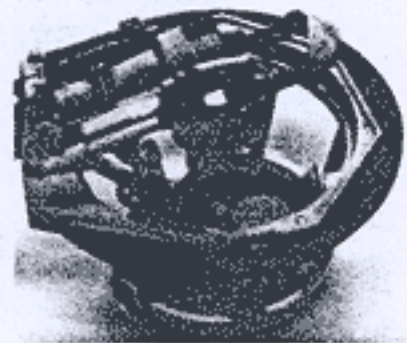
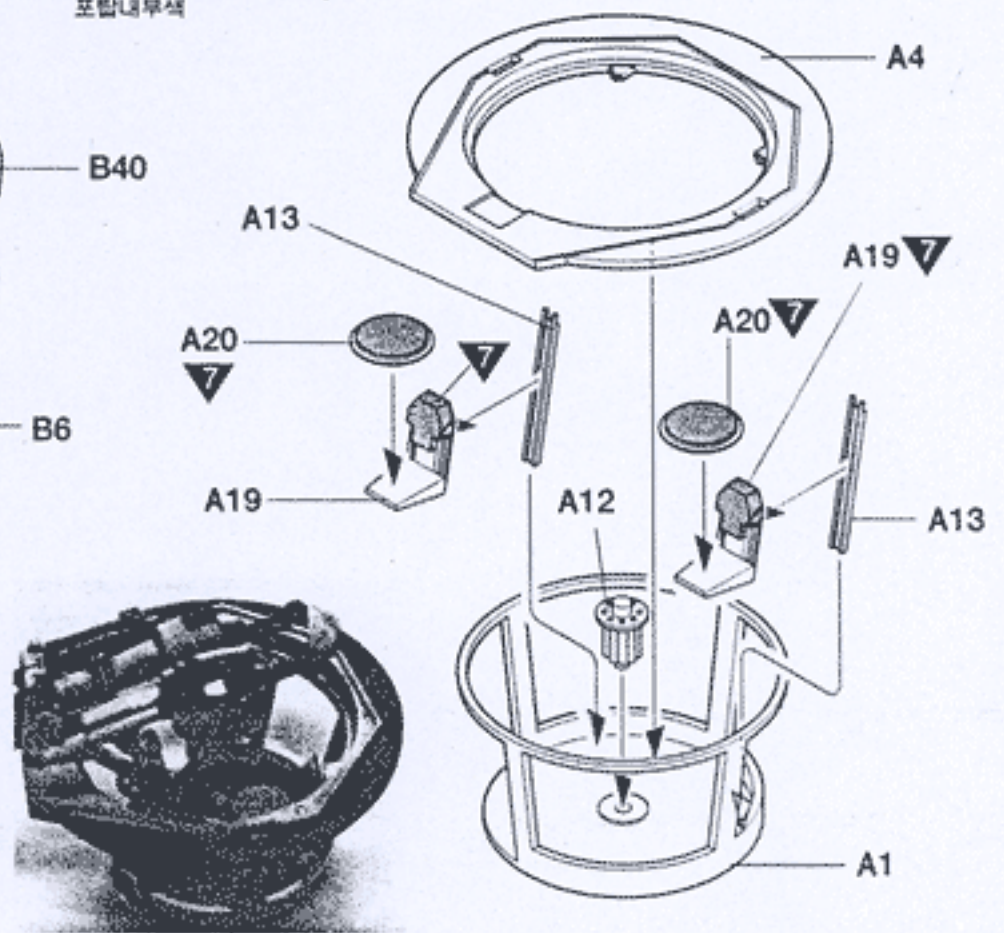
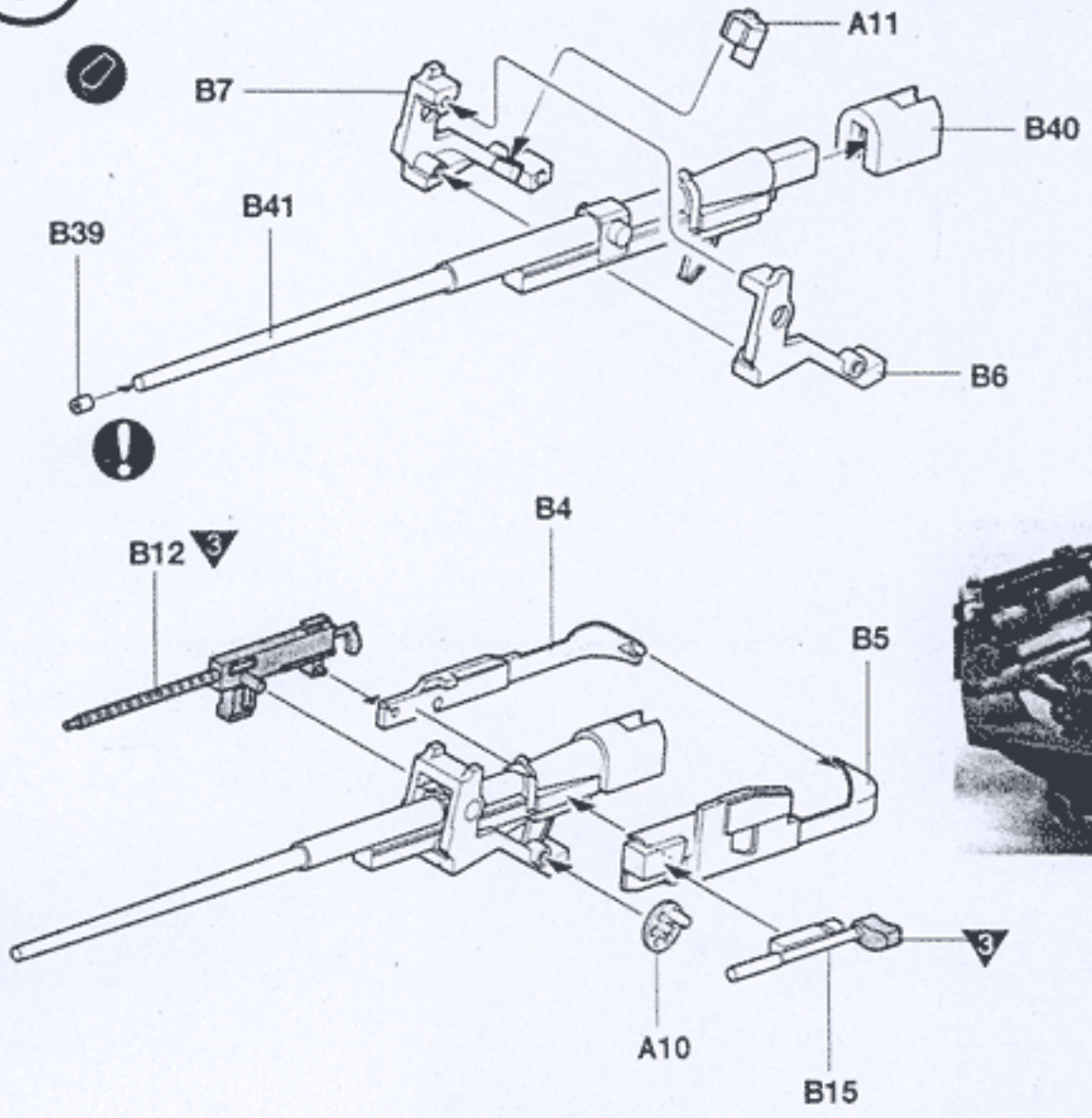



**1** "BELLMAN" 8th King's Royal Irish Hussars, 7th Armored Division, Bir-Hakeim, Lybia, May 1942  
 "벨맨" 영국 제7기갑사단 제8왕립 아이리쉬 연대, 비르 하케임, 1942년5월 리비아

TA991  
 /#1399

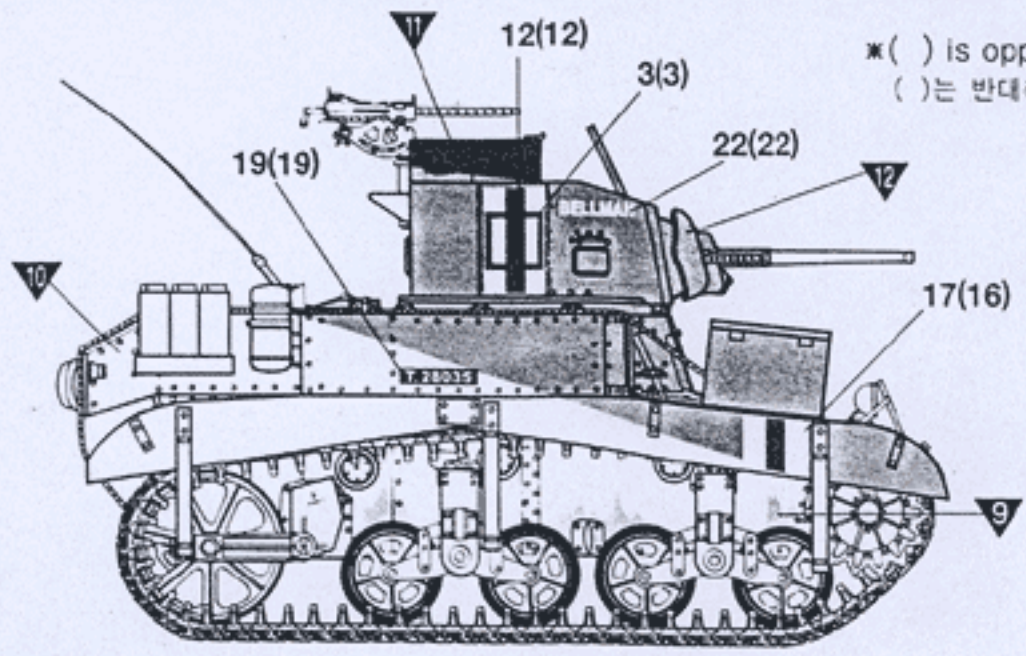

\* ( ) is opposite number.  
 ( )는 반대측 번호입니다.

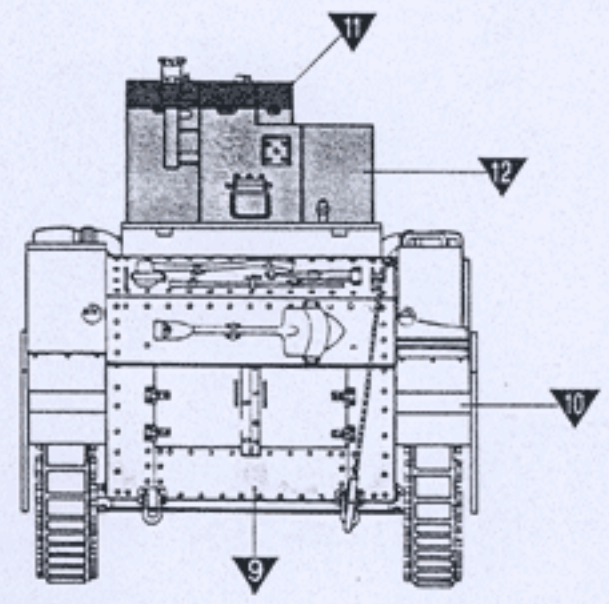
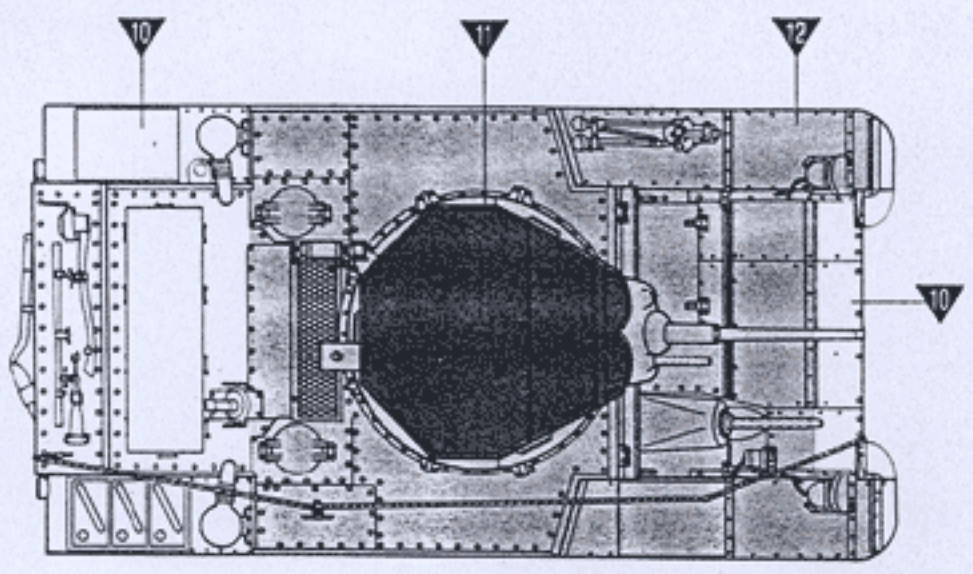
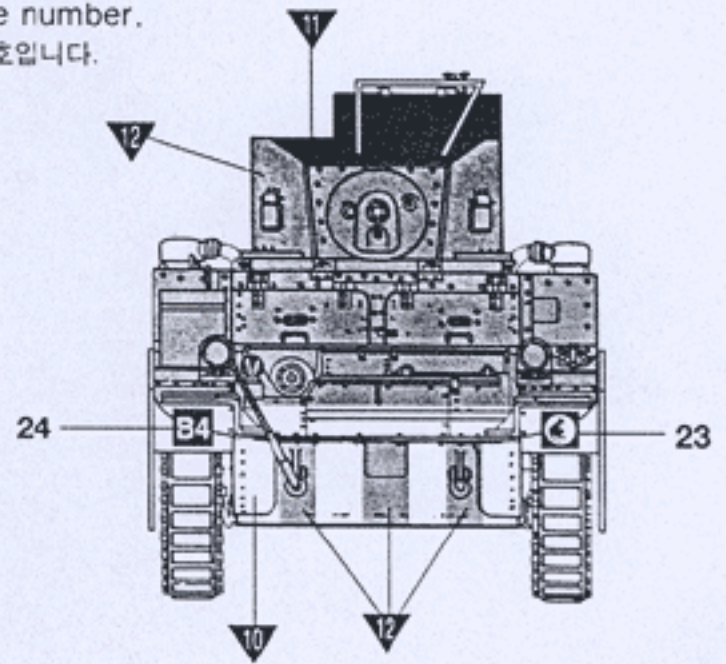

**2** 8th King's Royal Irish Hussars, 7th Armored Division, Sidi Rezegh, Libia, November 1941  
 영국 제7기갑사단 제8왕립 아이리쉬 연대, 시디 레제호, 1941년11월 리비아

\* 1,2,4,5,6,7,8,9 is unused.  
 1,2,4,5,6,7,8,9는 쓰이지 않습니다.

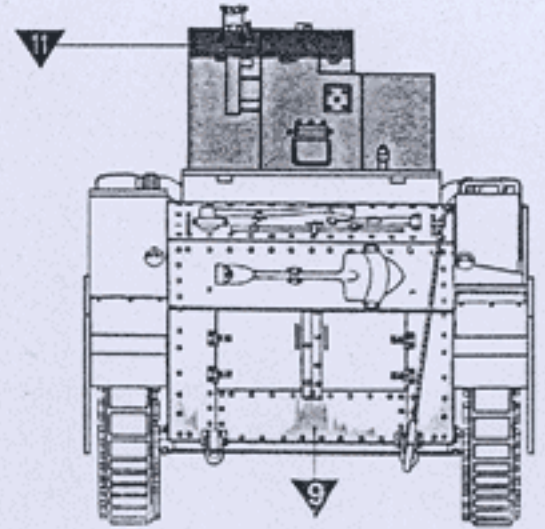
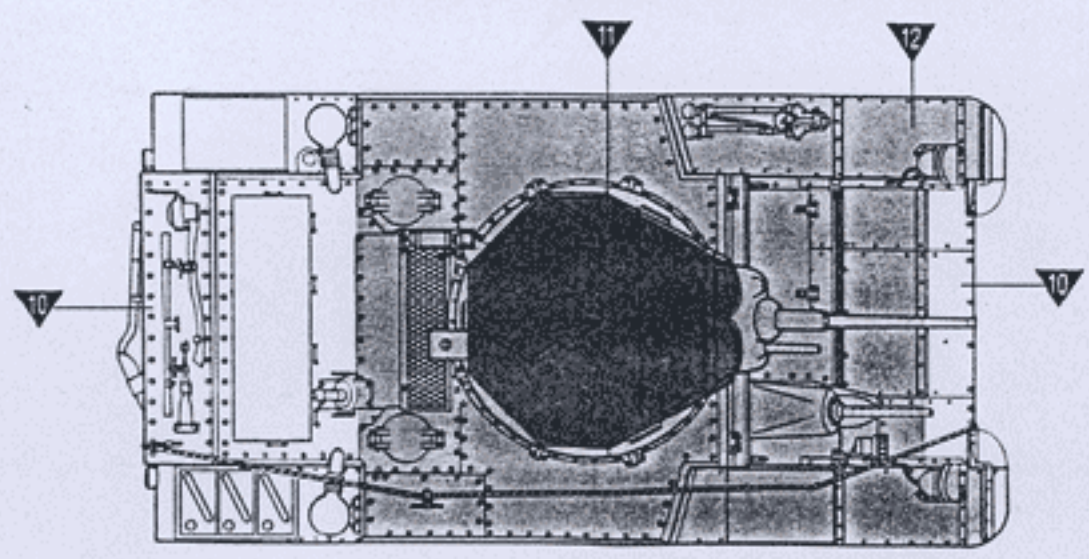
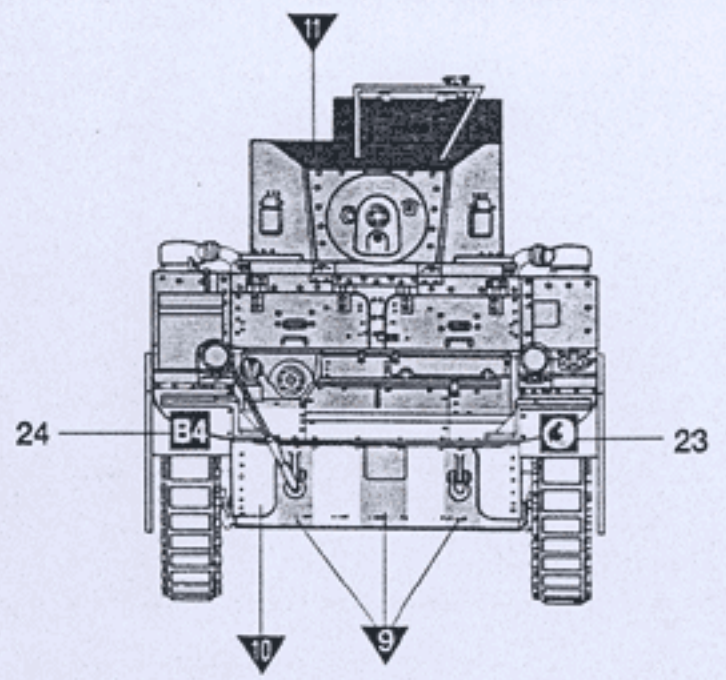
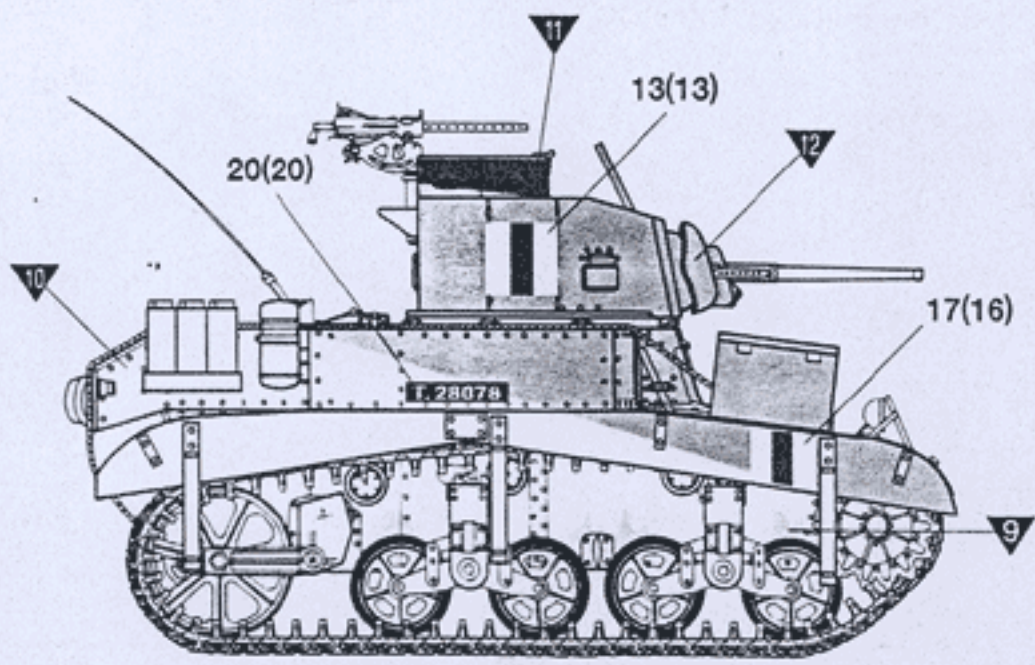



**3** 80th Armored Regiment, The Armored Force School, Fort Knox, Kentucky, June 1943  
 포트nox 기갑학교 제80기갑연대, 1943년 6월 미본토 켄터키주

\* ( ) is opposite number.  
 ( )는 반대측 번호입니다.

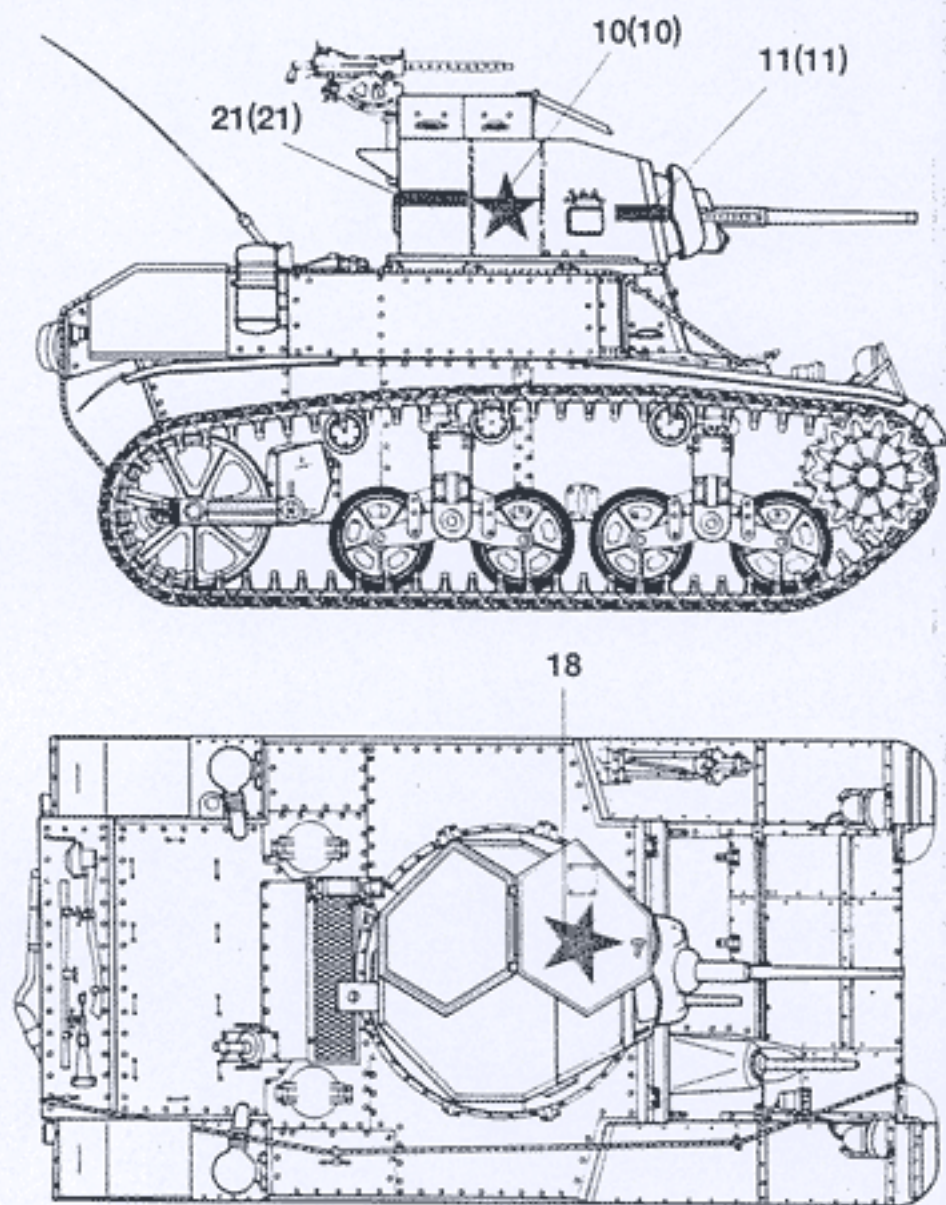

■ Body Color 차체색 : ▽9

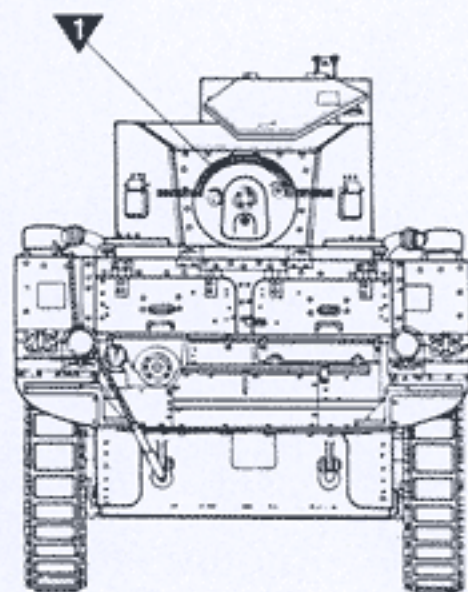

**4** Captured and use by the Imperial Japanese Army,  
 3rd Chutai, 7th Sensh Rentai, Manila, Philippines. May 1943  
 구일본육군 제7전차연대 제3중대 노획사용 차량, 1943년5월 필리핀 마닐라

■ Body Color 차체색 : ▽9

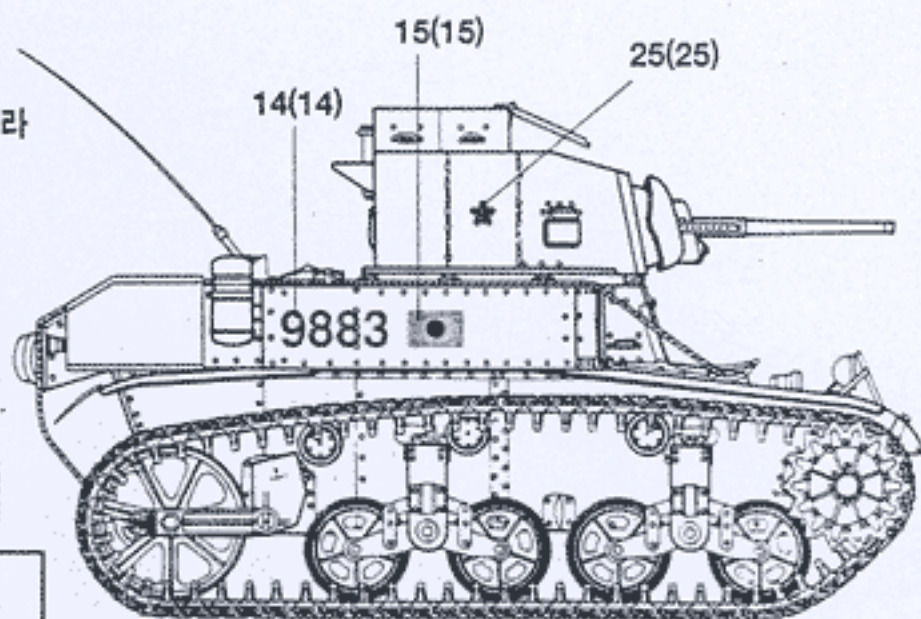

▽1	FLAT WHITE	MATTWEIß	BLANC MAT	つや消しホワイト	무광흰색
▽2	FLAT BLACK	MATTSCHWARZ	NOIR MAT	つや消しブラック	무광검정색
▽3	GUN METAL	METALL-GRAU	GRIS ACIER	ガンメタル	건예탈
▽4	SILVER	SILBER	ARGENT	シルバー	은색
▽5	GOLD	GOLD	OR	ゴールド	금색
▽6	RED	ROT	ROUGE	レッド	유광빨강색
▽7	KHAKI	KHAKI	KAKI	カーキ	카키색
▽8	LIGHT BROWN	HELLBRAUN	BRUN CLAIR	ライトブラウン	라이트브라운
▽9	OLIVE DRAB	BRAUNOLIV	VERT OLIVE	オリーブトラブ	국방색
▽10	DESERT YELLOW	SANDGELB	JAUNE DÉSERT	デザートイエロ-	데저트옐로우
▽11	DARK GREEN	DUNKELGRÜN	VERT FONCÉ	ダークグリーン	다크그린
▽12	SLATE GREY	SCHIEFERGRAU	GRIS ARDOISE	スレートグレイ	슬레이트그레이
▽13	LIGHT BLUE	HELLBLAU	BLEU CLAIR	ライトブルー	라이트블루
▽14	MEDIUM GREY	MITTELGRAU	GRIS MOYEN	ミディアムグレイ	미디엄그레이

■ 직배정 겸 A/S센터 삼선교: 742-9293, 방배동: 552-9293, 양재동: 575-9997, 용산: 796-1214, 아셈하이센터: 6002-6293.  
 ■ A/S센터 본사: 908-7000(교훈 147), 동대문: 745-9293  
 ■ 총판점 겸 A/S센터 원이카데미: 907-0940, 양천아카데미: 2691-7108, 강북아카데미: 762-0990, 강남아카데미: 485-6884  
 AB하이: (031)458-5591, 서면아카데미: (051)816-9773, 대구아카데미: (053)744-9293  
 ■ 유통사업부 아카데미피연디: 586-3293  
 ■ 홈페이지 http://www.academy.co.kr  
 ■ 고객상담문의 080-969-7000



ACADEMY PLASTIC MODEL CO., LTD.  
 273-64, Suyu-dong, Kangbuk-gu, Seoul, Korea  
 TEL: 82-2-908-7000 FAX: 82-2-997-3003



■ Parts Locating Diagram 부품도

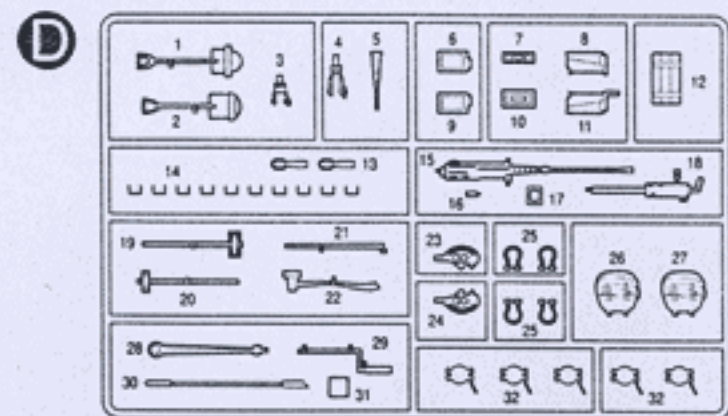
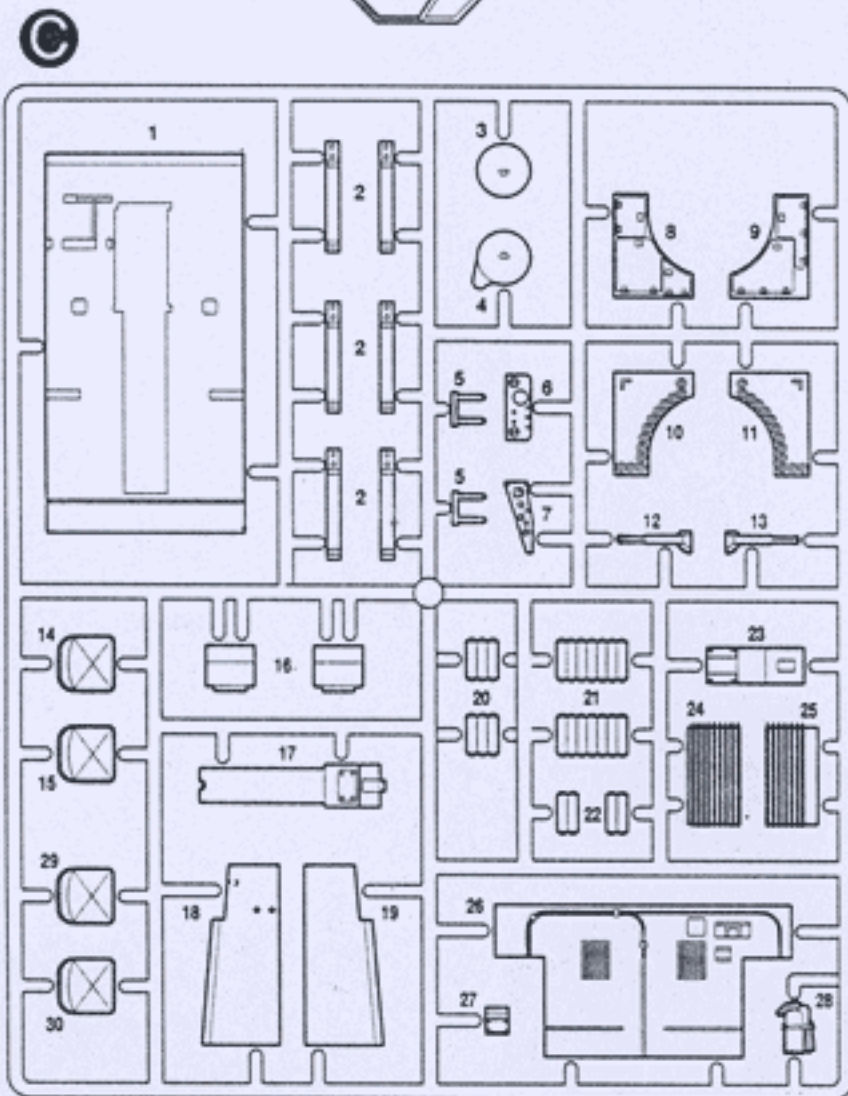
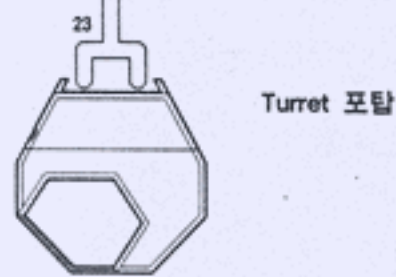
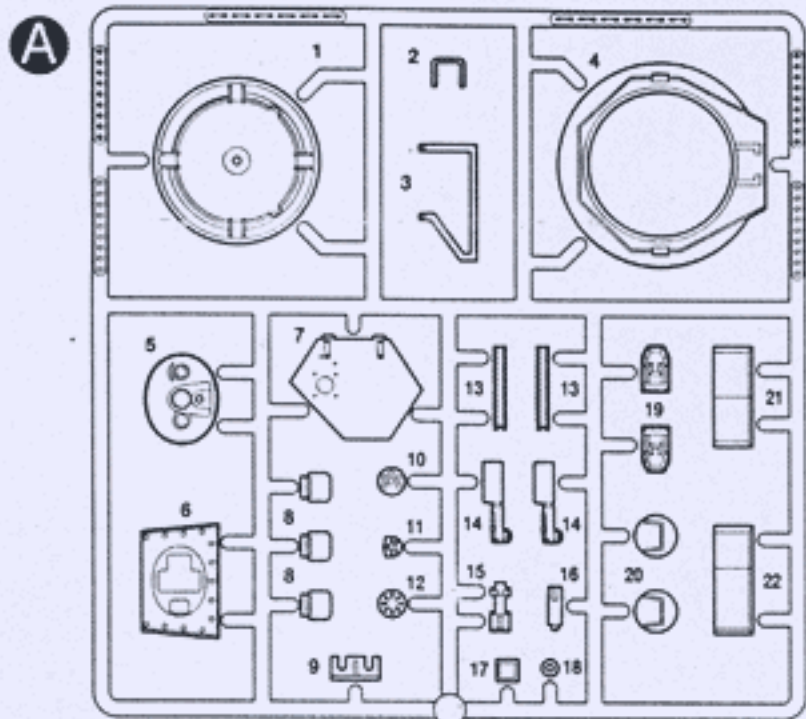

- Upper hull 상체 × 1
- Lower hull 하체 × 1
- Flexible Track 연결캐터필러 × 2
- Thread 실 × 1
- Decal 전사지 × 1

- 직매점 겸 A/S센터
  - A/S센터
  - 총판점 겸 A/S센터
  - 유통사업부
  - 홈페이지
  - 고객상담문의
- 삼성교: 742-9293, 방배동: 552-9293, 양재동: 575-9997,  
 용산: 796-1214, 아셈하비센터: 6002-6293  
 본사: 908-7000(교촌 147), 동대문: 745-9293  
 원아카데미: 907-0940, 양천아카데미: 2691-7108, 강북아카데미: 762-0980, 강남아카데미: 485-6884  
 AB하비: (031)458-5591, 서면아카데미: (051)816-9773, 대구아카데미: (053)744-9293  
 아카데미피렌디: 586-9293  
<http://www.academy.co.kr>  
 080-963-7000

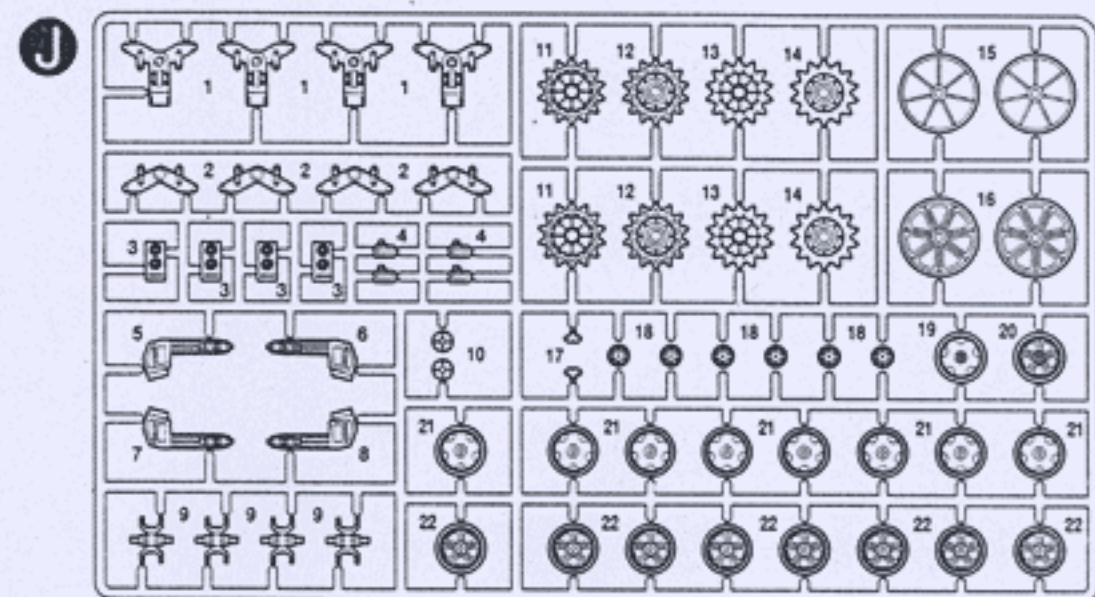
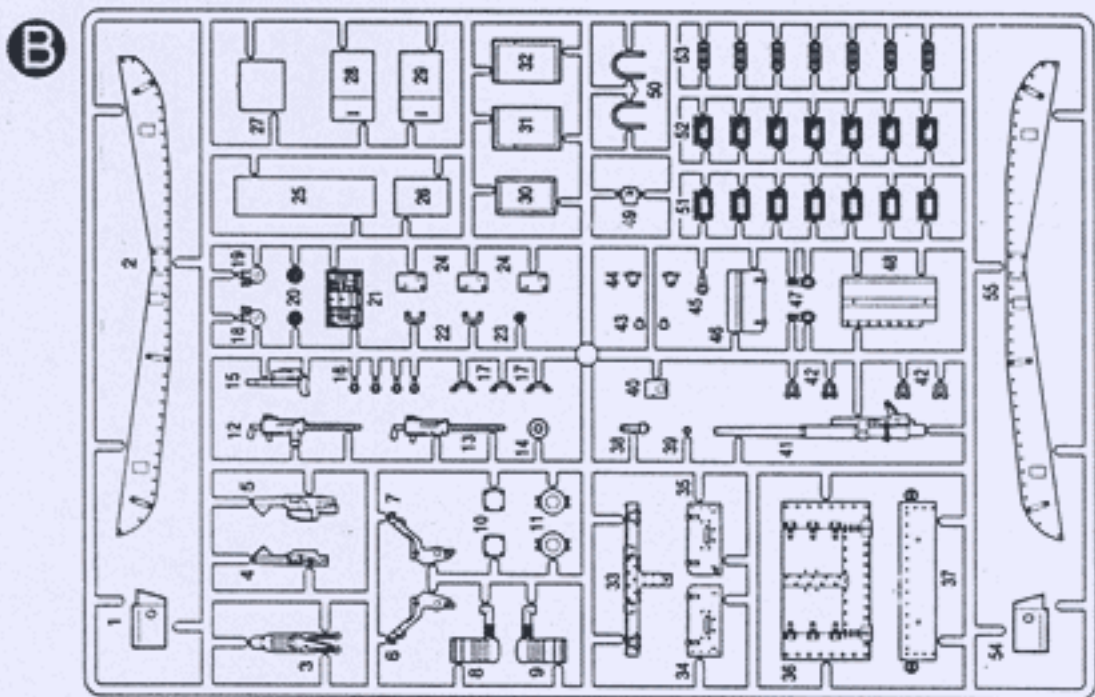

● × 2

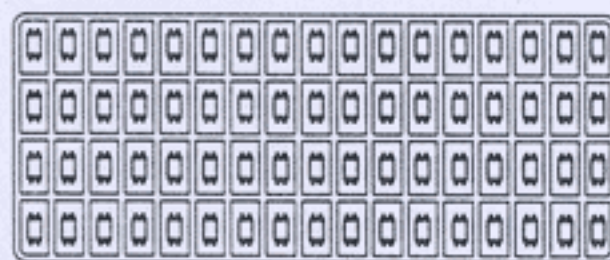

● × 2

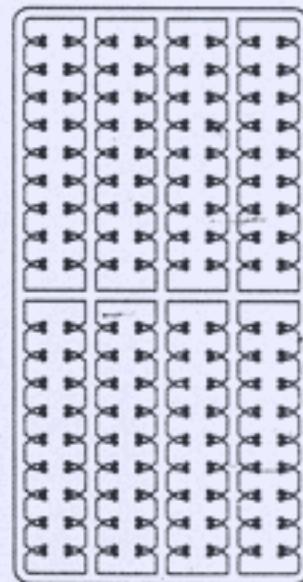

- Unused parts : B16 × 2, D2, D3, D8, D10, D11, D13, D14 × 6, D15, D16, D17, D19, D20, D25, D28, D29, D30, D31, D32, J13, J14, J15, J19, J21
- Accessory parts : D12, D26, D27, J20

1	FLAT WHITE	MATTWEIß	BLANC MAT	つや消しホワイト	무광흰색
2	FLAT BLACK	MATTSCHWARZ	NOIR MAT	つや消しブラック	무광 검정색
3	GUN METAL	METALL-GRAU	GRIS ACIER	ガンメタル	건메탈
4	SILVER	SILBER	ARGENT	シルバー	은색
5	GOLD	GOLD	OR	ゴールド	금색
6	RED	ROT	ROUGE	レッド	유광빨강색
7	KHAKI	KHAKI	KAKI	カーキ	카키색
8	LIGHT BROWN	HELLBRAUN	BRUN CLAIR	ライトブラウン	라이트브라운
9	OLIVE DRAB	BRAUNCLIV	VERT OLIVE	オリーブトラブ	국방색
10	DESERT YELLOW	SANDGELB	JAUNE DÉSSERT	デザ-トイエロ-	데저트옐로우
11	DARK GREEN	DUNKELGRÜN	VERT FONCÉ	ダ-クグリーン	다크그린
12	SLATE GREY	SCHIEFERGRAU	GRIS ARDOISE	スレートグレイ	슬레이트그레이
13	LIGHT BLUE	HELLBLAU	BLEU CLAIR	ライトブルー	라이트블루
14	MEDIUM GREY	MITTELGRAU	GRIS MOYEN	ミディアムグレイ	미디엄그레이



ACADEMY PLASTIC MODEL CO., LTD  
 273-64, Suyu-dong, Kangbuk-gu, Seoul, Korea  
 TEL: 82-2-908-7000 FAX: 82-2-907-3003