

ACADEMY

HOBBY MODEL KITS

TA979



독일육군 중전차 타이거-1 초기형

1/35TH SCALE

GERMAN HEAVY TANK TIGER-1 EARLY VERSION

TECHNICAL SPECIFICATION

성능 및 제원

WEIGHT

*Combat weight : 56.9 tons
*Transport weight : 44.6 tons

DIMENSIONS

*Length overall : 8.24 m (27' - 9")
*Hull length : 6.20 m (20' - 8 1/2")
*Width : 3.07 m (12' - 10")
*Height : 3.00 m (9' - 10")

TRACKWORK

*Type : Single line
*Centers : 2.82 m (9' - 3 1/2")
*Width : 0.725 m (28 1/2")

MAIN ARMAMENT

1 x 88 mm (3.46 ins.) KwK 36 L/56
*Traverse : 360°
*Operation : 2 speed, hydraulic & hand
*Elevation : + 17°, - 6.5°

SECONDARY ARMAMENT

1 x 7.92 mm MG 34 co-axial
1 x 7.92 mm MG 34 bow
1 x 9 mm MP 38/40
1 x 27 mm WALTHER Signal pistol

AMMUNITION

*88 mm AP & HE : 92 rds.
*7.92 mm : 5,700 rds. (38 belts 150 rds.)

ENGINE

1 x MAYBACH HL-210-P45 V-12
Cylinder Watercooled Gasoline of
21,353cc developing 642 bhp at 3,000
r.p.m.

TRANSMISSION

*MAYBACH-OLVAR 40 12 16
Preselective, 8 forward 4 reverse.

STEERING UNIT

*HENSCHEL L600C Regenerative
controlled differential, hydraulic
operated.

SUSPENSION

*Torsion bar, Hydraulic shock absorbers
on front & rear axle, housed in hull.

FUEL CAPACITY

*534 liters (125 Imp.gals. / 141 U.S.gals.)
*Fuel consumption (100 km) :
Road - 500 ltrs. Cross country - 900 ltrs.

PERFORMANCE

*Max speed (Road) : 38 km/h
(23 mph)
*Max speed (Cross country) : 20 km/h
(12 mph)
*Range (Road) : 117 km (73 miles)
*Range (Cross country) : 67 km (42 miles)
*Fording depth (first 495 vehicles) :
3.96 m (13' - 0")
*Fording depth (remainder) :
1.2 m (3' - 11")
*Max gradient : 35° (70%)
*Trench crossing : 1.8 m (5' 11")

ARMOR

*Type : Rolled homogenous plate inter-
locking stepped joints welded construction.
*Thickness : 26 ~ 110 mm

SIGHTING

*Main armament : 1 x TZF 9B binocular
telescope
*Commander : 5 x vision slits in barrel
type cupola

CREW

*5 men - commander, gunner, loader,
driver, radio operator/MG gunner

PRODUCTION

*Manufacturer : HENSCHEL Werke.
*A total of 1,354 vehicles in Aug. 1942
until Aug. 1944.

중량

*전투 중량 : 56.9톤
*차체 중량 : 44.6톤

길이

*전장 : 8.24 m
*차체장 : 6.20 m
*전폭 : 3.07 m
*전고 : 3.00 m

캐터필러

*형식 : 싱글핀 방식
*중심선간 거리 : 2.82 m
*폭 : 0.725 m

주무장

88 mm KwK 36 L/56 1문
*선회각 : 360°
*조작 : 2단 변속, 유압 및 수동식
*앙각(仰角) : + 17°, - 6.5°

부무장

*7.92 mm MG 34 동축 기관총 1정
*7.92 mm MG 34 전면 기관총 1정
*9 mm MP 38/40 자동 소총 1정
*27 mm 월터 신호 권총 1정

탄약

*88 mm 성형 작약탄 및 고풍탄 : 92발
*7.92 mm 5700발(150발들이 탄띠 38개)

엔진

*마이바하 HL-210-P45 12기통 가솔린 엔진.
배기량 21,353 cc - 3,000회전 642마력

트랜스미션

*마이바하-올바 40 12 16 가변 연동식, 전
진 8단 - 후진 4단

조항장치

*헨셀 L600C 디퍼런셜 복렬 유압 조종식
서스펜션
*토션바 형식, 차체 내측 전,후 액셀에 쇼
크 압소버 장착

연료적재량

*534 리터 (141 갤런)
*연료 소모량 (100km기준) :
도로 - 500 리터, 야지 - 900 리터

기동성

*최대 속도(도로) : 38 km/h
*최대 속도(야지) : 20 km/h
*행동 거리(도로) : 117 km
*행동 거리(야지) : 67 km
*도하 수심(양산 495대까지) : 3.96m
*도하 수심(중,후기형) : 1.2m
*등판 각도 : 35° (70%)
*초호(超濶) 반경 : 1.8m

장갑

*형식 : 주조 및 압연균질 방탄장갑
*두께 : 26 ~ 110 mm

조준장치

*주무장 : TZF 9B 쌍안 망원경 1기
*전차장 큐포라 : 슬릿형 잠망경 5기

승무원

*5명 - 전차장, 포수, 조준수, 조종수,
무선수/기관총 사수

생산

*제조 회사 : 헨셀 중기
*1942년 8월부터 1944년 8월까지 총 1,354
대 생산.

#1348

■ 조립하기전에

- 제품을 조립하기전에 설명서를 끝까지 잘 읽어본다.
- 부품을 자를때에는 칼이나 니퍼로 깨끗이 잘라준다.
- 접착하기전에 부품을 맞추어 확인한 후 접착한다.
- 접착제를 사용할 곳과 사용하지않는 곳에 주의하고 너무 많이 바르지 않도록 한다.
- 에나멜 페인트나 접착제를 사용할때에는 창문을 열어 환기를 시키고 화기를 멀리한다.

- 직매점 겸 A/S센터
- A/S센터
- 총판점 겸 A/S센터
- 유통사업부
- 홈페이지
- 고객상담문의

삼선교: 742-9293, 방배동: 552-9293, 양재동: 575-9997, 용산: 796-1214, 아셈하이센티: 6002-6293,
 본사: 908-7000(교한 147), 동대문: 745-9293
 원아카데미: 907-0940, 양천아카데미: 2691-7108, 강북아카데미: 762-0980, 강남아카데미: 485-6884
 AB하비: (031)458-5591, 서면아카데미: (051)816-9773, 대구아카데미: (053)744-9293
유통사업부: 904-0000
 http://www.academy.co.kr
 080-969-7000

1

→ 접착한다. CEMENT ●---▶ 접착금지. DO NOT CEMENT
 ※ ()는 반대측 부품 번호임. () is opposite number.

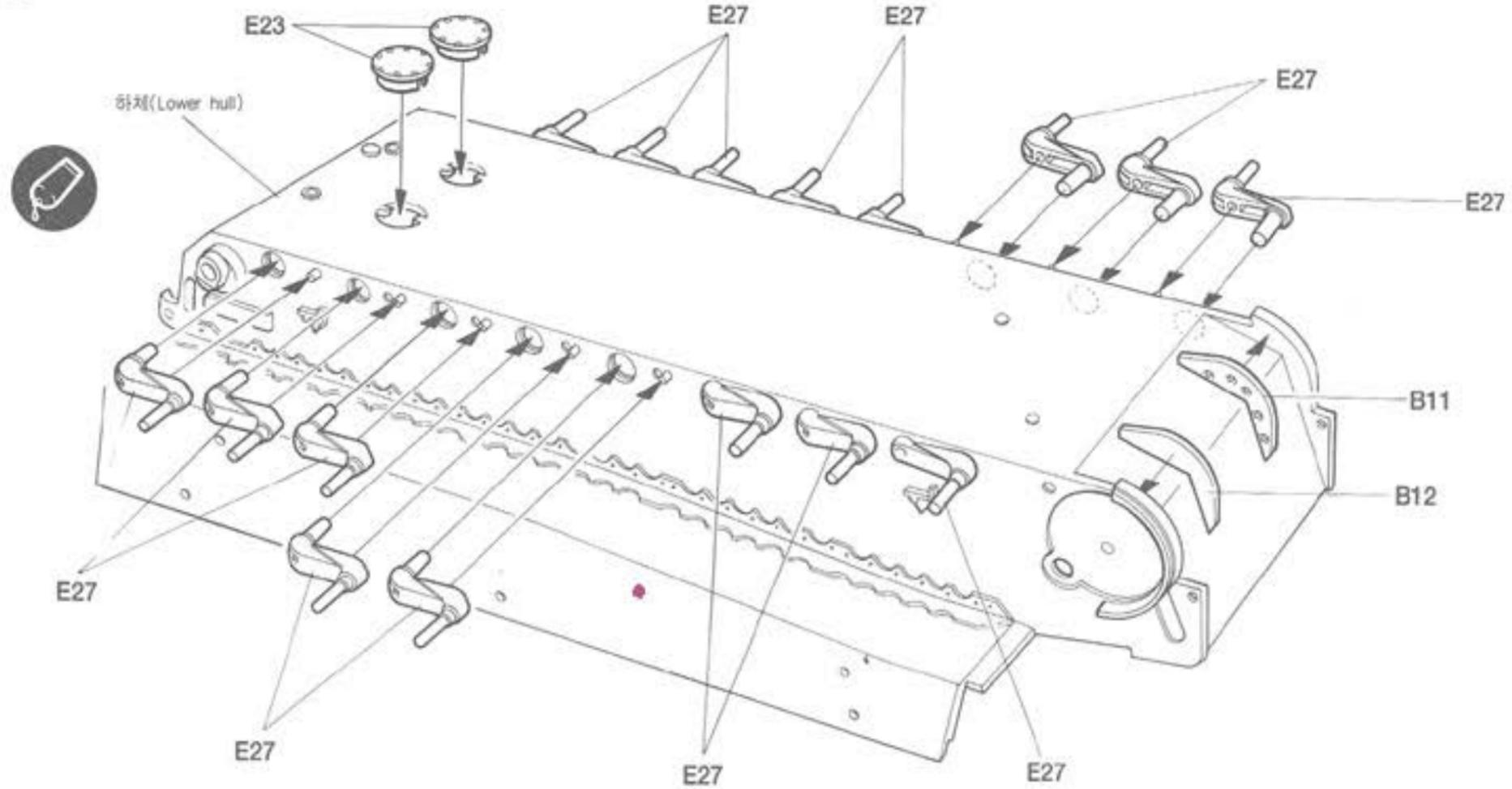

2

A 전륜 (Road wheel)

B 전륜 (Road wheel)

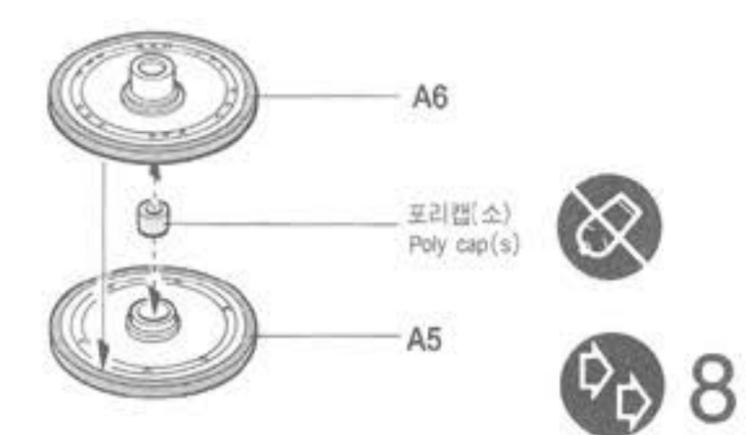
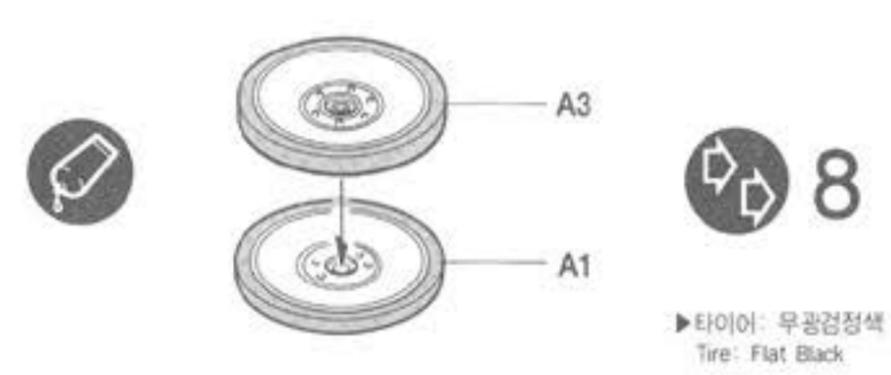

C 아이들러 휠 (Idler wheel)

D 기동륜 (Drive sprocket)

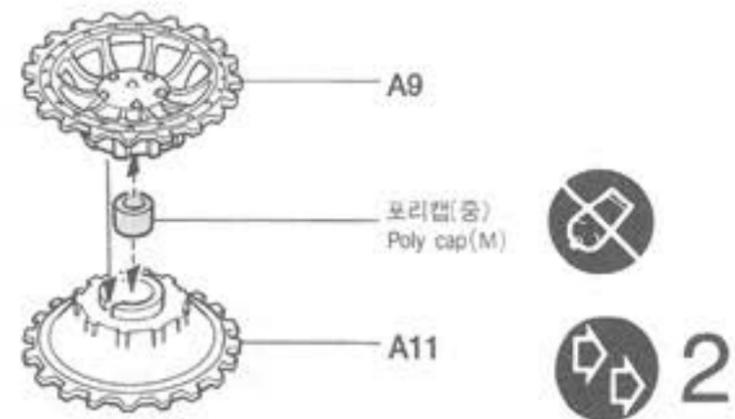
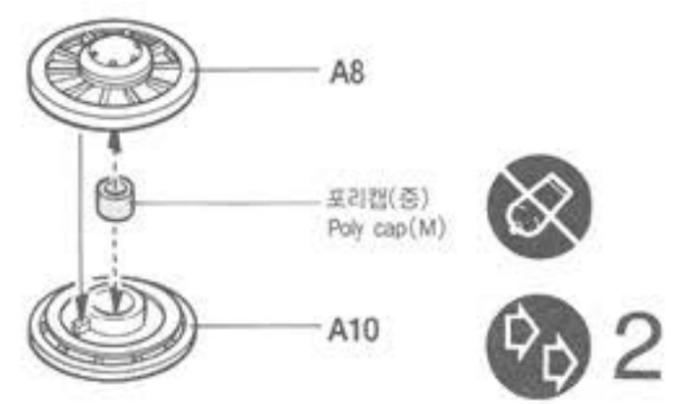

 <p>접착한다. Cement Parts Coler Kleben Pagar Incollare Colar Kleven</p>	 <p>접착하지 않는다. DO NOT cement No gas coler Nicht kleben No pegar Non incollare Nao colar Niet kleven</p>	 <p>잘라낸다. Cut away Couper scheiden Cortar Tagliare Cortar Snijden</p>	 <p>선택한다. Optional parts Choix Auswahlmöglichkeit Eleccion Scelta Opcao Keuze</p>	 <p>수반를 보립한다. Repeat operation Répéter l'opération Vorgang wiederholen Ripetire la operacon Ripetere Repitir a operacao Herhalen</p>
--	---	--	--	---

3

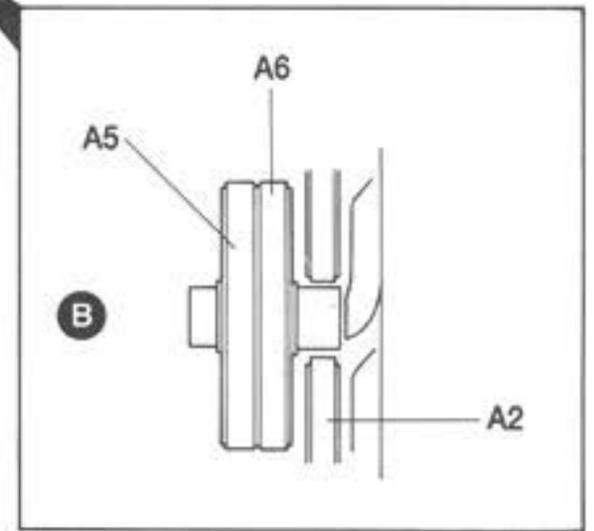
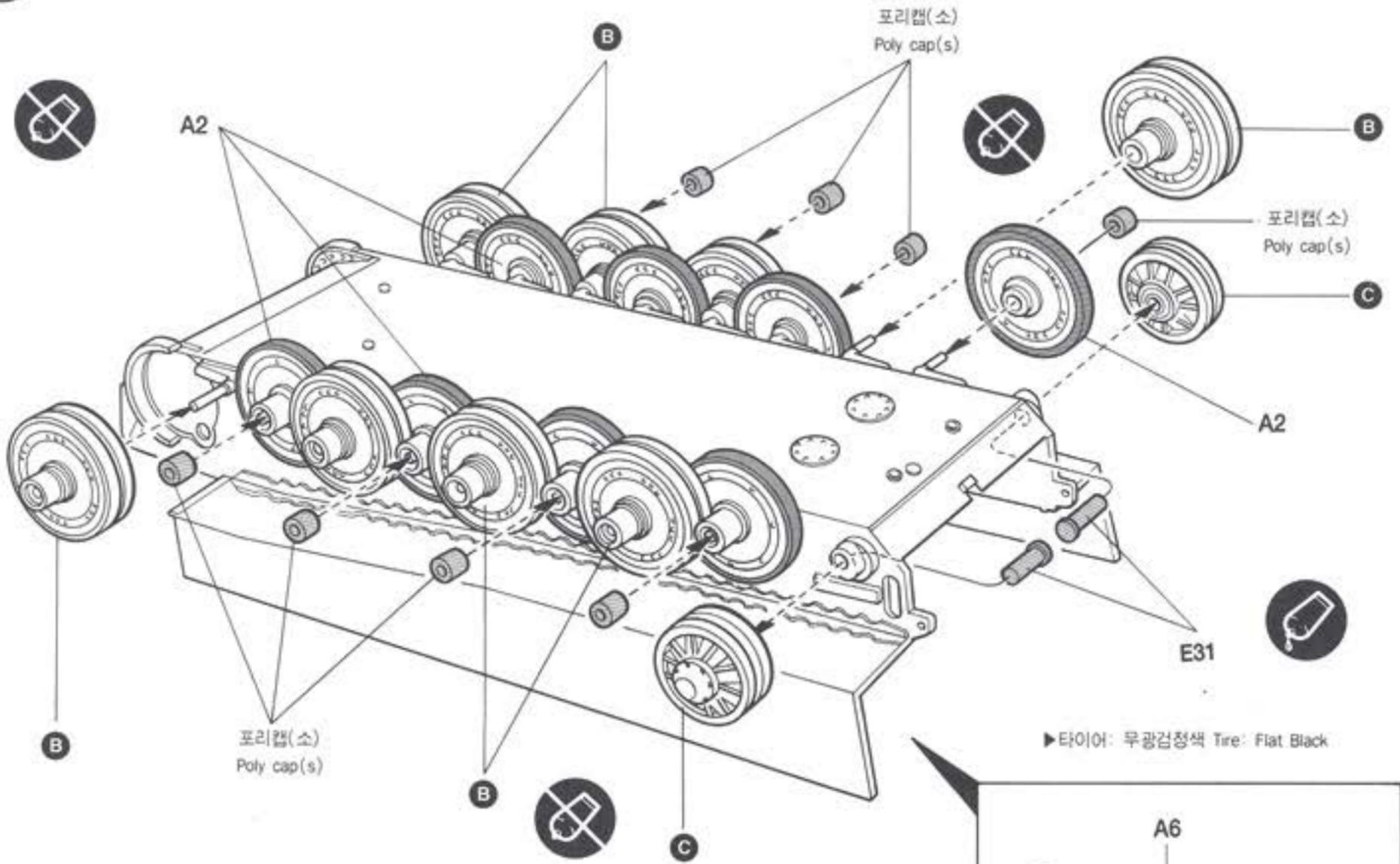

4

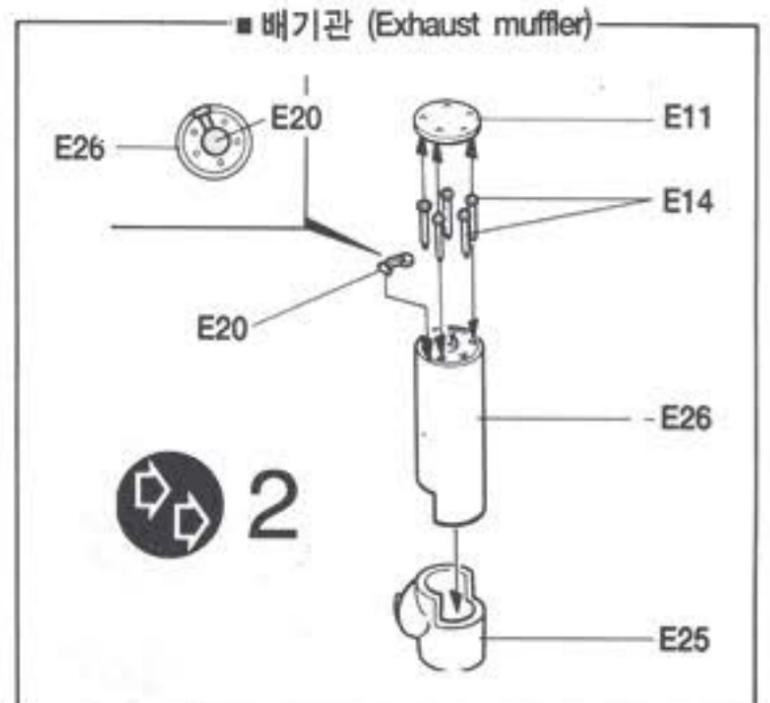
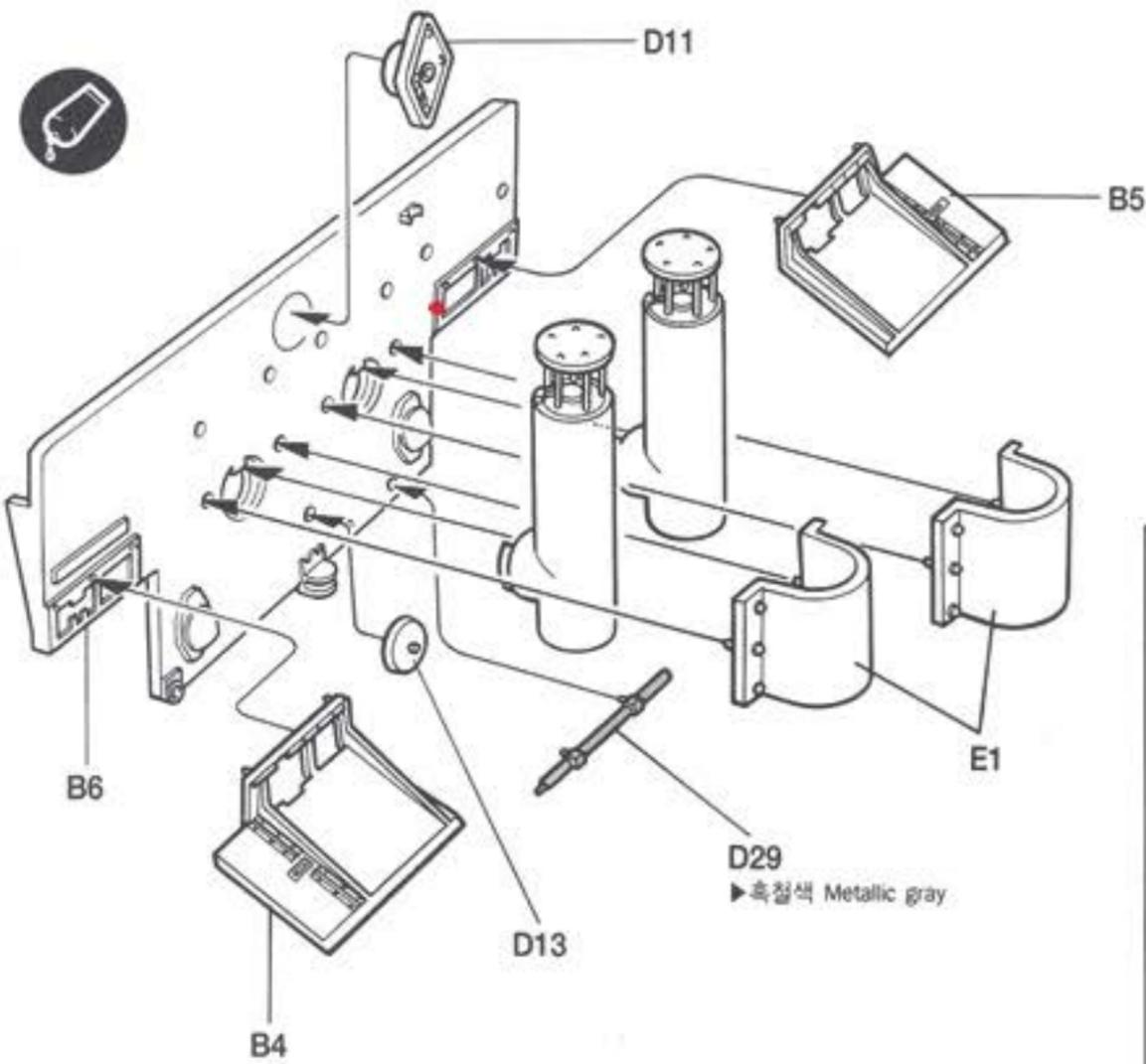

5

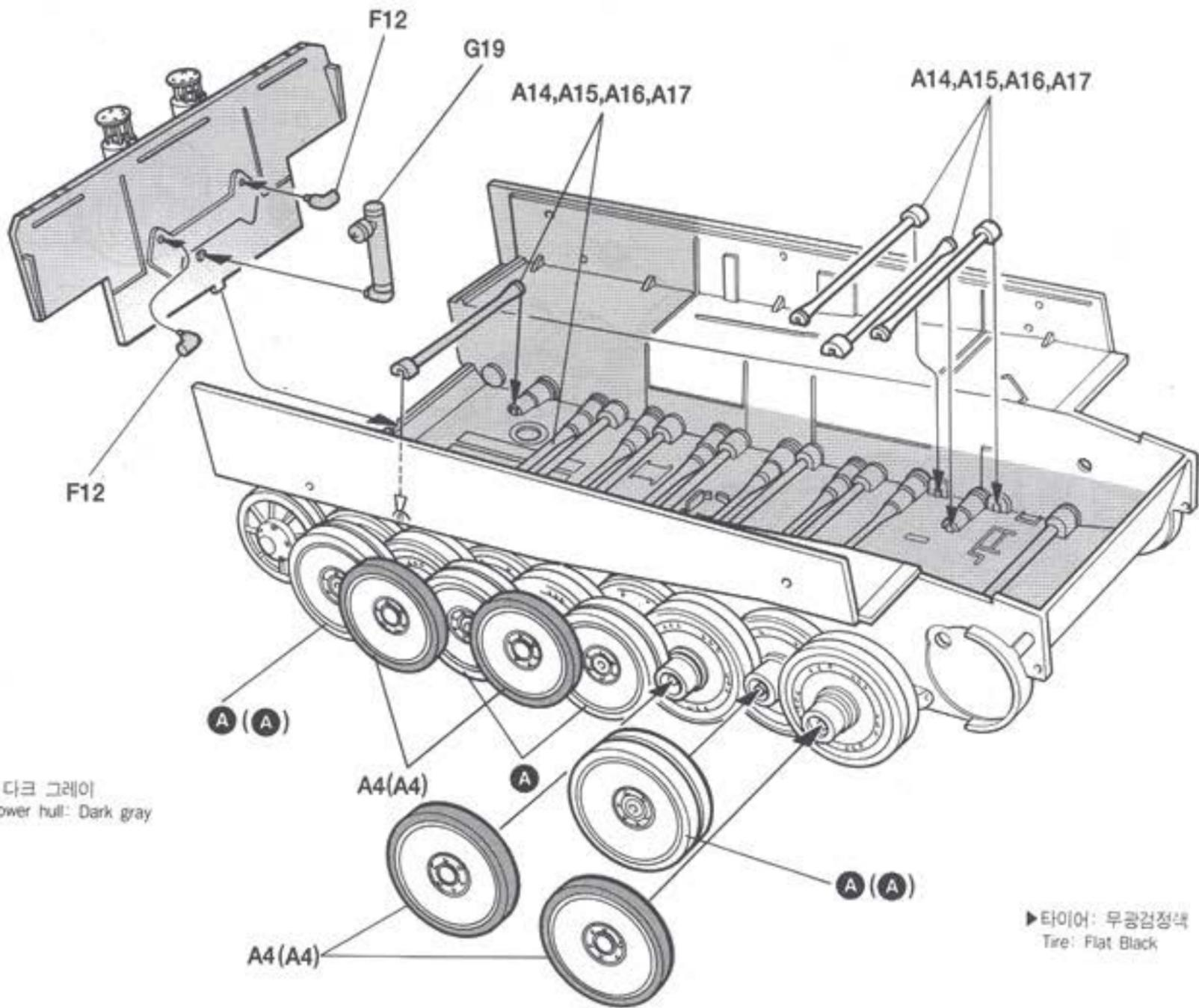

6

■ 파이펠 에어필터(Feifel air filter)

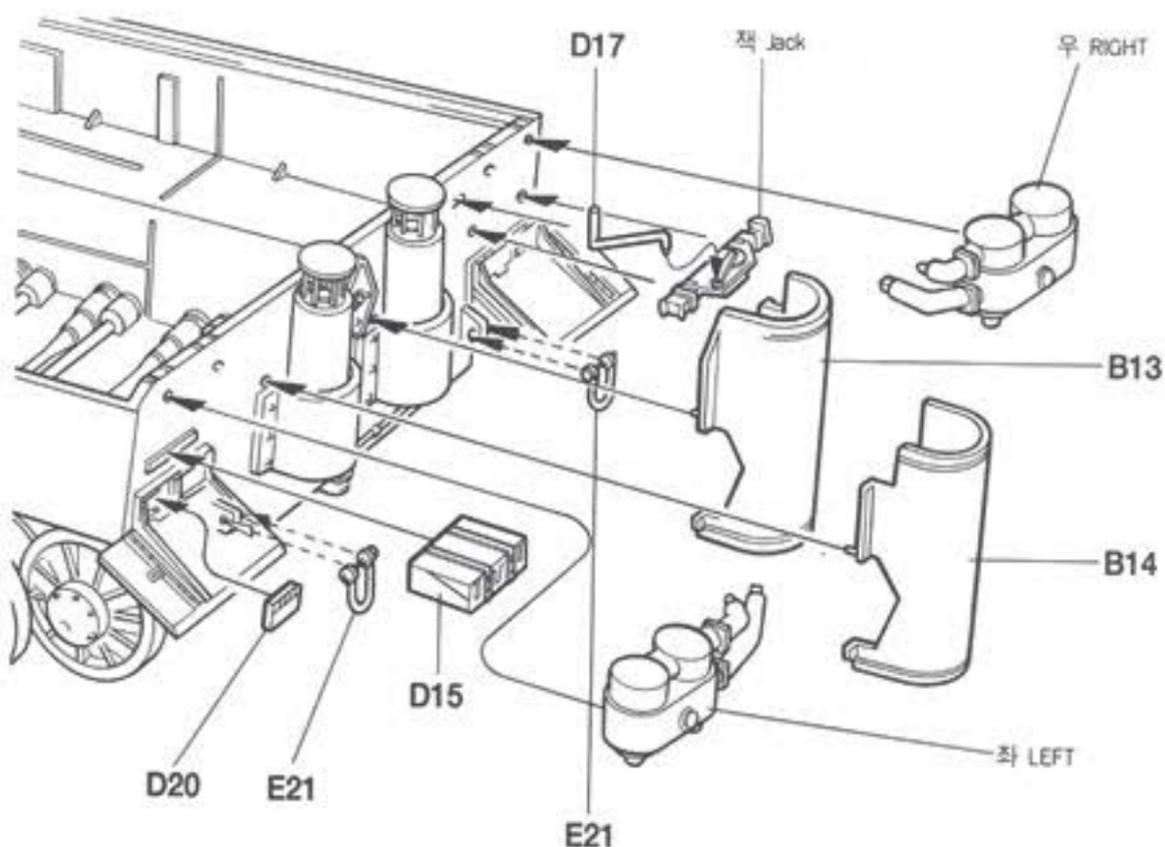
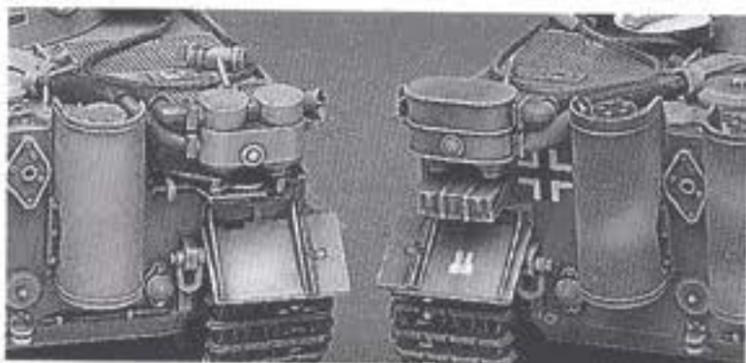
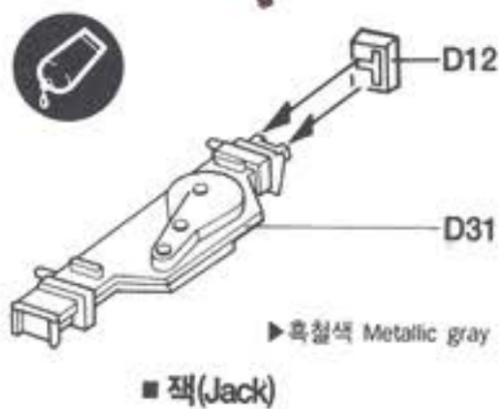
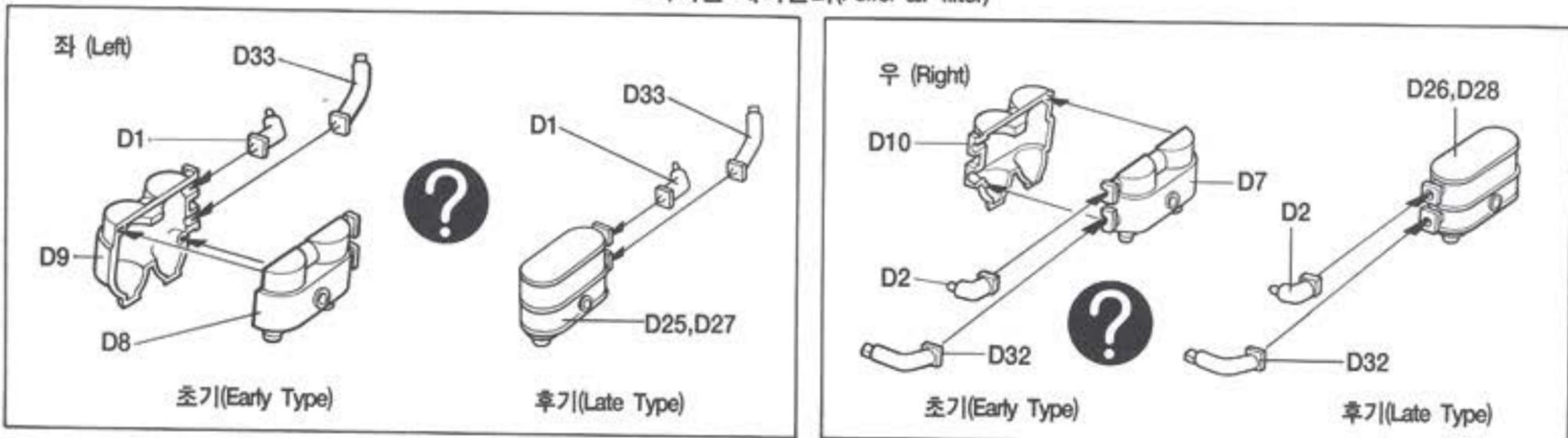

7

■ 마이바하 HL-210-P45 엔진(Maybach HL-210-P45 Engine)

▶전체: 흑철색 Overall: Metallic gray

F28 ▶무광백색 Flat white

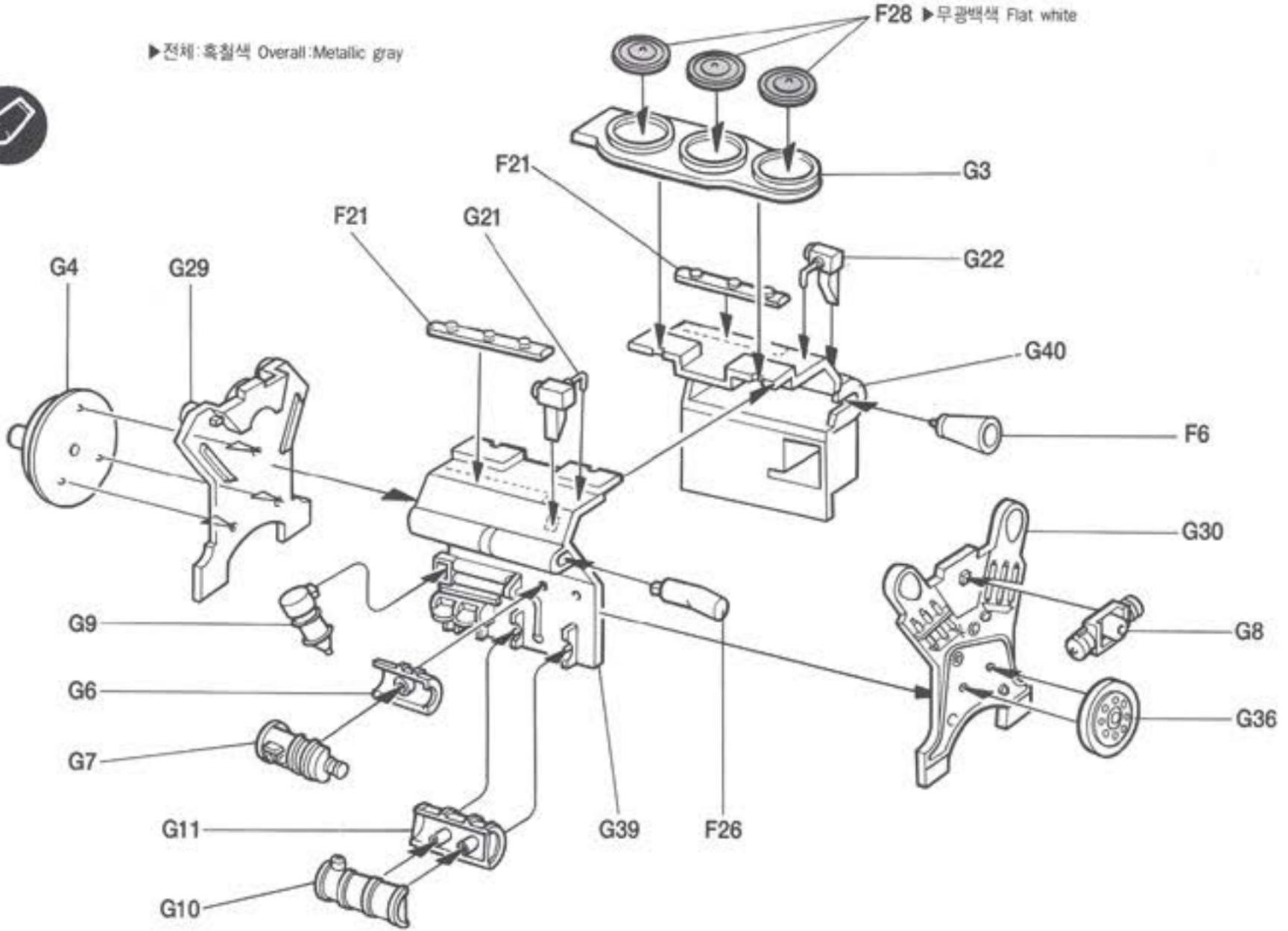

8

■ 올바게트리베 트랜스미션(Olva-getribe transmission)

▶전체: 흑철색 Overall: Metallic gray

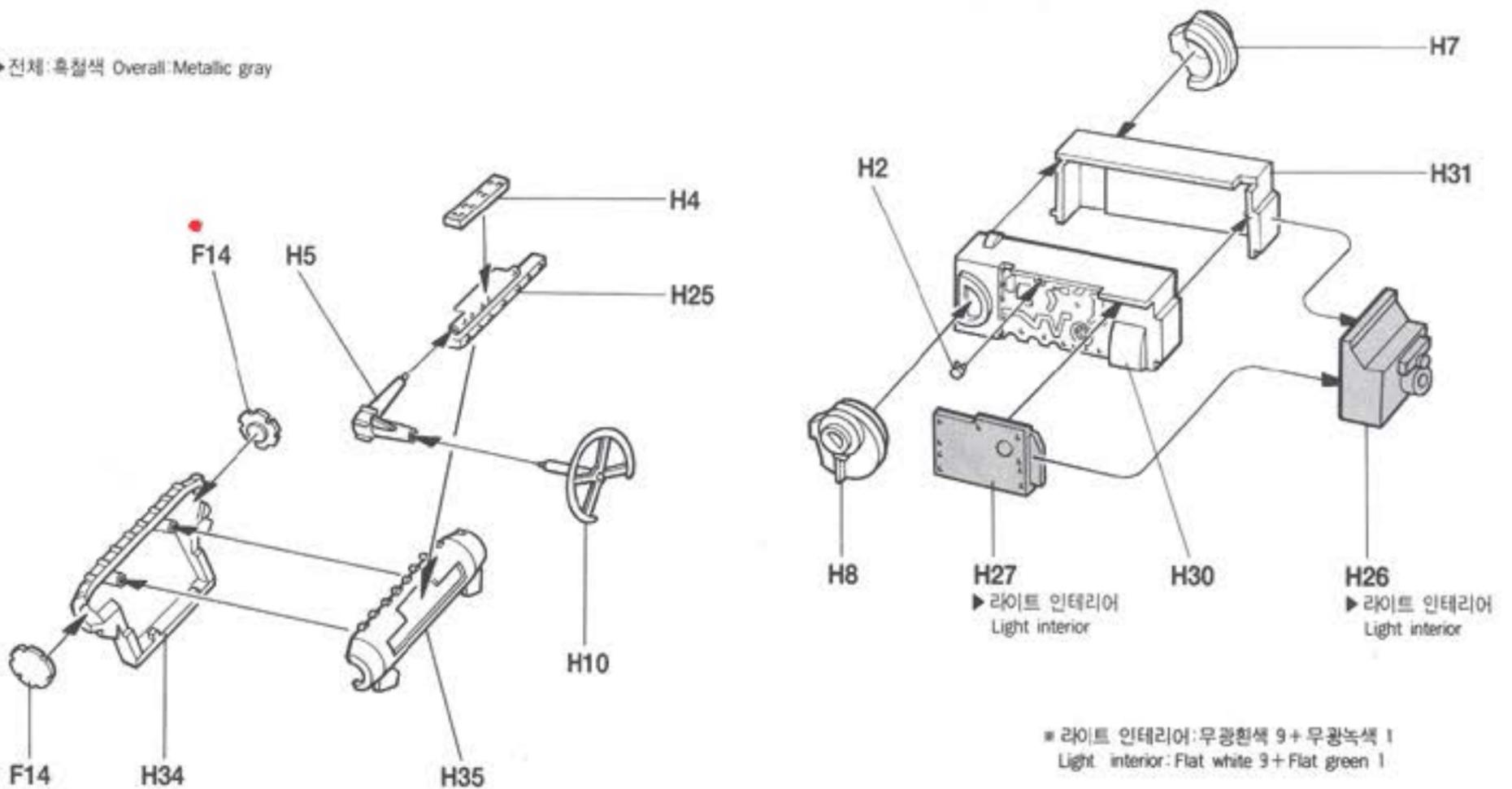

9

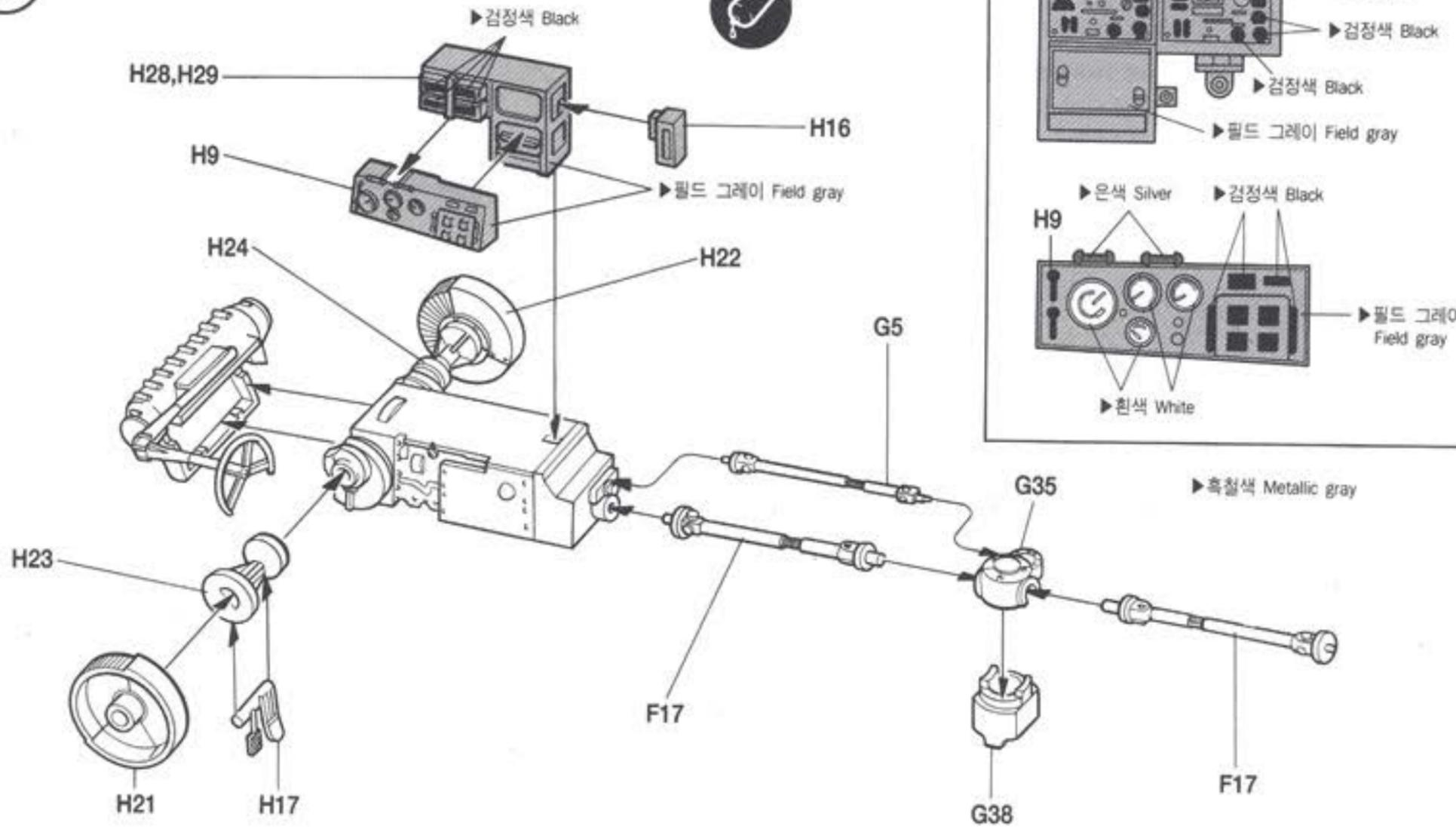

10

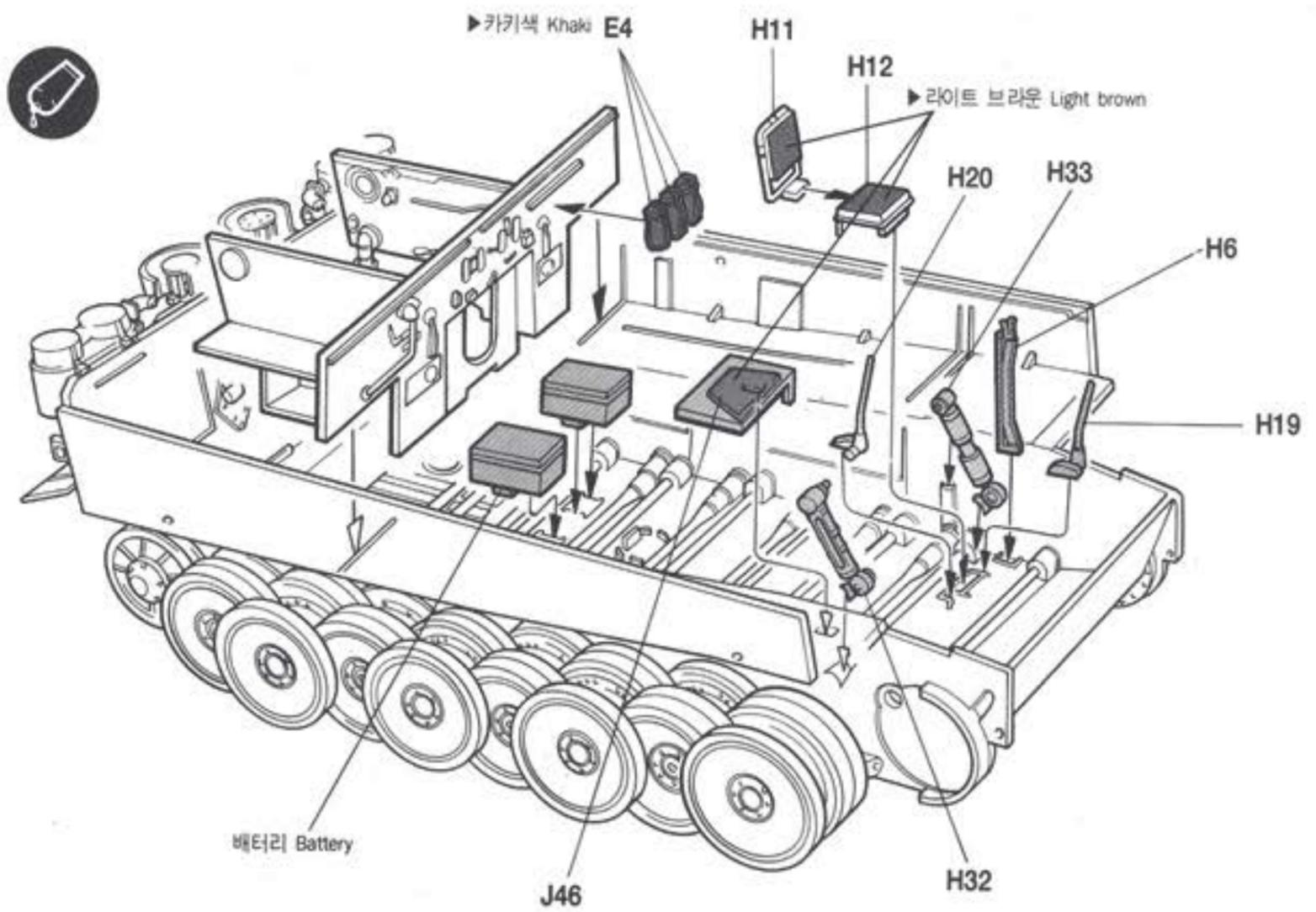
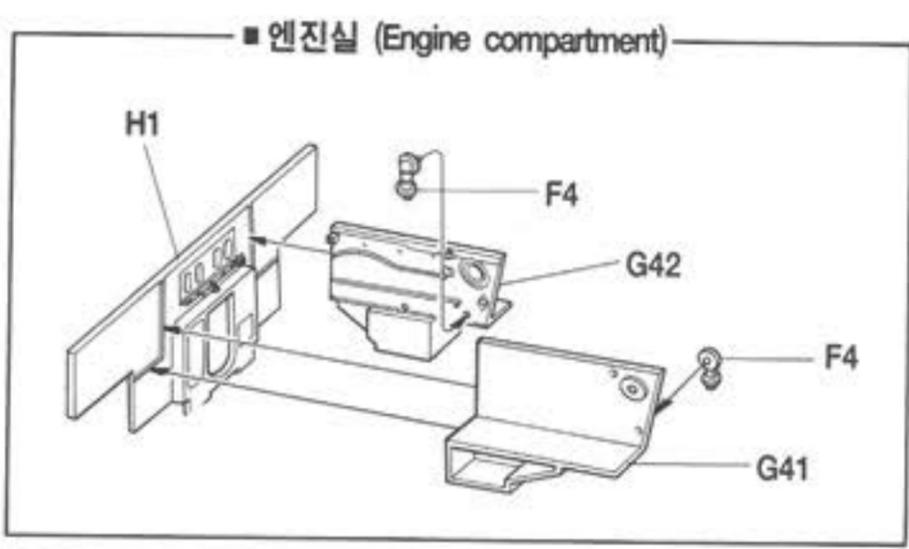
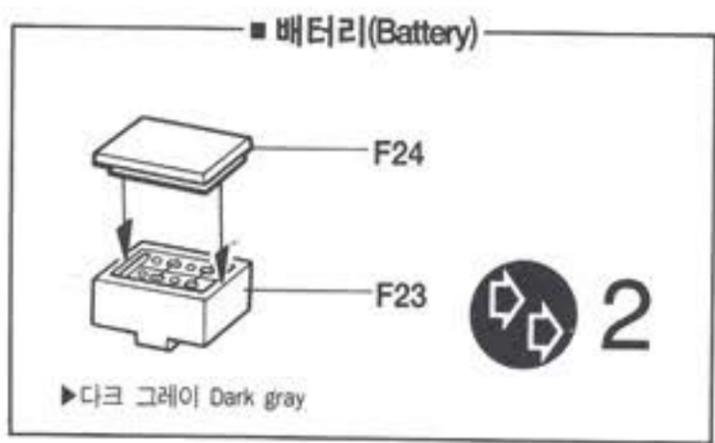

■ 탄약 적재함 A (Ammo stowage A)

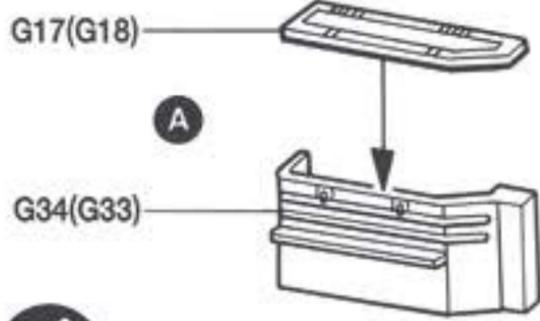

▶ 라이트 인테리어 Light interior

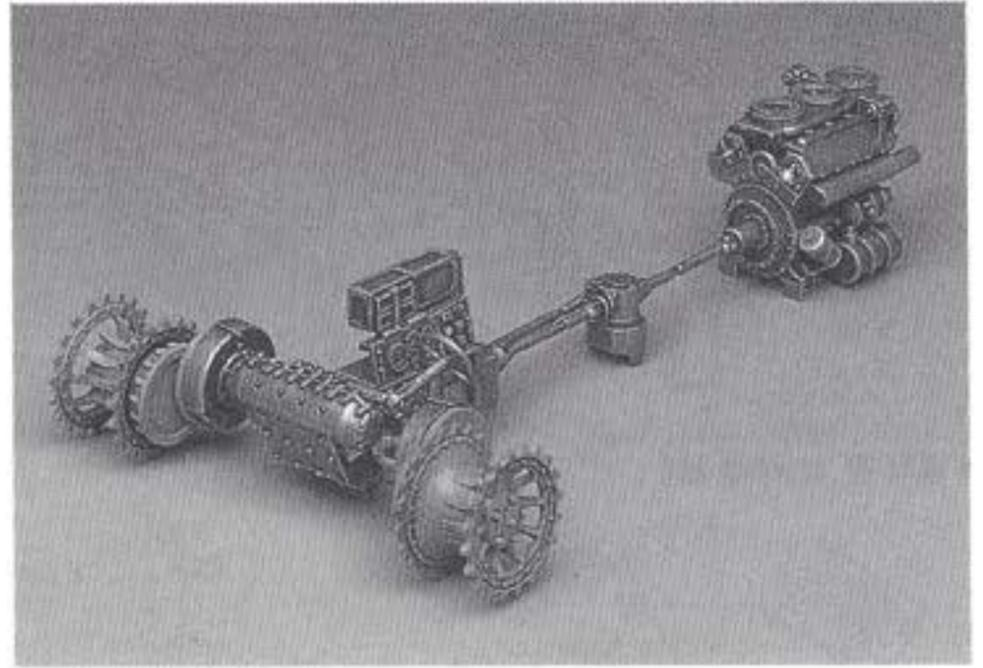
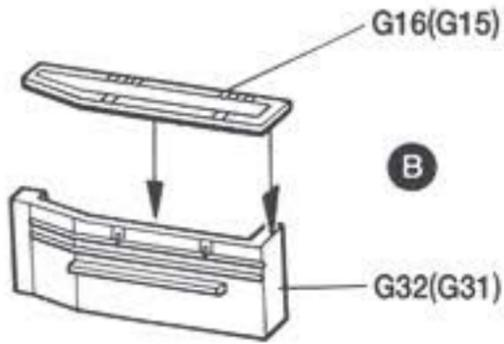

▶ 라이트 인테리어 Light interior

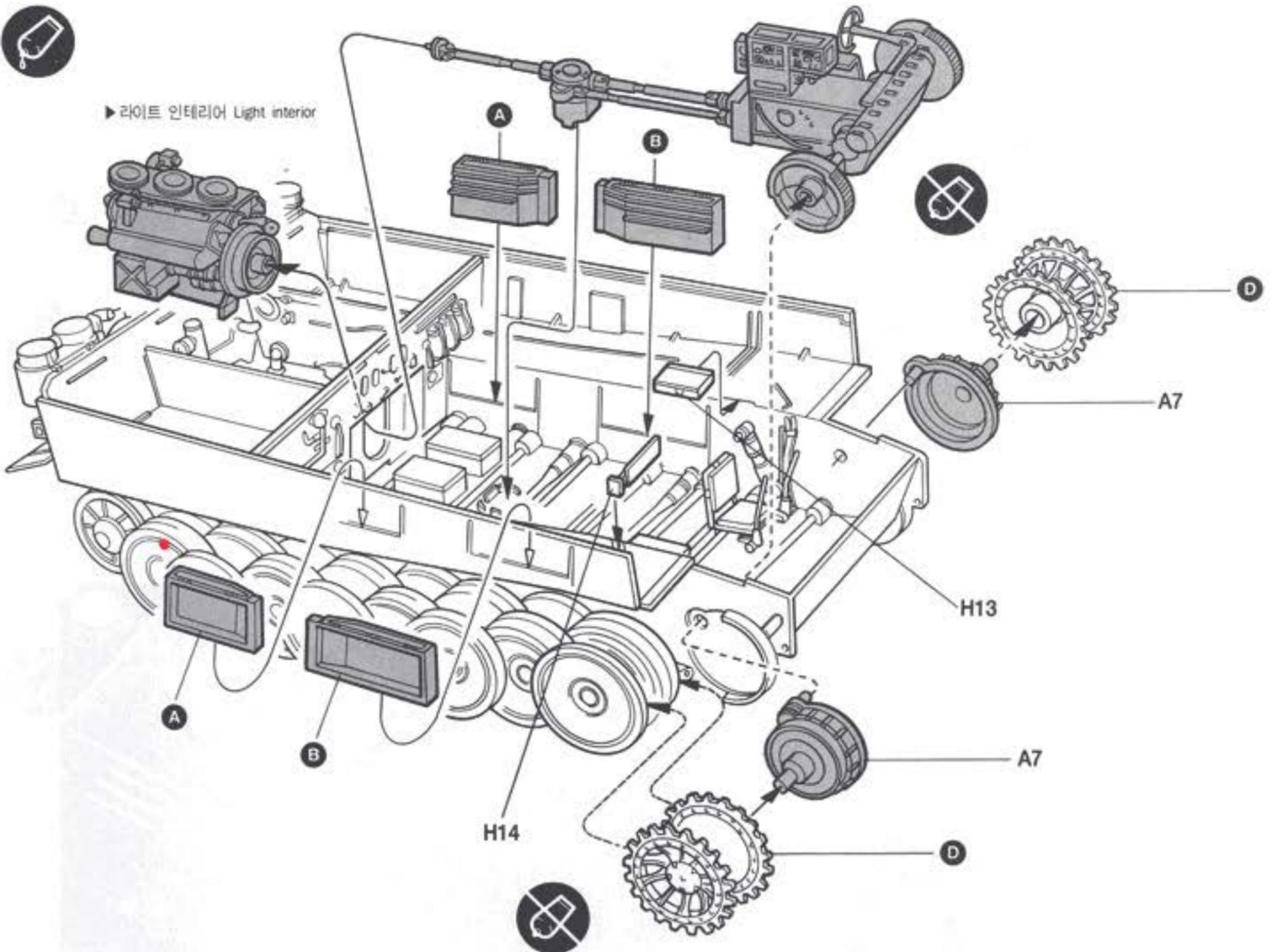

■ 라디에이터 (Radiator)

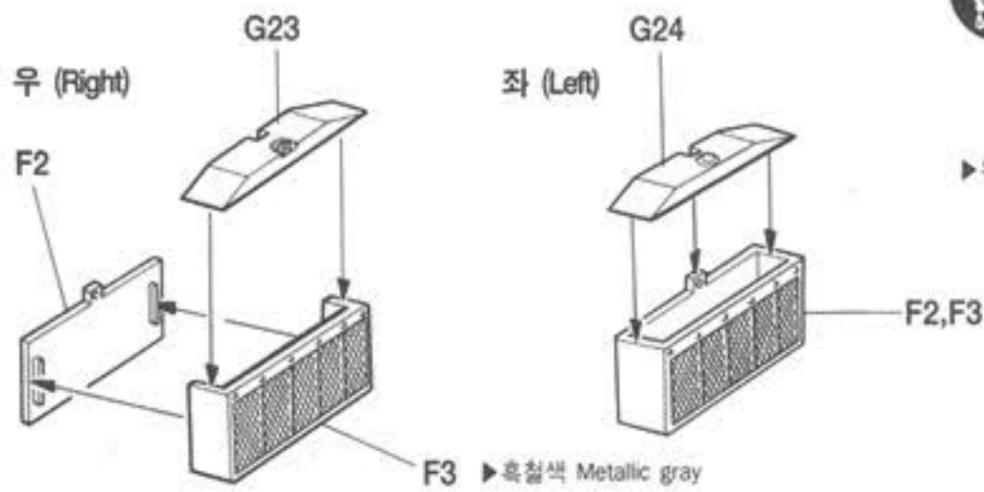

■ 탄약 적재함 B (Ammo storage B)

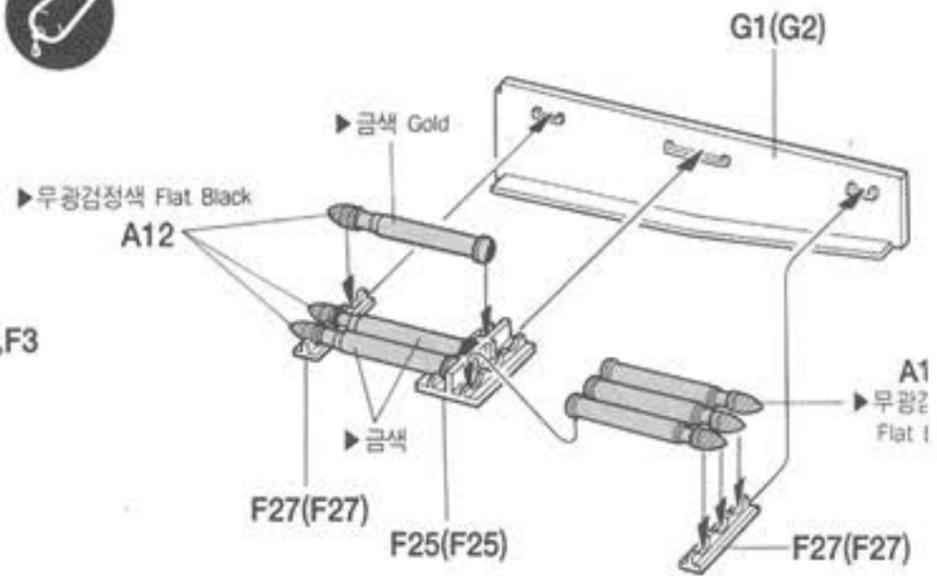

■ 냉각 팬 (Cooling fan)

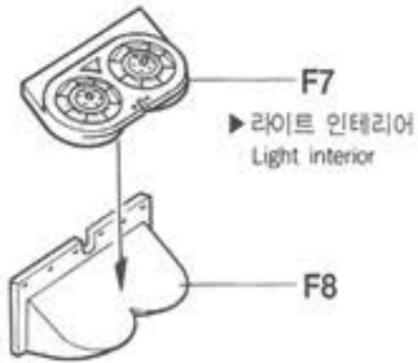

2

▶ 무광빨강색 Flat red G25

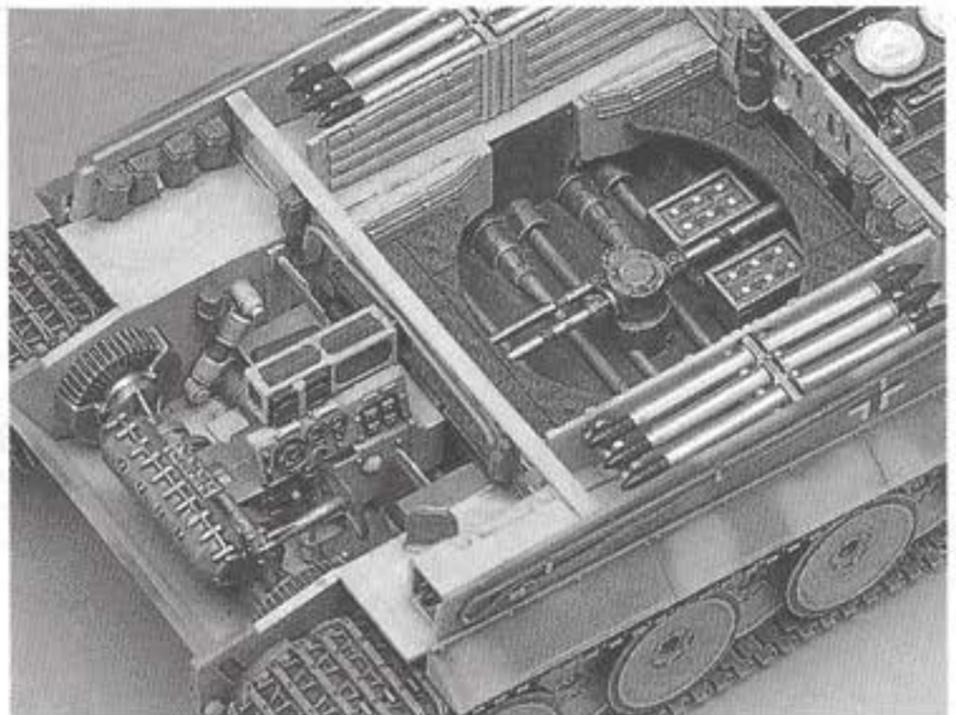
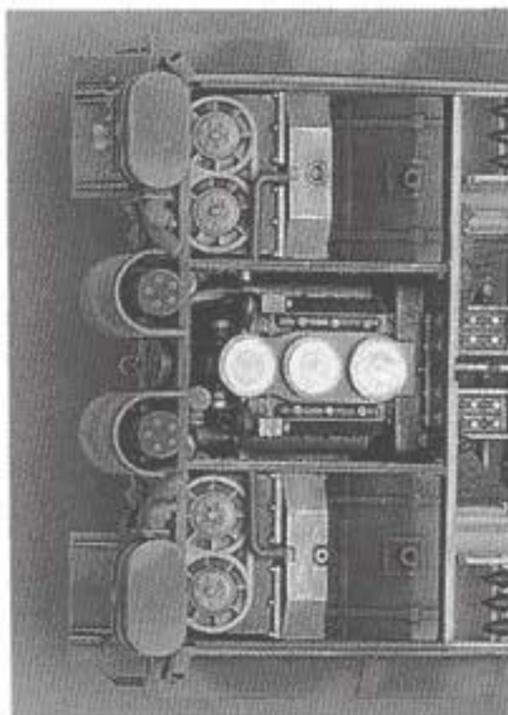
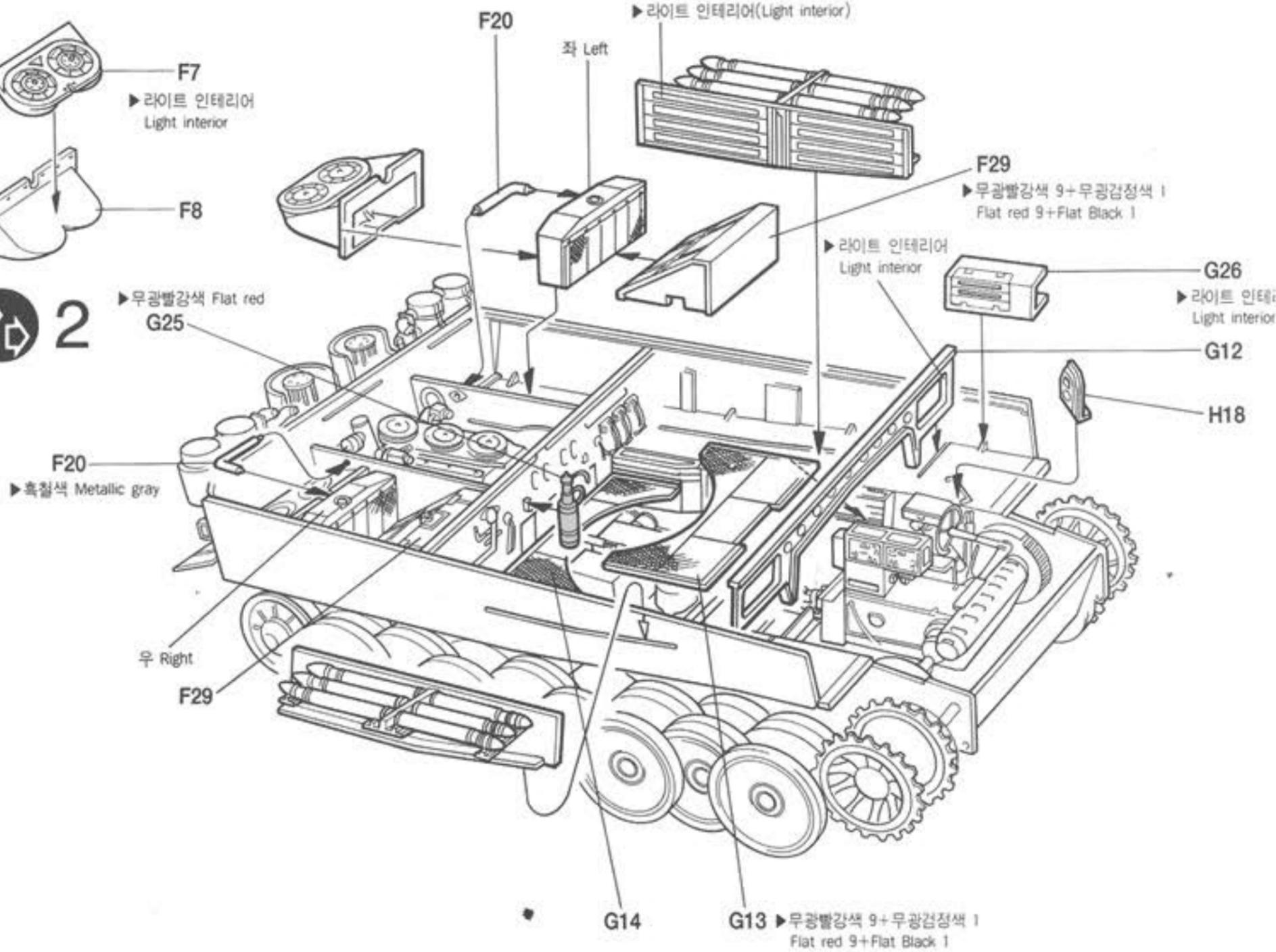

13

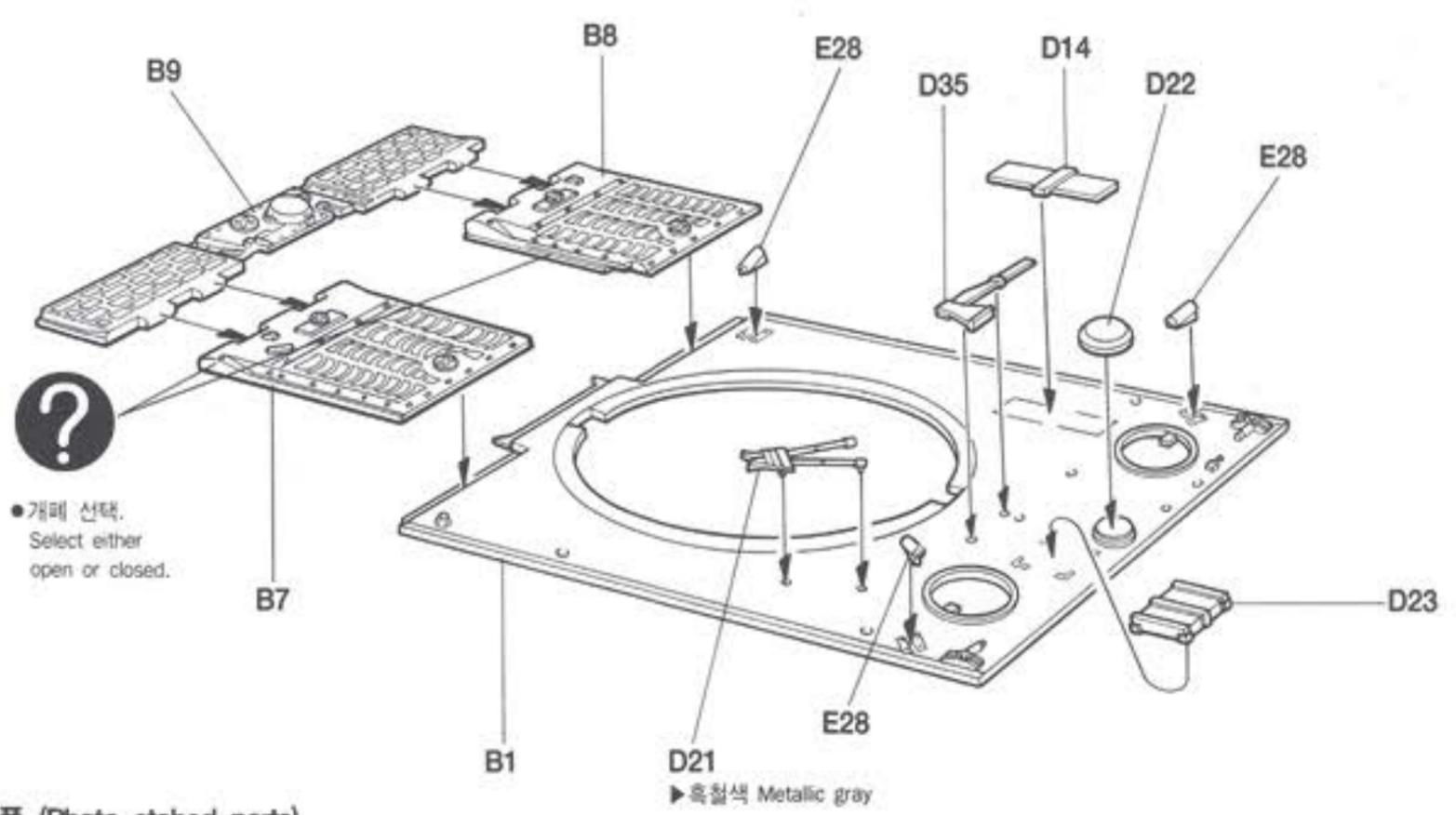

■ 에칭 부품 (Photo etched parts)

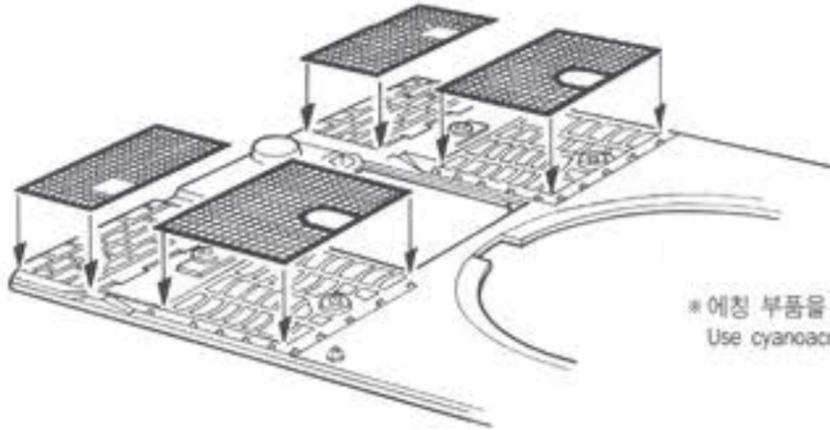

* 에칭 부품을 접착할때는 순간 접착제(발매)를 사용하십시오.
Use cyanoacrylate glue when attached photo etched parts.

14

■ 전면 헛치 (Front hatch)

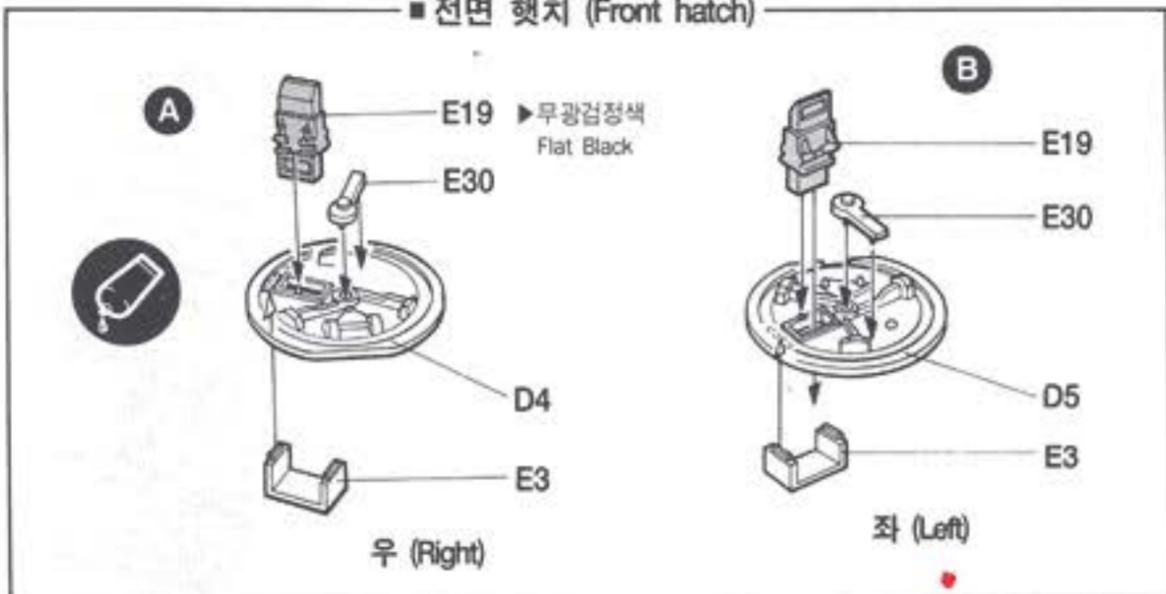

■ 열린 상태 (Open position)

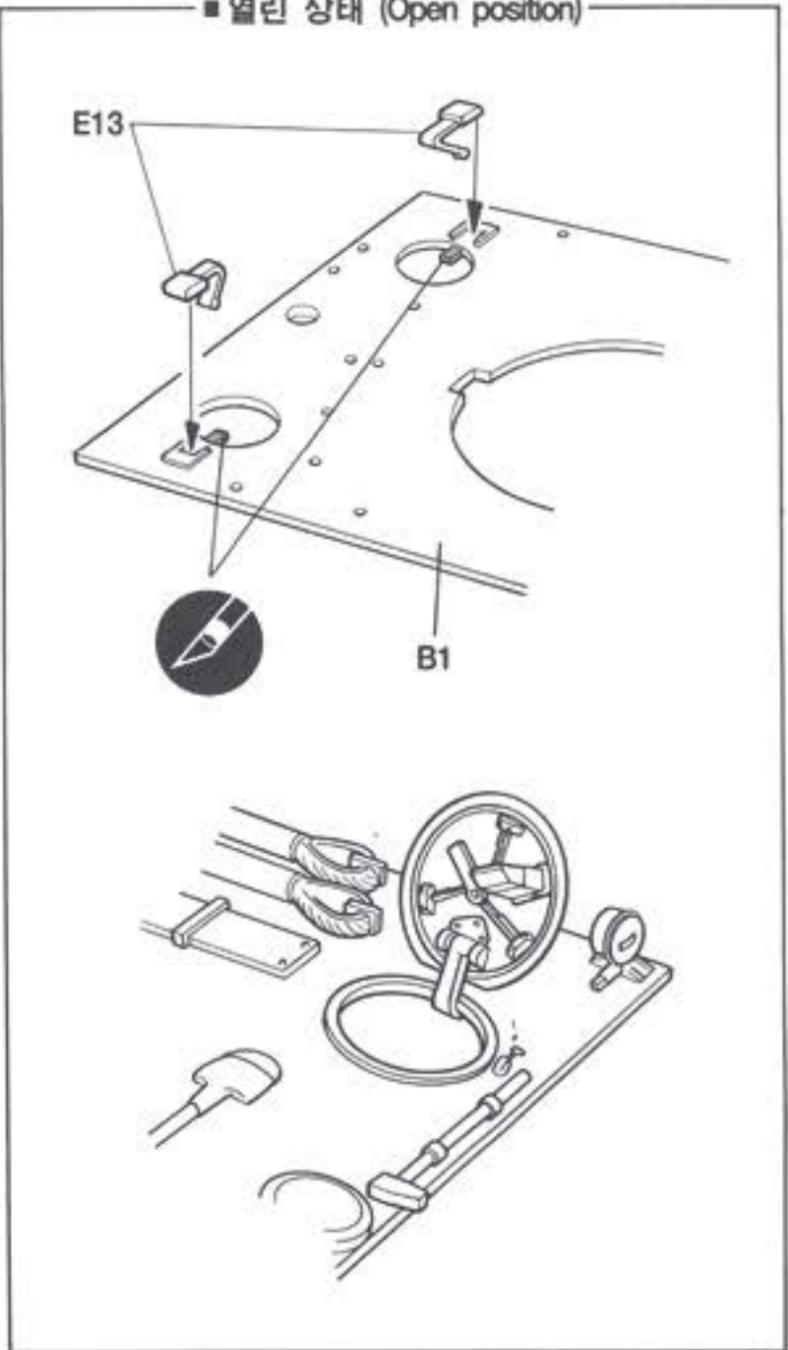

■ 엔진 헛치 (Engine access hatch)

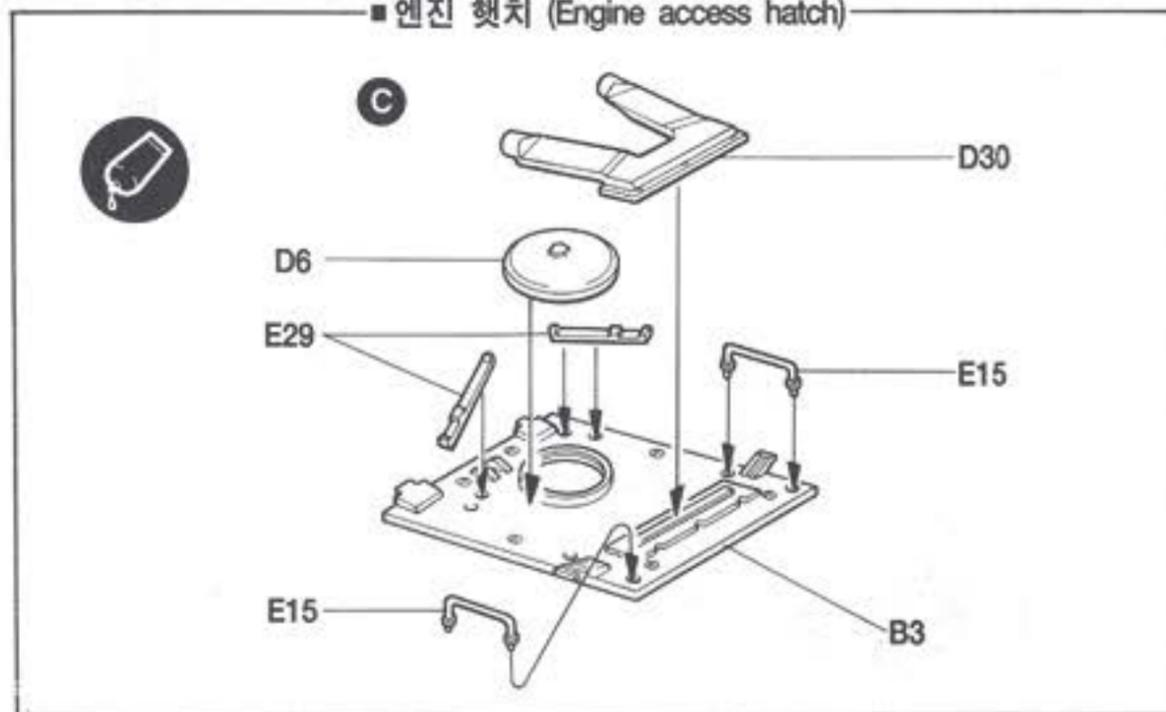

타이거 - I 초기형 내부 구조도

TIGER-I CUTAWAY VIEW DRAWING

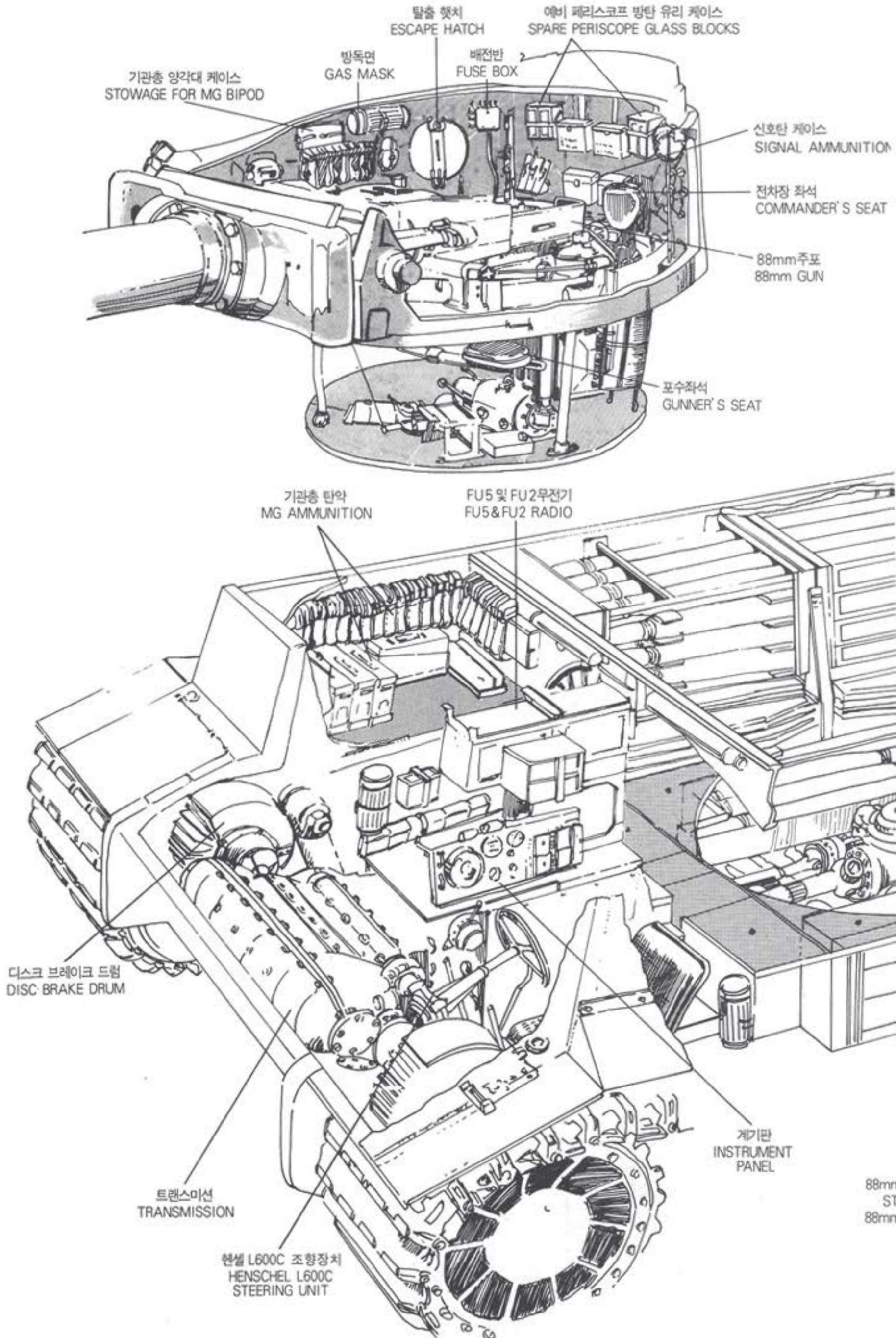

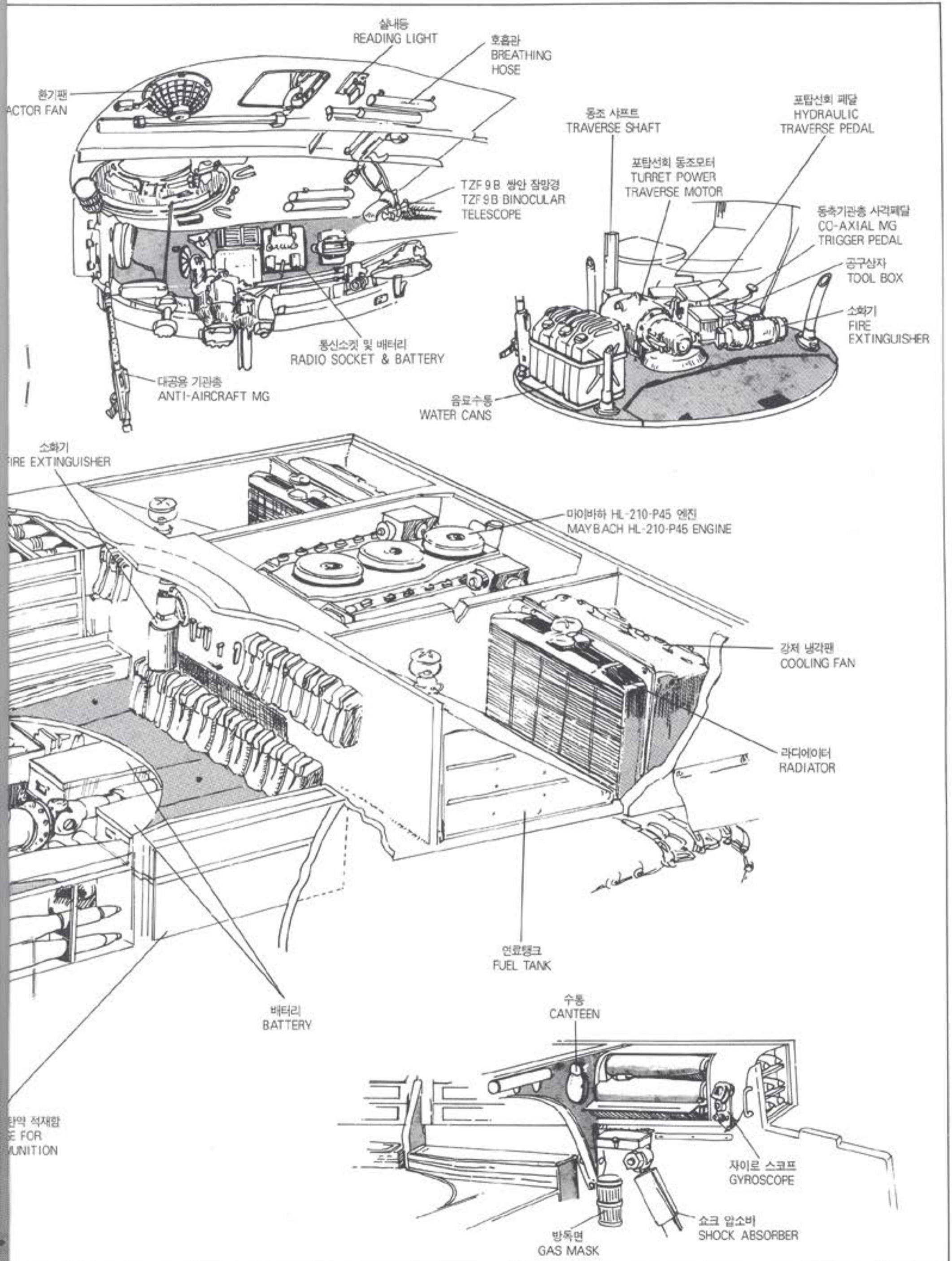

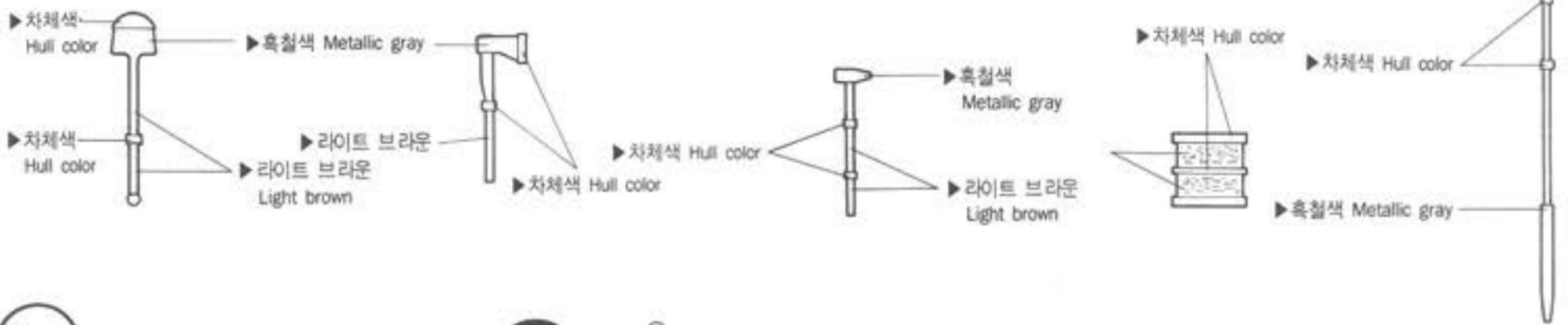

15

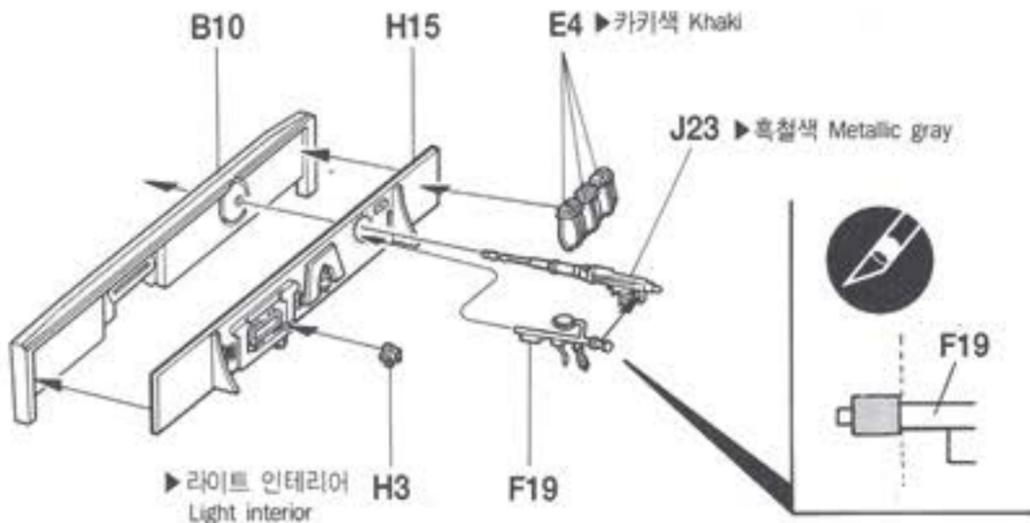
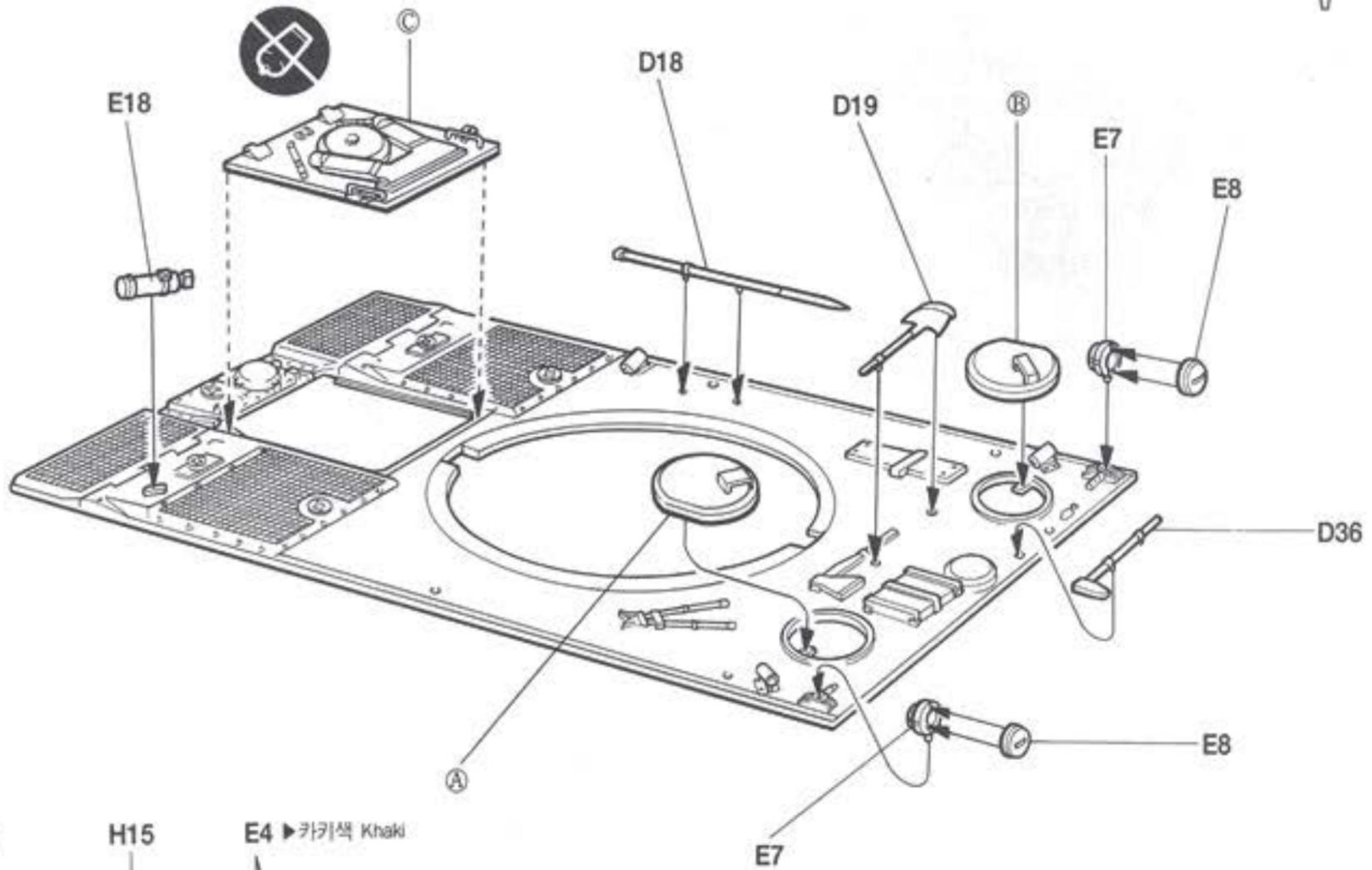

16

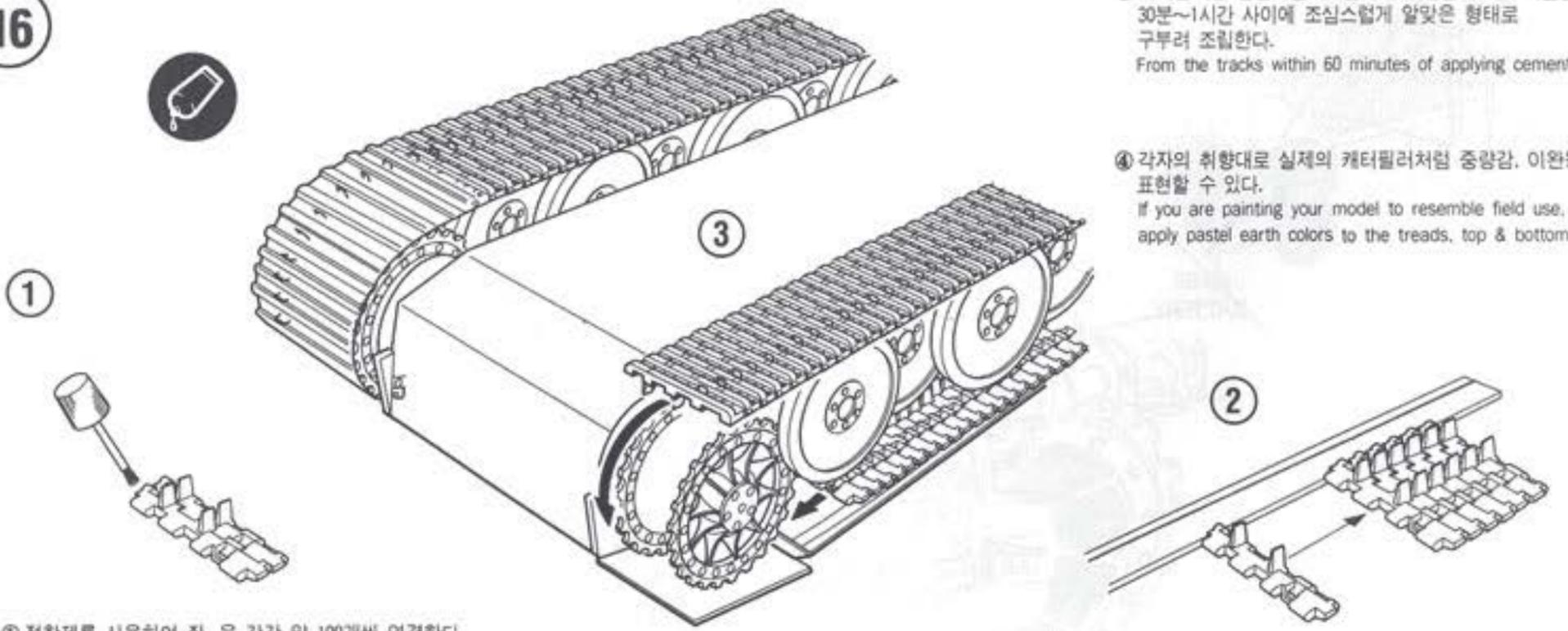

① 접착제를 사용하여 좌, 우 각각 약 100개씩 연결한다.
Use cement sparingly. Use a normal or slow-drying cement to assemble the tread blocks.

③ 캐터필러를 연결시킨 후 접착제가 완전히 마르기전인 30분~1시간 사이에 조심스럽게 알맞은 형태로 구부려 조립한다.
From the tracks within 60 minutes of applying cement.

④ 각자의 취향대로 실제의 캐터필러처럼 중량감, 이완등을 표현할 수 있다.
If you are painting your model to resemble field use, apply pastel earth colors to the treads, top & bottom.

② 자동을 이용하여 비뚤어지지않게 연결한다.
Assemble the tread blocks against a straight edge as shown.

17

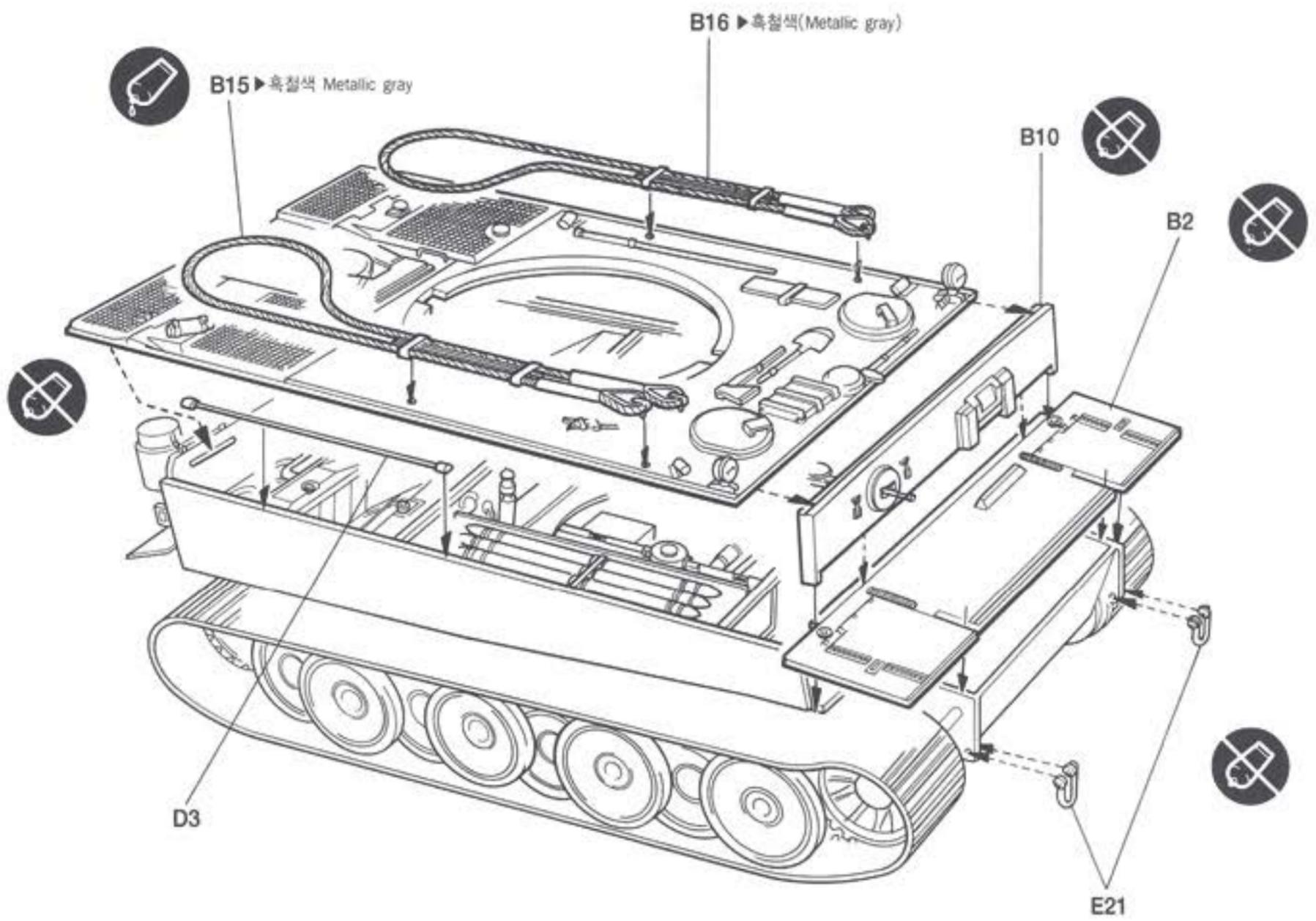

18

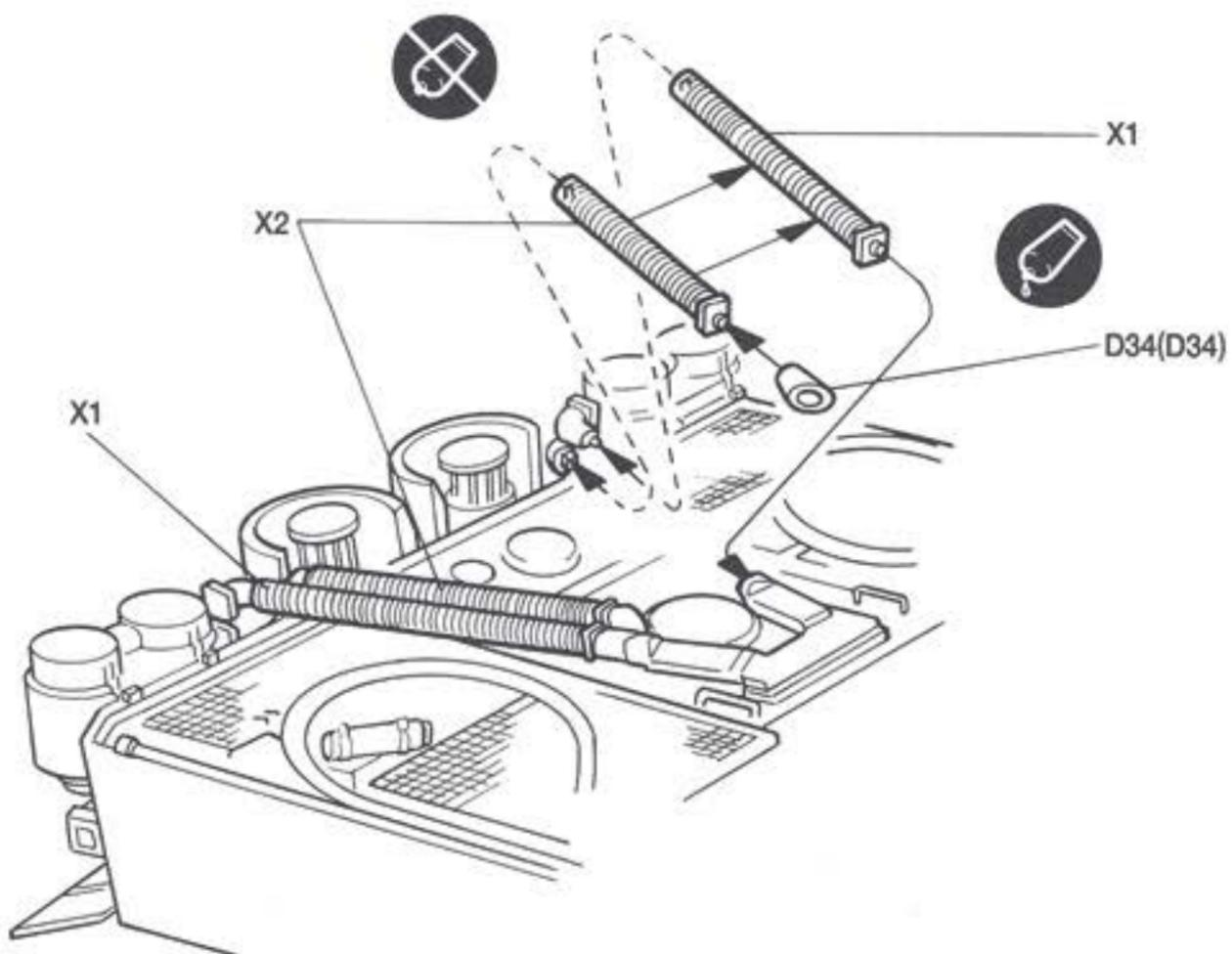

* 접착할때에는 순간 접착제를 사용한다.
Use cyanoacrylate glue.

19

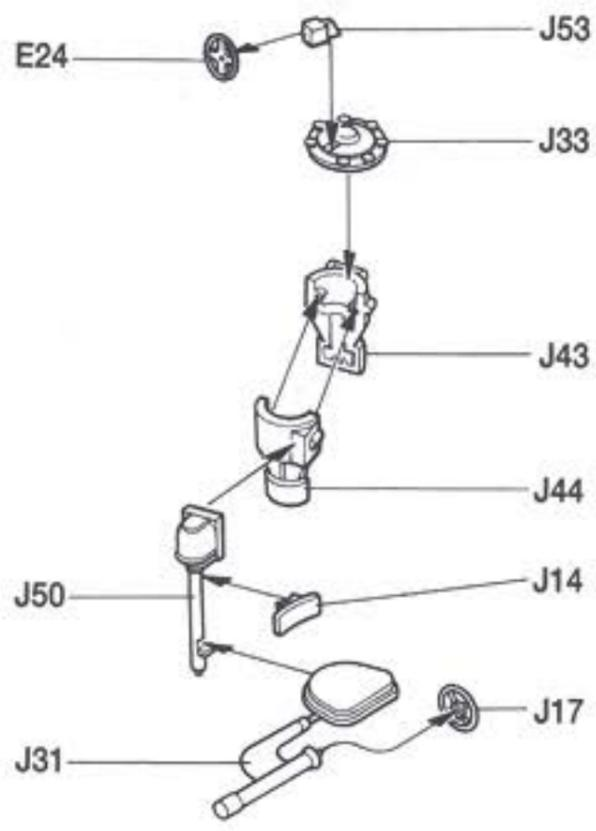

▶ 내부 전체색: 라이트 인테리어
Overall: Light interior

20

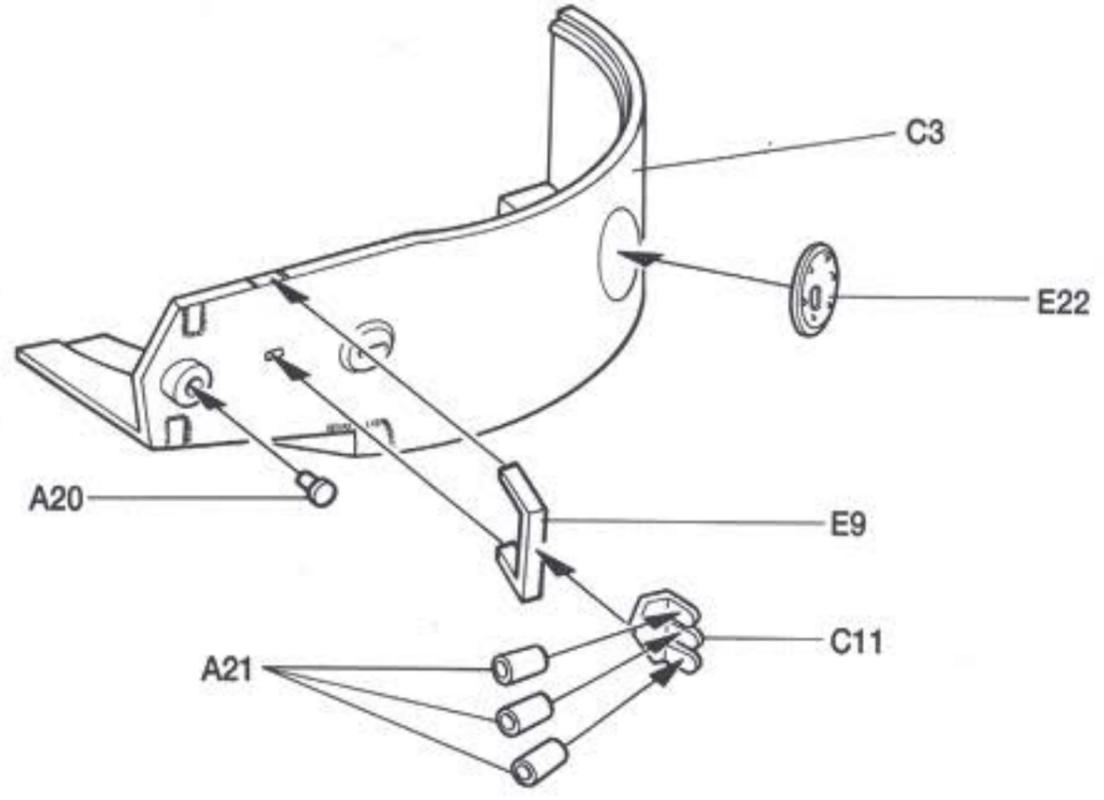
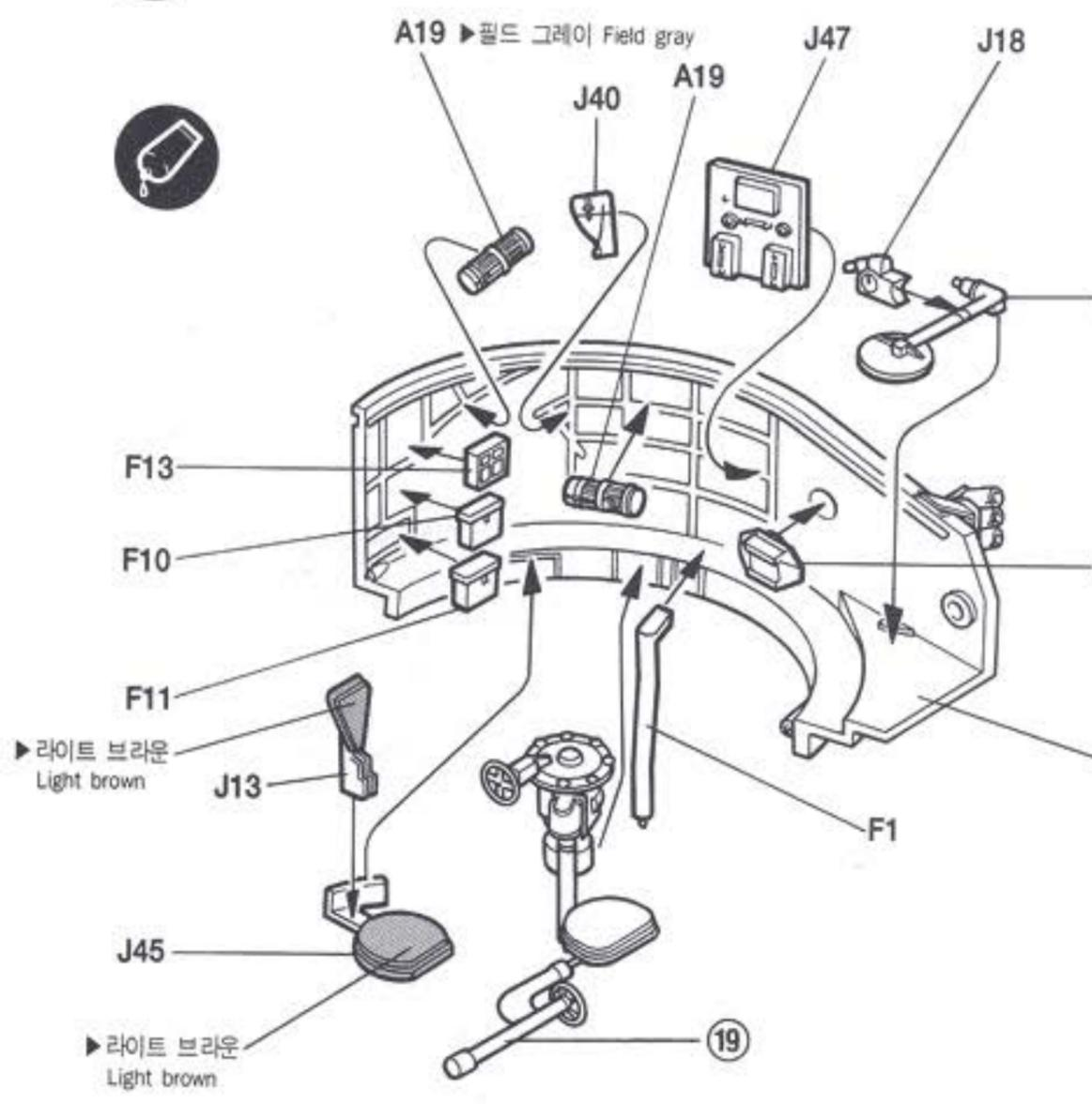

좌 (Left)

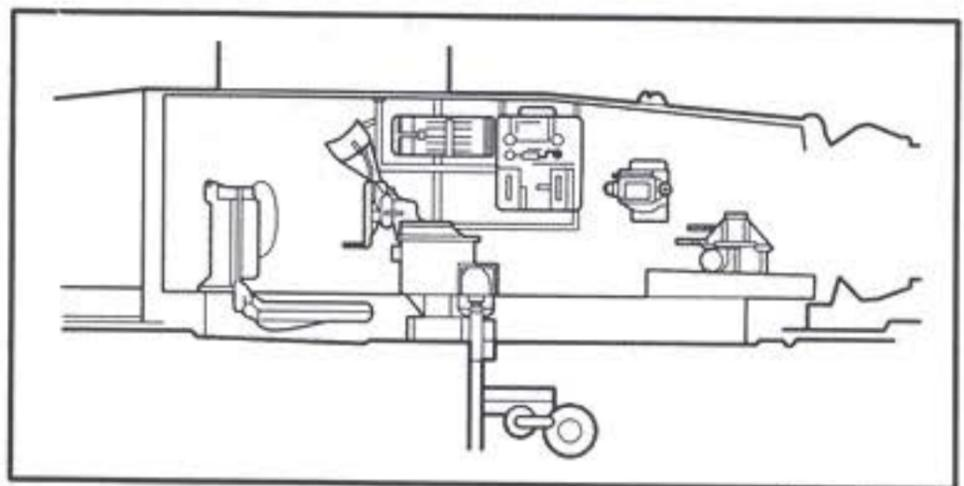

21

▶내부 전체색: 라이트 인테리어
Overall: Light interior

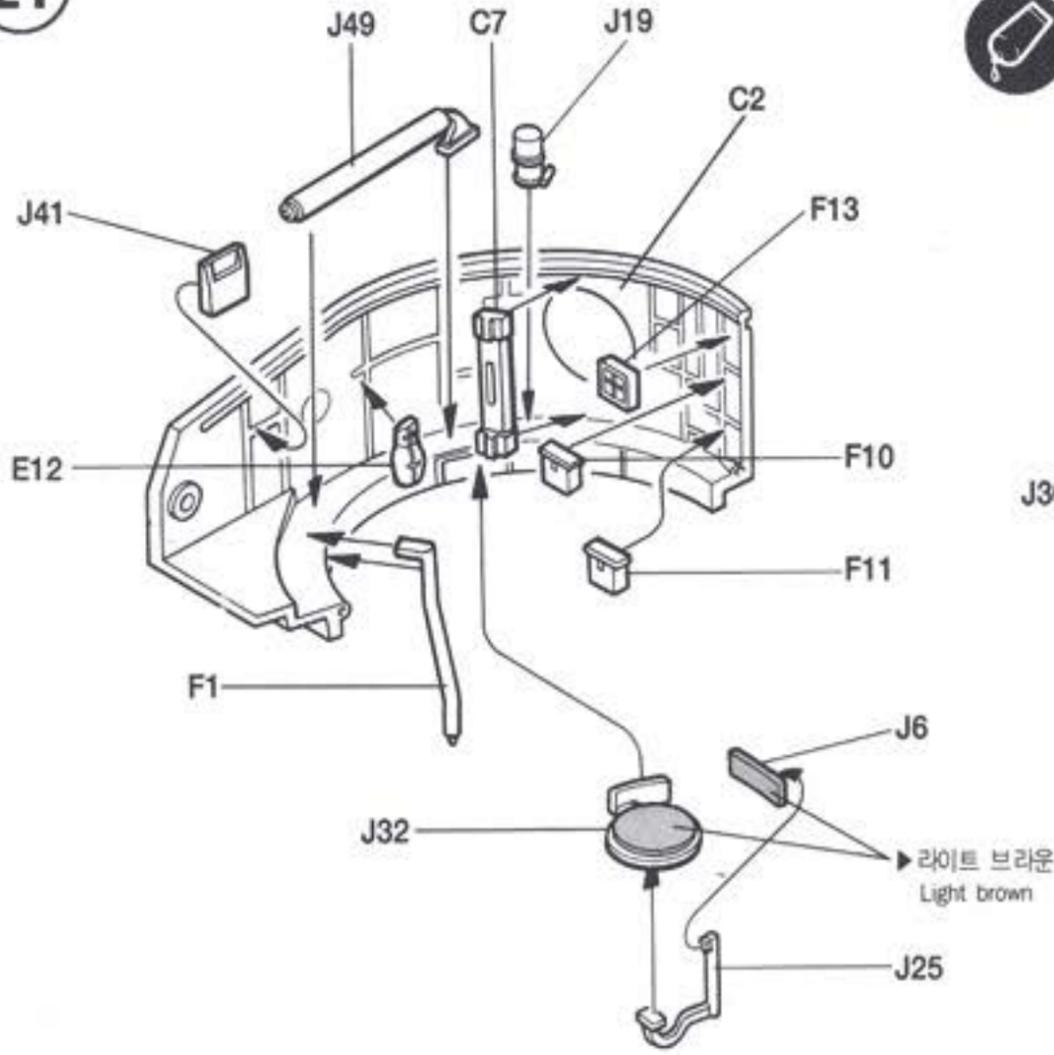

우 (Right)

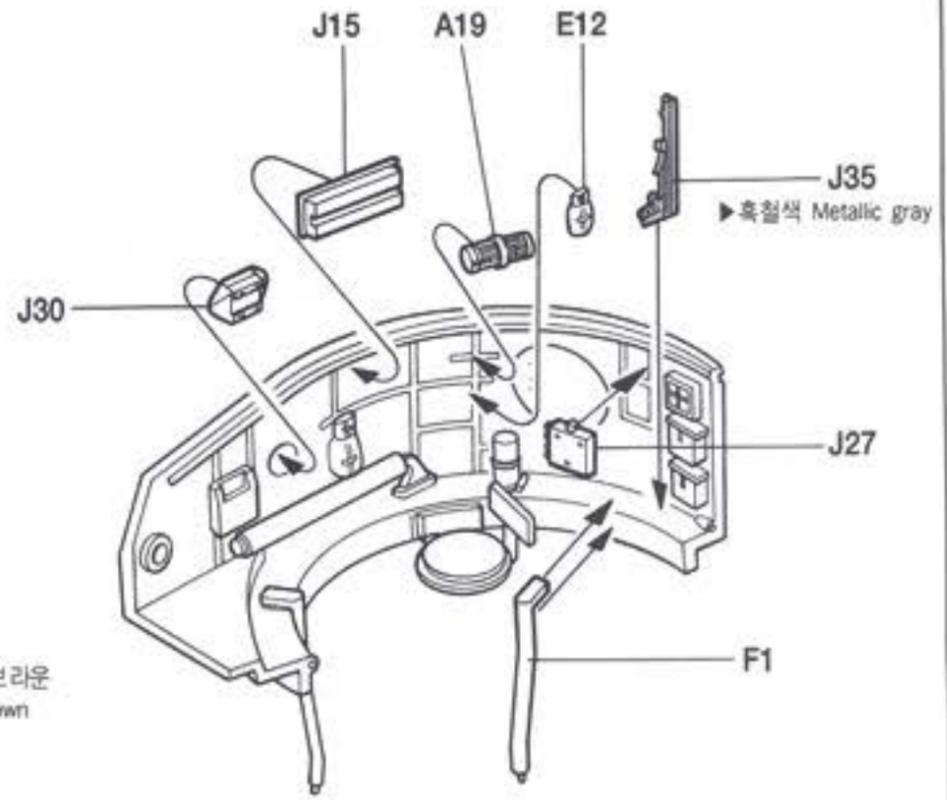

후부 (Rear)

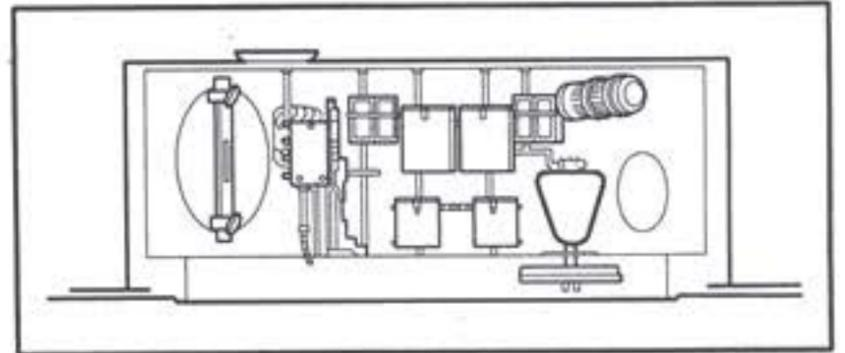
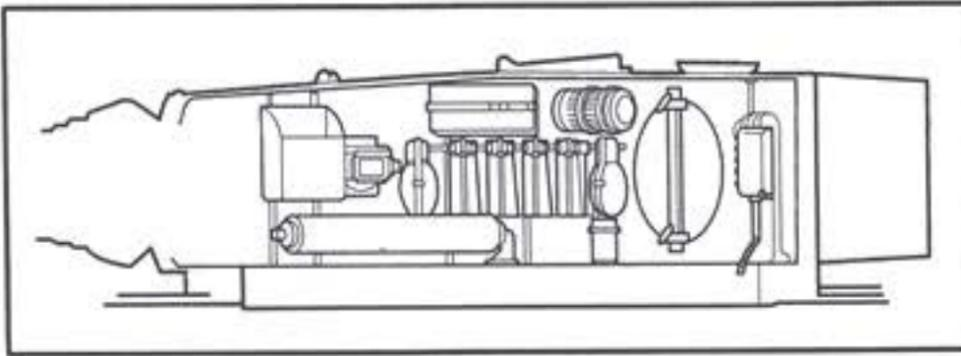

22

A 동축 기관총 페달 (Co-axial MG trigger pedal)

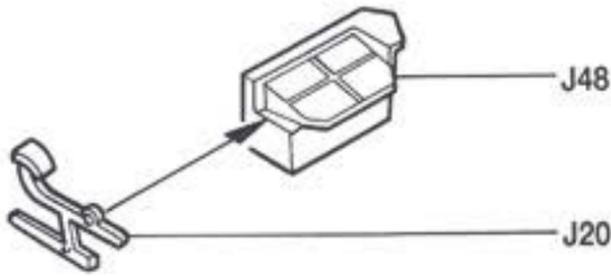

B 유압 동조 모터 (Hydraulic traverse motor)

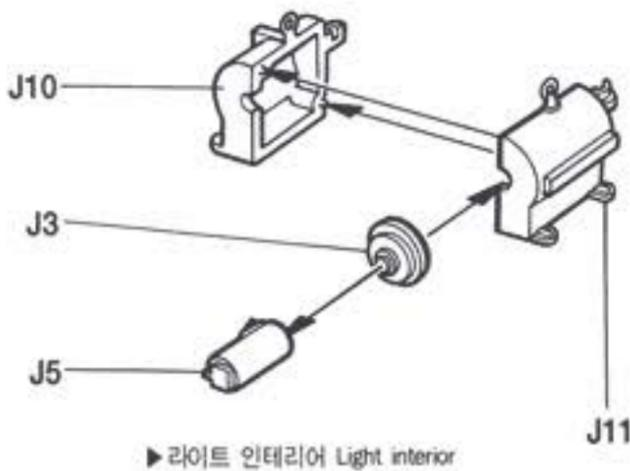

▶라이트 인테리어 Light interior



C 음료수통 (Water cans)

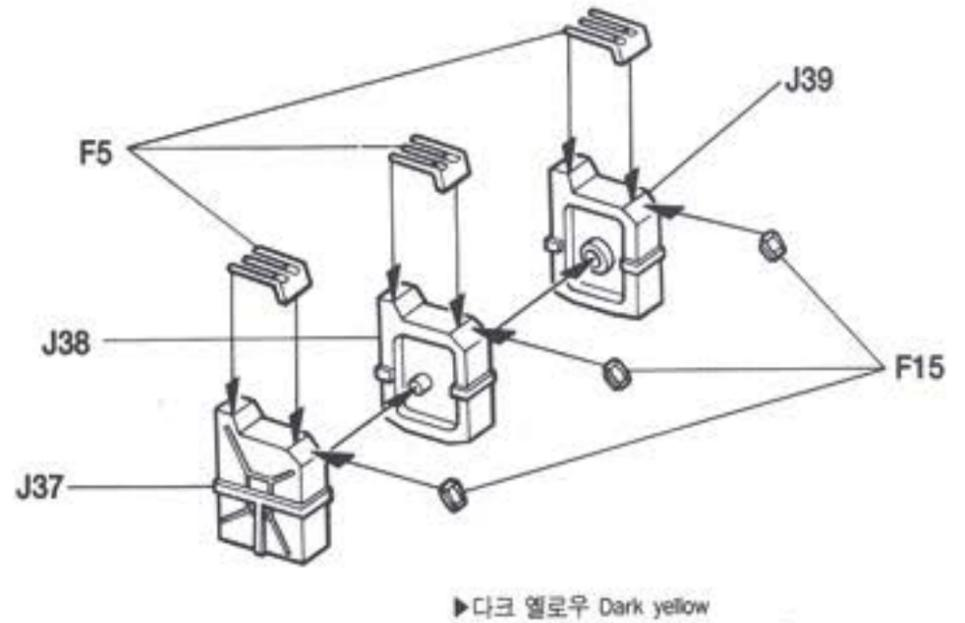

▶다크 옐로우 Dark yellow

23

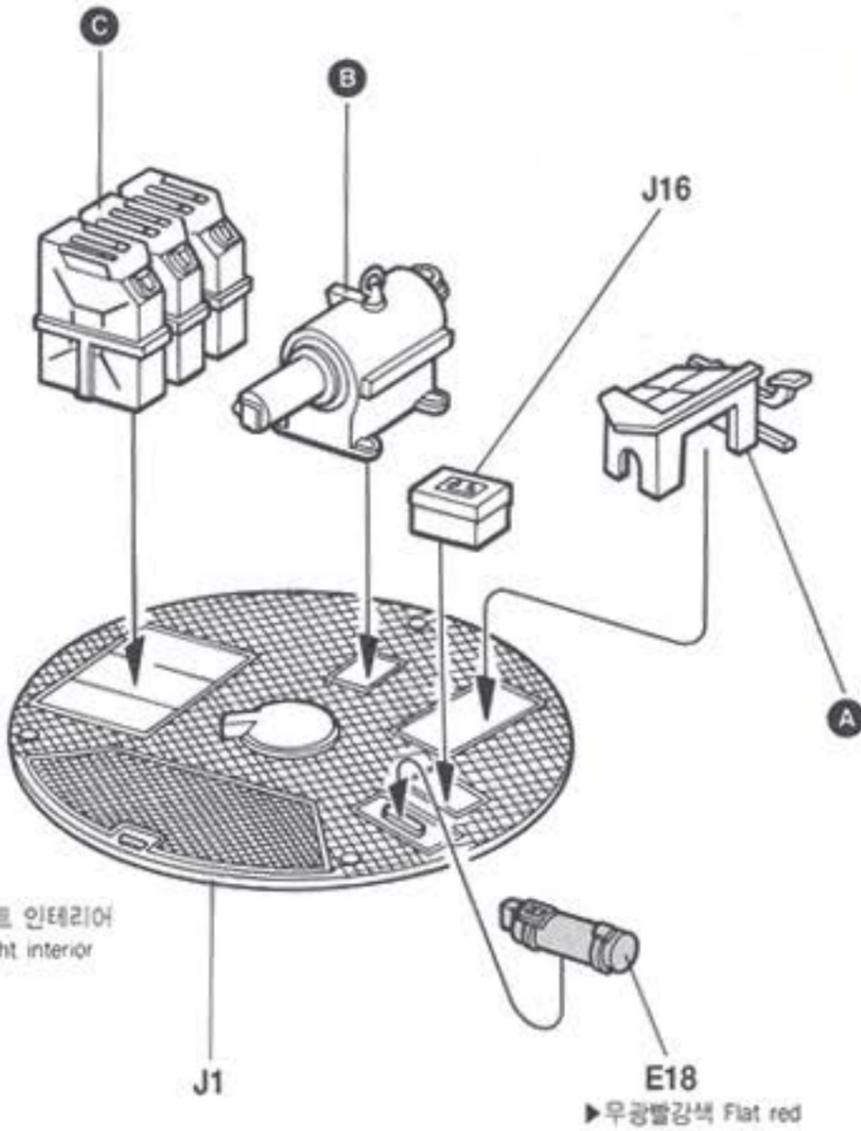

▶전체: 라이트 인테리어
Overall: Light interior

▶무광빨강색 Flat red

■ 바닥판 (Deck plate)

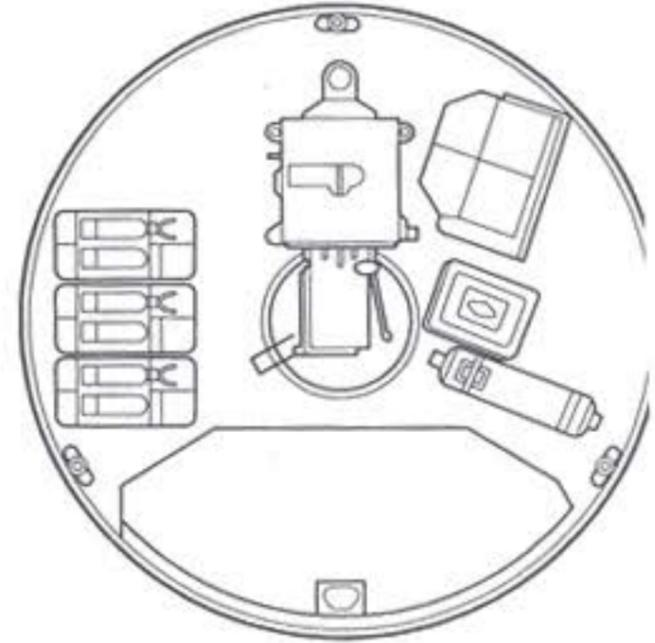

24

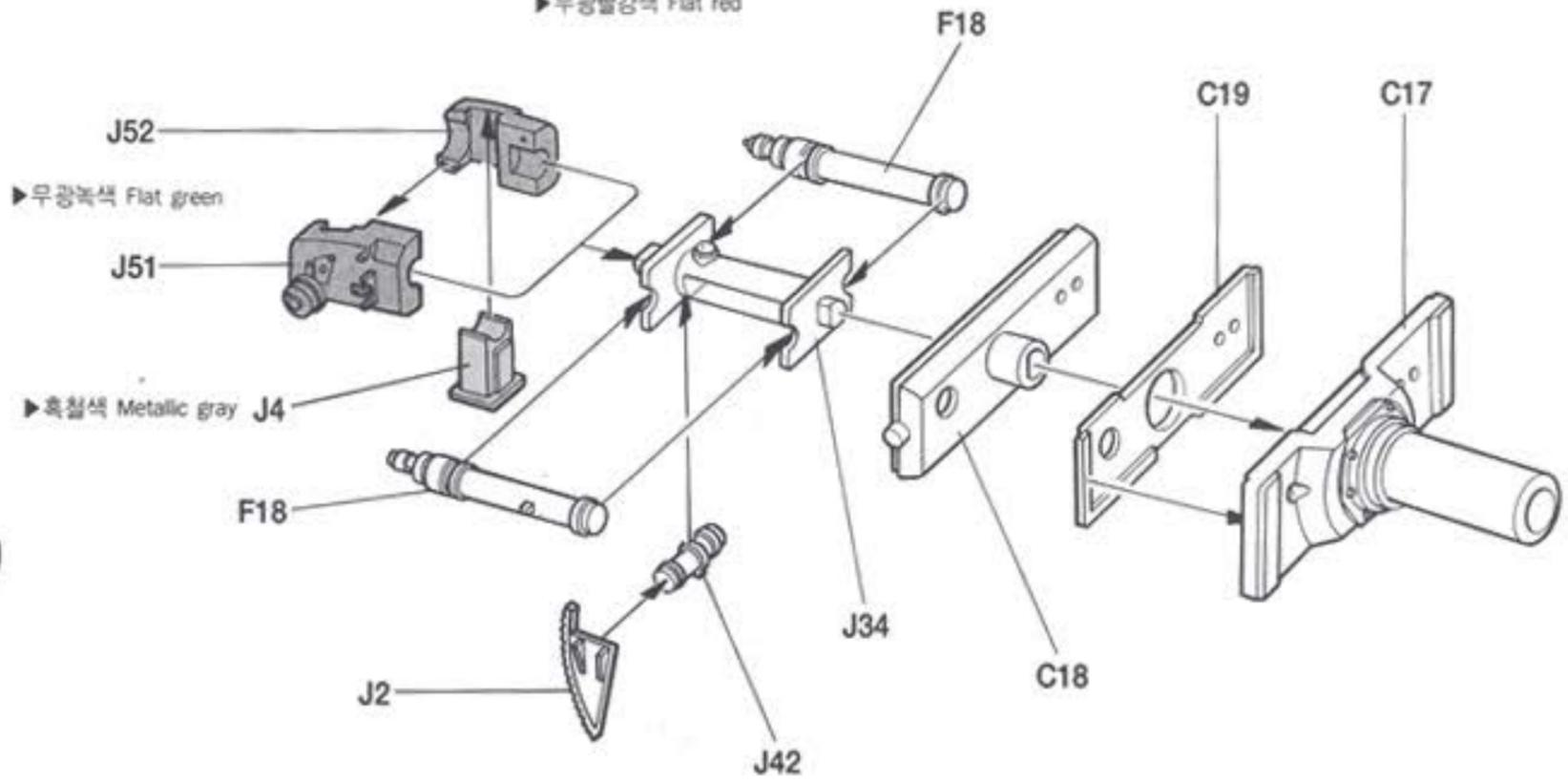

▶무광녹색 Flat green

▶흑철색 Metallic gray

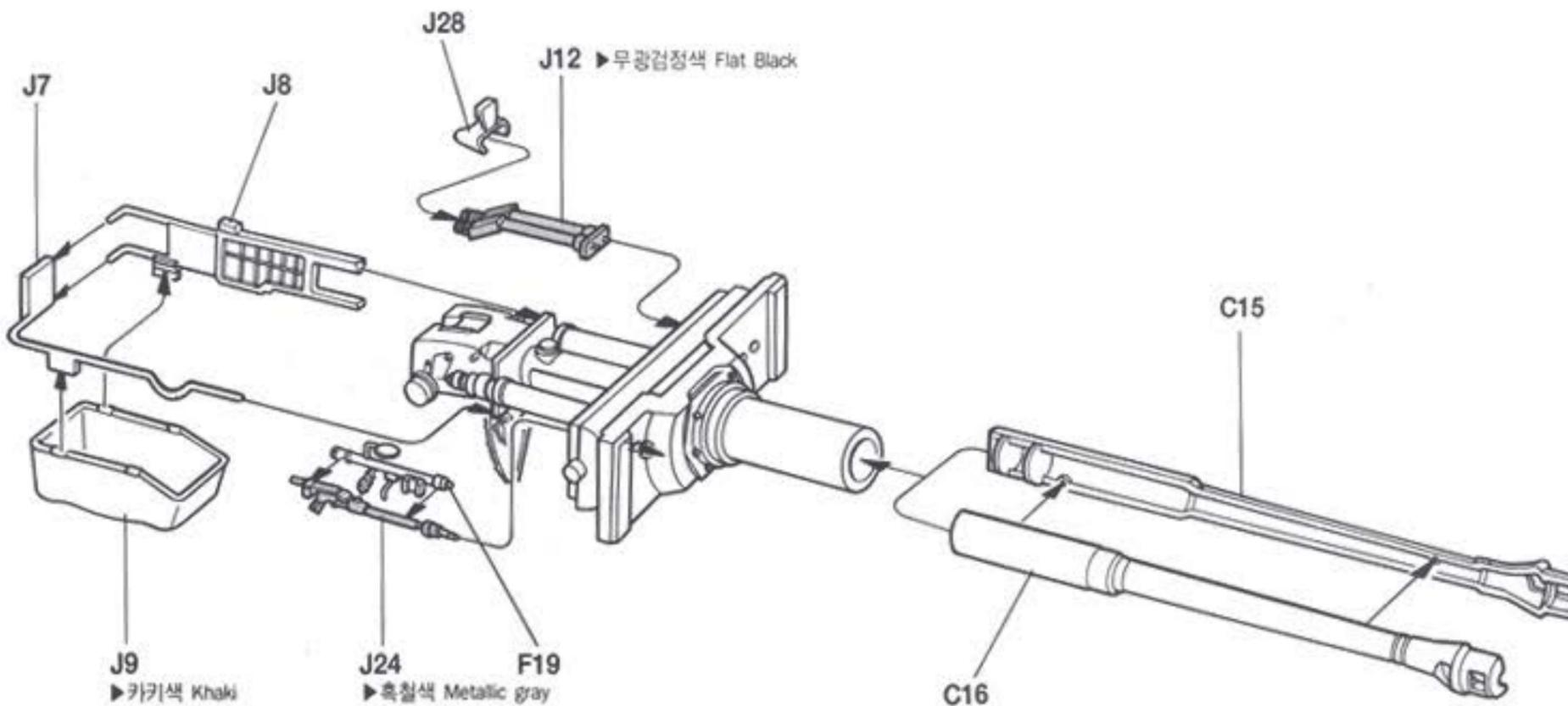

▶카키색 Khaki

▶흑철색 Metallic gray

25

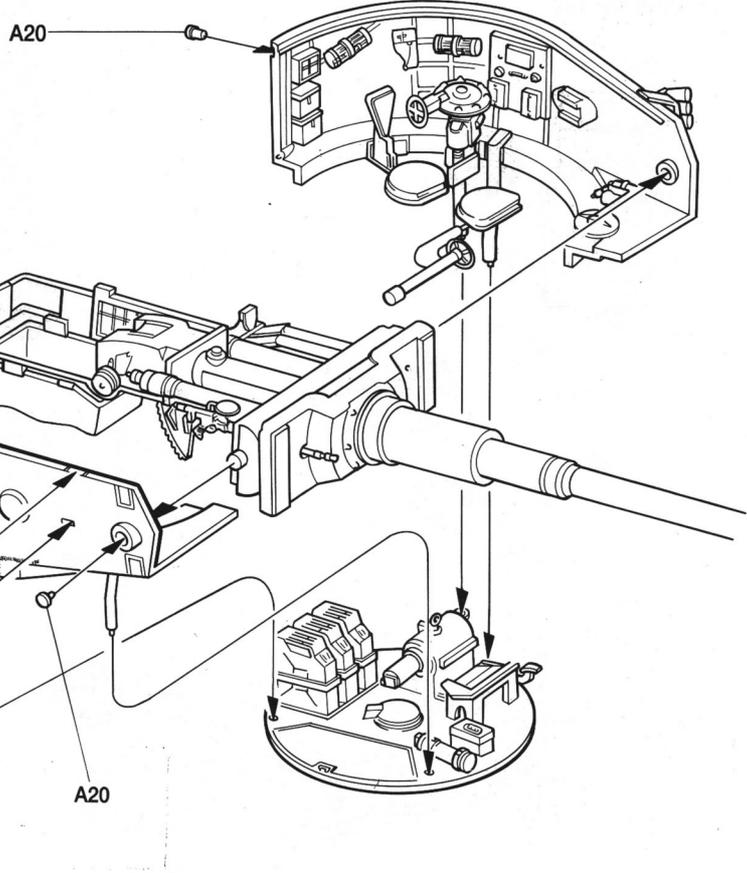

● 후기 사양만 조립한다.
Option for late type



26

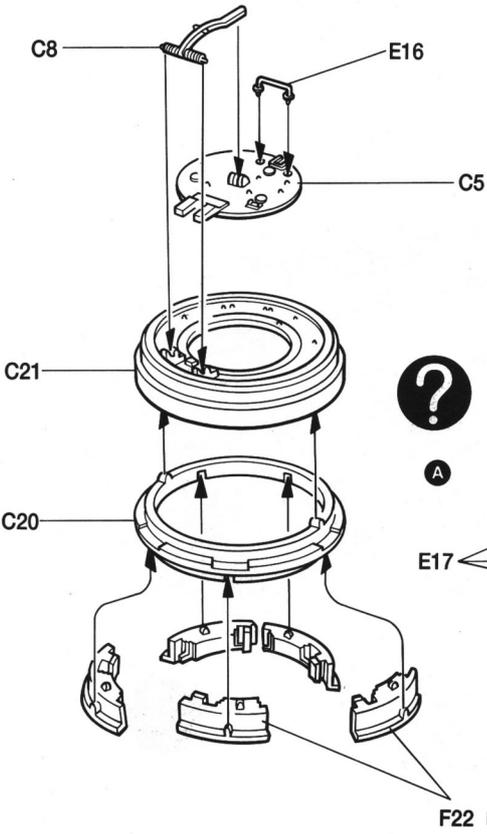
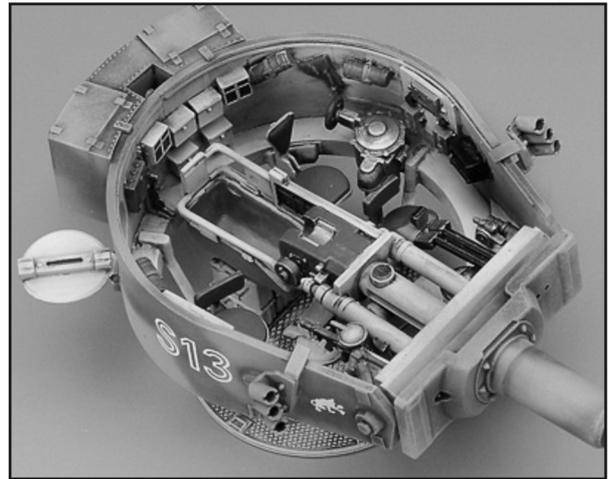

A

▶ 무광검정색 Flat Black

F22 ▶ 무광검정색 Flat Black

B

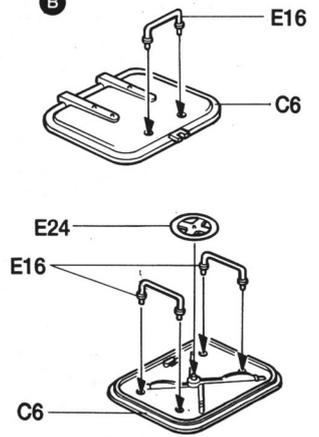

27 ■ 수납상자 (Stowage bin)

ENGLISH	FRENCH	GERMAN	SPANISH	ITALIAN
BLACK	NOIR	SCHWARZ	NEGRO	NERO
SILVER	ARGENT	SILBERN	PLATA	ARGENTO
GUNMETAL	METALLIC	METALLIC	METALICO	METALLICO
METALLIC	METALLIC	METALLIEK	METALICO	METALLICO
GRAY	GRIS	GRAU	GRIS	GRIGIO
LT GRAY	GRIS CLAIR	HELLGRAU	GRIS CLARO	GRIGIO CHIARO
RED	ROUGE	ROT	ROJO	ROSSO
YELLOW	JAUNE	GELB	AMARILLO	GIALLO
BLUE	BLEU	BLAU	AZUL	BLU
ORANGE	ORANGE	ORANGE	NARANJADO	ARANCIO
GREEN	VERT	GRUN	VERDE	VERDE
BROWN	BRUN	BRAUN	MARRON	MARRON
FLAT	TERNE	GLANZLOSES	APAGADO	OPACO
CLEAR	CLAIR	KLAR	CLARO	CHIARO

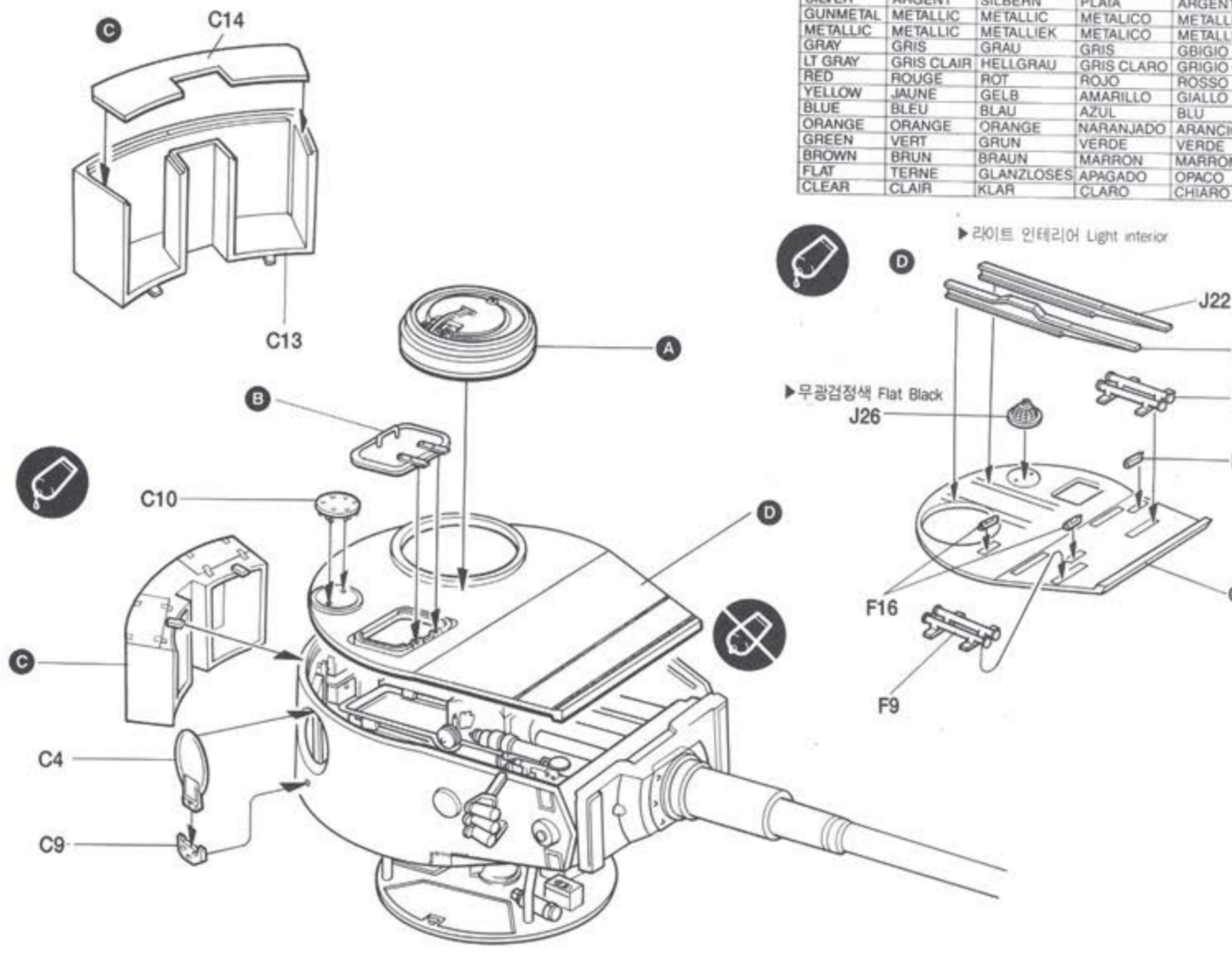

28

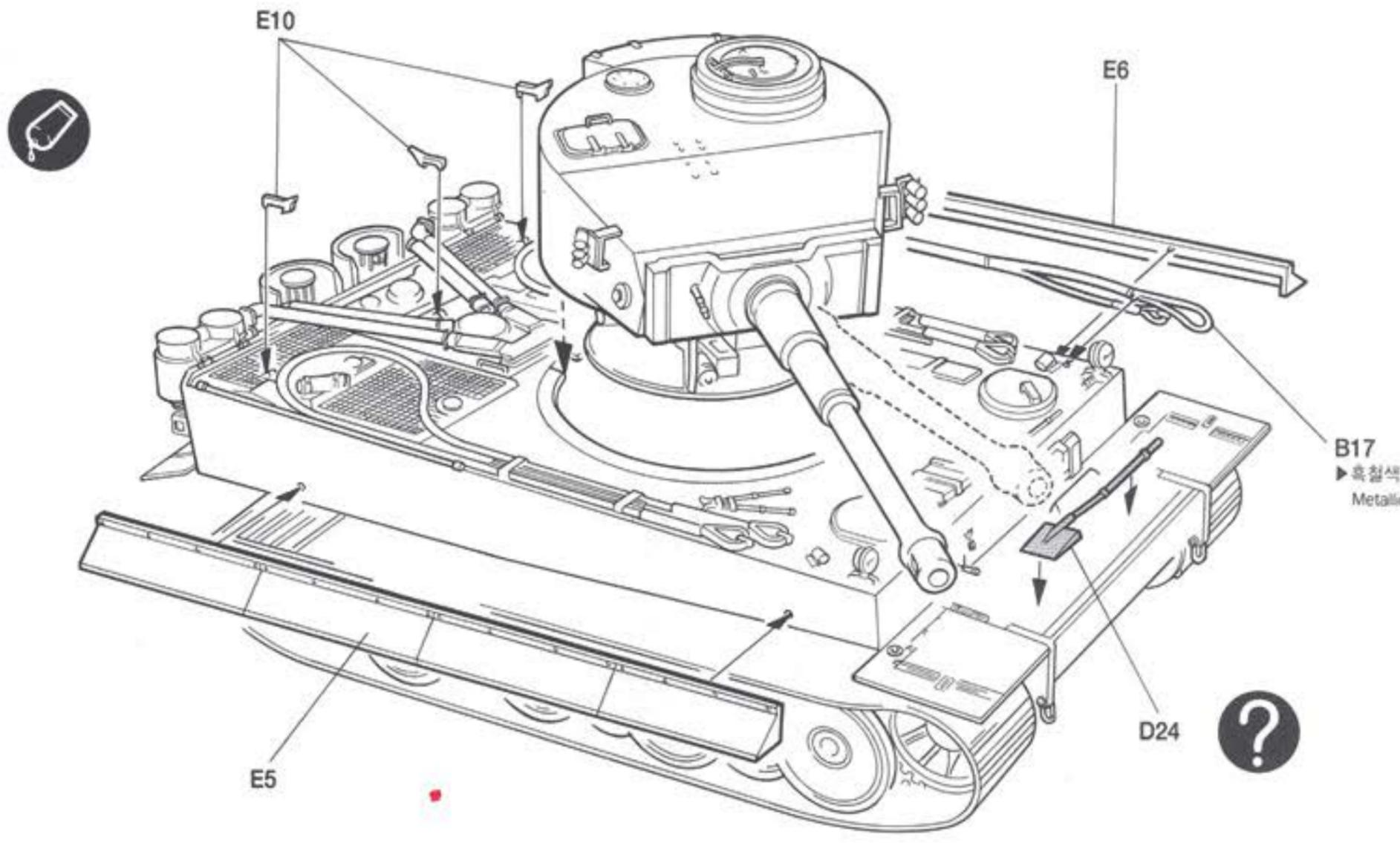

색칠 및 전사지 붙이기 Painting and Decal Placement

* ()는 반대측 번호임
() is opposite number.

A-제2 SS 전차사단 '다스라이히' 1943년 쿠르스크, 러시아
2ND SS PANZER DIVISION 'DAS REICH', KURSK, RUSSIA, 1943

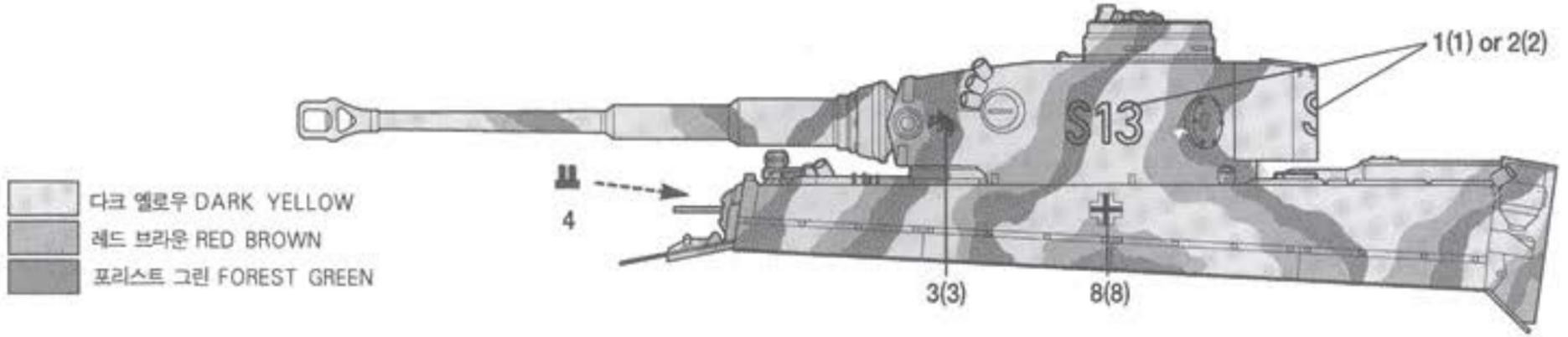

B-제1 SS 전차사단 '라이프스탄다르테 아돌프 히틀러'
1ST SS PANZER DIVISION 'LEIBSTANDARTE ADOLF HITLER'
미하일 비트만 중위 탑승차 1944년 1월 베르디체프, 러시아
COMMANDER LT. MICHAEL WITTMANN, BERDICHEV, RUSSIA, JANUARY 1944

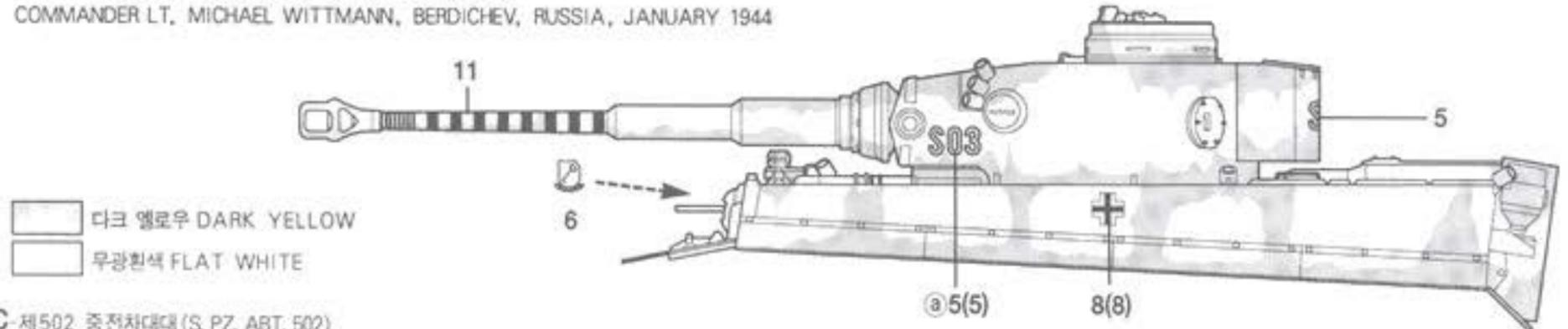

C-제502 중전차대대 (S. PZ. ABT. 502)
502ND HEAVY TANK BATTALION
a) 123호차 (NO. 123): 1942년, 레닌 그라드, 러시아 (LENINGRAD, RUSSIA, 1942)
b) 217호차 (NO. 217): 오토 카리우스 중위 탑승차 1943년 로베츠, 러시아
COMMANDER LT. OTTO CARIUS, LOVETZ, RUSSIA, 1943

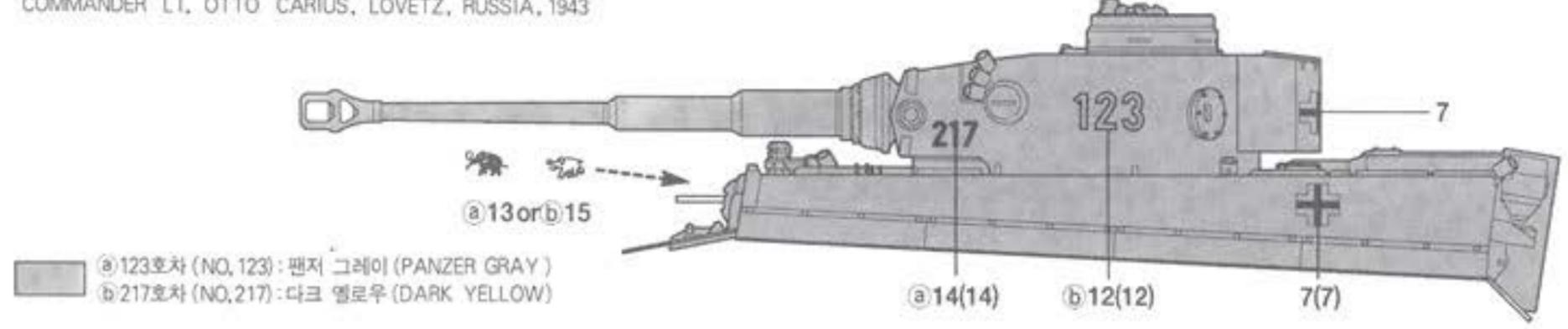

D-제504 중전차대대 (S. PZ. ABT. 504) 1943년 튀니지, 아프리카 군단
504TH HEAVY TANK BATTALION, TUNISIA, AFRIKA KORP, 1943

